

MARINE DIESEL ENGINES

Sole Diesel

OPERATOR'S MANUAL

◦ **SM-82**

◦ **SM-94**

Introduction

Presentation

Dear Customer,

First of all, we would like to thank you for choosing a Solé Diesel product. We recommend that you read this manual carefully before carrying out any of the operations and keep it close at hand, near the engine, as it can be of great use in the future.

Our goal as a manufacturing company is that you enjoy our product, regardless of the use you make of it. The equipment manufactured in Solé Diesel facilities is designed to offer the highest performance in the most demanding operating conditions.

▲ NOTICE

The images, text and information contained in this manual are based on the product's features at the time of publication. Solé Diesel reserves the right to modify this document without prior notice

Abbreviations

BTDC: Before Top Dead Center

ATDC: After Top Dead Center

BBDC: Before Bottom Dead Center

ABDC: After Bottom Dead Center

API: American Petroleum Institute

ACEA: European Automobile Manufacturers' Association

ASTM: American Society for Testing Materials

TBD: To Be Determined

Units of measurement

Measurements are based on the International System of Units (SI), and their converted metric values are indicated in parentheses (). For metric conversion, the following rates are used

- Pressure: $1 \text{ Pa} = 1,0197 \cdot 10^{-5} \text{ kgf/cm}^2 = 1 \cdot 10^{-5} \text{ bar}$
- Torque: $1 \text{ Nm} = 0,10197 \text{ kgf} \cdot \text{m}$
- Force: $1 \text{ N} = 0,10197 \text{ kgf}$
- Power: $1 \text{ W} = 1,341 \cdot 10^{-3} \text{ HP}$

Table of Contents

| | |
|--|----|
| Introduction 2 | |
| Table of Contents | 4 |
| Safety Precautions and Instructions | 6 |
| Engine labels..... | 8 |
| Solé Diesel warranty | 10 |
| Solé diesel limited warranty | 10 |
| Solé Diesel extended warranty | 10 |
| Restrictions | 11 |
| Responsibilities..... | 12 |
| After-sales service contact | 12 |
| Service Assistance | 13 |
| Section 1 - Engine Information | 14 |
| 1.1. Engine Identification..... | 14 |
| 1.2. Engine Parts Identification..... | 15 |
| 1.3. Engine Limited Warranty..... | 16 |
| RESTRICTIONS | 16 |
| Section 2 - Transport, Handling and Storage..... | 17 |
| 2.1. Reception..... | 17 |
| 2.2. Transporting and Handling the Packed Engine | 17 |
| 2.3. Transporting and Handling the Unpacked Engine | 18 |
| 2.4. Storage of Packed and Unpacked Engine..... | 18 |
| Section 3 – Installation | 19 |
| 3.1. Angle of Installation | 19 |
| 3.2. Engine installation | 19 |
| Section 4 – SVT Control Panel..... | 20 |
| 4.1. Identification Panel..... | 20 |
| 4.2. Panel Parts..... | 21 |
| 4.3. Settings..... | 22 |
| TACHOMETER CALIBRATION..... | 22 |
| REPLACING THE LIGHT BULB..... | 22 |
| Section 5 - Operation | 23 |
| 5.1. Prestart Checklist | 23 |
| 5.2. Cranking the Engine..... | 23 |
| 5.3. Stopping Engine..... | 24 |
| 5.4. Engine Operation at Low Temperatures..... | 24 |
| 5.5. Winterzation and Preservation..... | 25 |
| 5.6. Restoration of Operational Conditions | 25 |
| Section 6 - Systems and Scheduled Maintenance | 26 |
| 6.1. Operating Description..... | 26 |
| 6.2. Periodic Maintenance Schedule | 26 |
| 6.3. General..... | 28 |
| MAINTENANCE TASK. SCREW TIGHTENING, FASTENINGT..... | 28 |
| MAINTENANCE TASK. VALVE CLEARANCE INSPECTION | 28 |
| INSPECTION..... | 28 |
| MAINTENANCE TASK. COMPRESSION PRESSURE INSPECTION..... | 29 |
| 6.4. Lubrication System | 30 |
| CIRCUIT DESCRIPTION..... | 30 |
| OIL SPECIFICATIONS..... | 30 |

TABLE OF CONTENTS

| | |
|--|----|
| MAINTENANCE TASK. OIL FILTER CHANGE | 30 |
| MAINTENANCE TASK. OIL LEVEL CHECK | 30 |
| MAINTENANCE TASK. OIL FILL / CHANGE | 31 |
| 6.5. Fuel System | 32 |
| CIRCUIT DESCRIPTION | 32 |
| FUEL SPECIFICATIONS | 32 |
| MAINTENANCE TASK. FUEL LEVEL INSPECTION | 32 |
| MAINTENANCE TASK. FUEL TANK CLEAN | 32 |
| MAINTENANCE TASK. WATER SEPARATOR FILTER PURGUE | 32 |
| MAINTENANCE TASK. FUEL FILTER CHANGE | 33 |
| MAINTENANCE TASK. INJECTION PUMP INSPECTION | 33 |
| MAINTENANCE TASK. INJECTOR INSPECTION | 33 |
| MAINTENANCE TASK. BLEEDING AIR FROM THE FUEL SYSTEM | 34 |
| 6.6. Cooling System | 35 |
| COOLANT CIRCUIT DESCRIPTION | 35 |
| SEAWATER CIRCUIT DESCRIPTION | 35 |
| COOLAN SPECIFICATIONS | 35 |
| MAINTENANCE TASK. COOLANT CHECK | 35 |
| MAINTENANCE TASK. COOLANT FILL / CHANGE | 36 |
| MAINTENANCE TASK. SEAWATER FILTER INSPECTION | 36 |
| MAINTENANCE TASK. SEAWATER PUMP IMPELLER INSPECTION | 36 |
| MAINTENANCE TASK. ZINC ANODE INSPECTION | 37 |
| 6.7. Inlet and Exhaust System | 37 |
| EXHAUST CIRCUIT DESCRIPTION | 37 |
| MAINTENANCE TASK. AIR FILTER INSPECTION | 38 |
| MAINTENANCE TASK. EXHAUST GAS, NOISE AND VIBRATIONS INSPECTION | 38 |
| 6.8. Electrical System | 39 |
| PANEL SVT | 39 |
| BATTERY | 39 |
| CIRCUIT PROTECTION | 39 |
| MAINTENANCE TASK. INCANDESCENT GLOW PLUG INSPECTION | 39 |
| MAINTENANCE TASK. STARTER MOTOR INSPECTION | 40 |
| MAINTENANCE TASK. ALTERNATOR BELT TENSION INSPECTION | 40 |
| MAINTENANCE TASK. BATTERY LEVEL | 40 |
| Section 7 - Troubleshooting | 41 |
| Section 8 – Technical Specifications | 46 |
| Section 9 – Tightening Torques | 48 |
| Section 10 – Wiring Diagrams | 49 |
| Section 11 – Overall Dimensions | 52 |
| Section 12 - Instructions to Replace and Remove | 55 |
| Inspection prior to the delivery of propulsion engines | 56 |
| Maintenance Log | 58 |

Safety Precautions and Instructions

Solé Diesel is concerned for your safety and your machine's condition. Safety Precautions and Instructions are one of the primary ways to call your attention to the potential hazards associated with our engine operation. Follow the precautions listed throughout the manual before and during operation and maintenance procedures for your safety, the safety of others and the performance of your engine.

Types of Safety Precautions:

⚠ WARNING

Indicates the presence of a hazard that can **cause severe personal injuries, death or substantial property damages.**

⚠ CAUTION

Indicates the presence of a hazard that **will or can cause minor personal injuries or property damages.**

⚠ NOTICE

Communicates installation, operation and maintenance information that is safety related but not hazard related.

⚠ WARNING

Servicing the fuel system and combustible materials. A flash fire can cause severe injury or death.



Do not smoke or permit flames or sparks near the fuel injection system, fuel line, fuel filter, fuel pump, or other potential sources of spilled fuels or fuel vapors. Never add fuel to the tank while the engine is running because spilled fuel may ignite on contact with hot parts or from sparks.

Catch fuels in an approved container when removing the fuel line or fuel system. Keep the fuel lines and connections tight and in good condition. Do not replace flexible fuel lines with rigid lines and use flexible sections to avoid fuel line breakage caused by vibrations.

Keep the compartment and the engine clean and free of debris to minimize the risk of fire.

⚠ WARNING



Servicing the air cleaner. A sudden backfire can cause severe injury or death.

Do not operate the engine with the air cleaner/silencer removed.

⚠ WARNING

Combustible materials. A fire can cause severe injury or death.



Engine fuels, fuel vapours and combustible materials are flammable and explosive. Handle these materials carefully to minimize the risk of fire or explosion. Equip the compartment or nearby area with a fully charged fire extinguisher. In case of fire do not open sound shield compartment and follow these instructions:

- Shut down engine(s)
- Continuously discharge entire contents of a halon or CO₂ portable fire extinguisher (or other provision) immediately.

⚠ WARNING

Carbon monoxide (CO) can cause severe nausea, fainting or death.

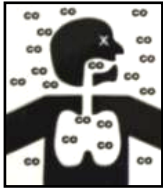

Engine exhaust gases contains carbon monoxide gas. Carbon monoxide is an odourless, colourless, tasteless, no irritating gas that can cause death if inhaled for even a short time.

Get fresh air and do not sit, lie down or fall asleep if anyone shows signs of carbon monoxide poisoning:

- Light-headedness, dizziness
- Physical fatigue, weakness in joints and muscles. Sleepiness, mental fatigue, inability to concentrate or speak clearly, blurred vision. Stomachache, vomiting, nausea.

⚠ WARNING

Keep the area around the battery well ventilated. While the engine is running or the battery is charging, hydrogen gas is produced which can be easily ignited.



Never allow battery fluid (battery contains sulfuric acid) to come in contact with clothing, skin or eyes. Always wear safety gloves and protective clothing when servicing the battery. If battery fluid contacts the eyes and/or skin, immediately flush the affected area with a large amount of clean water and obtain prompt medical treatment.

⚠ CAUTION

Moving parts. Keep hands, feet, hair, clothing and test leads away from the belts and pulleys when the engine is running. Replace guards, screens and covers before operating the engine.

⚠ CAUTION

Before working on the engine or connected equipment, disable the engine as follows:



Set the engine controller (SVT) to OFF Mode.

- (1) Disconnect the power input from battery.
- (2) Disconnect the battery cables. Remove the negative (-) lead first when disconnecting the battery. Reconnect the negative (-) lead last when reconnecting the battery.

Follow these precautions to prevent the starting of the engine by engine controller (SVT), remote start/stop switch, or engine start command from a remote computer.

⚠ CAUTION

Never remove the cooler cap if the engine is hot. Steam and hot engine coolant will spurt out and seriously burn you. Allow the engine to cool down before you attempt to remove the cooler cap.

⚠ NOTICE

Read the engine operator's manual and understand it before operation and maintenance of the engine, to ensure that it continues operating practices and maintenance procedures.

Hearing protection. Use to avoid hearing loss when handling the motor.

⚠ NOTICE

1. The installer / operator of the engine has to wear suitable CLOTHING for the workplace and the situation; in particular, avoid loose clothes, chains, bracelets, rings and all accessories that could become entangled with moving parts.
2. The installer / operator of the engine has to wear personal protective equipment such as gloves, work shoes, eye and hearing protection as required by the task.
3. The area in which the operator is working has to be kept tidy and free of oil and other liquid spillages and solid waste (metal chips, etc.).

Engine labels

⚠ CAUTION - AVISO ⚠

- **Over cranking can cause engine water ingestion.**

Excesivos intentos de arranque pueden provocar entrada de agua en el motor.

If the engine does not turn after several attempts to crank may cause water entering the engine. In this situation it is recommended:

- 1) Close the seacock.
- 2) Drain the water from the exhaust system in the water trap.
- 3) Do not try to restart the engine until the cause of the start fail is identified.

⚠ AVISO ⚠

El motor y/o el inversor se suministran sin ningún fluido en su interior. Consulte el manual para seguir el procedimiento de instalación y puesta en marcha.

The engine and the gearbox are supplied without any fluid inside. Consult the manual to follow the installation procedure and commissioning as well as the fluid capacity - coolant, oil and oil of gearbox -.



Read the engine operator's manual and understand it before operation and maintenance of the engine, to ensure that it continues operating practices and maintenance procedures insurance.



Dangerous voltage. Operate the engine only when all guards and electrical panels are ready.

Hot parts, coolant and steam. Stop the engine and let it cool down before touching or removing any engine part.

Moving parts. Keep hands, feet, hair, clothing and test leads away from the belts and pulleys when the engine is running. Replace guards, screens and covers before operating the engine.

Heavy material. Engine is a heavy element, use the right tools for transportation and handling.

Do not use the motor as a step. Use it as a step can cause engine damage plus cause undesired operation.



Connection point of the battery cables to the engine. Red cable (positive) and black cable (negative).



NOTICE

Tag line installation engine exhaust, above and below the waterline. See 6.7. Intake and exhaust system.

Solé Diesel warranty

Read the manual and documents delivered with each engine before carrying out any of the operations or presenting any queries. The engine is supplied without any liquids. Ensure that the liquids used match the specifications contained in Solé Diesel manuals.

The application of the conditions described in this document shall only be effective for engines or generator sets that have been invoiced after January 1, 2012.

Solé diesel limited warranty

Solé Diesel guarantees that at the time of shipment all its engines and generator sets comply with the provided specifications and do not have any manufacturing defects.

The limited warranty provided by Solé Diesel enters into force from the time of sale to the first end-purchaser or user of the engine or generator set. In the event that the product is not immediately delivered to the end-customer, the warranty shall enter into force 6 months after the date of sale. Any limited warranty period that has not elapsed can be transferred to the following purchaser (s).

Unless authorised otherwise by Solé Diesel, the warranty periods are applied according to the time elapsed in months from the date of purchase or the limit of hours of operation (whichever occurs first) listed in the following table:

| Limited Warranty Coverage Periods | | | | |
|-----------------------------------|----------|-------|--------|-------|
| Product | Pleasure | | Work | |
| | Months | Hours | Months | Hours |
| Propulsion Engines | 24 | 1000 | 12 | 2000 |
| Generator Sets | 24 | 1000 | 12 | 1000 |

Solé Diesel extended warranty

Solé Diesel an extended period of coverage for the following components: engine block, cylinder head, crankshaft, camshaft, flywheel housing, timing gear housing, timing gear, conrod.

| Extended Coverage Periods | | | | |
|---------------------------|----------|-------|--------|-------|
| Product | Pleasure | | Work | |
| | Months | Hours | Months | Hours |
| Propulsion Engines | 36 | 1500 | - | - |
| Generator Sets | 36 | 1000 | - | - |

Restrictions

Coverage:

- a) The warranty covers any failure of the product under normal operating conditions caused by a defect in manufacturing.
- b) The warranty covers the labour costs necessary to replace and/or repair the defective original components, according to Solé Diesel standards of excellence. The time period covered for these operations is limited to 4 hours.
- c) The warranty covers reasonable costs of travel required to carry out the necessary operations. The travel distance is limited to 300 kilometres in conjunction to a travel time of 3 hours.

Excluded from coverage:

- a) If Solé Diesel products are installed and used alongside other products not designed or manufactured by Solé Diesel that affect their operation, the warranty shall apply exclusively to the Solé Diesel products and shall not apply if the products from another manufacturer are inappropriate for use alongside Solé Diesel products or are the cause of the failure or poor operation of our products.
- b) The warranty shall not apply if the revisions and maintenance services indicated in the User and Maintenance Manuals have not been adhered to properly. In case of implemented warranty, supporting document of the revisions and maintenance service should be exhibited, proving the requirements outlined in the manuals have been followed.
- c) Deterioration resulting from time of storage exceeding 6 months and/or storage conditions that do not comply with the procedures described in the User and Maintenance Manuals.
- d) Deterioration resulting from not complying with the procedure for winter storage while the engine is not in service, as described in the User and Maintenance Manuals.
- e) Faults due to negligence, lack of service, accidents, abnormal use and inadequate service or installation.
- f) Faults due to the use of components not manufactured or sold by Solé Diesel.
- g) Faults due to electrical installations that do not comply with Solé Diesel design specifications or are not expressly approved by Solé Diesel.
- h) Faults due to the use of and operation with fuels, oils or lubricants that are not authorised by Solé Diesel.
- i) Faults due to water entering the cylinder(s) through the exhaust system.
- j) Faults in propulsion engines due to the use of a propeller that is inadequate for the load or application. We recommend contacting Solé Diesel to consult the choice of the correct propeller(s).
- k) Failure for general omission of the procedures described in the User and Maintenance Manuals.
- l) Components subjected to normal operating wear and tear.

- m) Costs due to phone communications, loss of time or money, discomfort, launching, grounding, removal or replacement of vessel parts or materials because the design of the vessel makes it necessary to do so to access the engine, and damage and/or accidents caused as a result of a failure.

Responsibilities

Responsibilities of the manufacturer:

The obligations of Solé Diesel are restricted to repairing the defective parts or, IF DEEMED APPROPRIATE BY SOLÉ DIESEL, returning the amount of the purchase or replacing the parts to prevent poor operation resulting from defective materials or faults in the manufacture covered by the warranty.

Solé Diesel reserves the right to modify the design of any of its products without taking on any obligation to modify a product that has been manufactured previously.

This manual, as well as technical documentation, manuals or pamphlets may undergo modifications without prior notice.

Responsibilities of the purchaser:

The purchaser shall be responsible for the care, operation and maintenance of the product in compliance with the contents of the User and Maintenance Manuals. The purchaser shall provide proof of all the maintenance services performed on the product. The costs of said services and that of the components and liquids replaced during said services shall be at the expense of the purchaser.

The maintenance operations described in this manual shall be performed during the Warranty Contract Periods (Limited and Extended Coverage) by an AUTHORISED SOLÉ DIESEL DEALER. Non-compliance with this condition shall void the warranty in all its terms. In such an event, the materials (oil, filters, etc.) and labour involved shall be at the expense of the purchaser. The purchaser should keep the invoice of the work performed as proof.

If the service is not covered by the warranty, the purchaser must pay for all labour performed, the associated materials and any other expense related to the service.

All shipments of products or components sent by the purchaser for inspection and repair shall be paid in advance by the purchaser.

After-sales service contact

Claims shall be presented during the warranty period to the nearest authorised Solé Diesel dealer (see chart of Solé Diesel Dealers), who shall take care the service covered by the warranty.

The purchaser must provide proof of purchase and date of purchase by presenting the authorised dealer with an original copy of the Warranty Registry Card. If this is not available, the purchaser must provide a copy of the purchase invoice of the product in question. Claims under warranty shall not be dealt with by the dealer until the date of purchase has been verified.

The following information must also be provided by the purchaser:

- a) Owner's name, address and contact telephone number.
- b) Product model and serial number.
- c) Number of service hours of the product.

- d) Detailed description of the problem.
- e) Information regarding any repair or installation performed by a service not included in the Solé Diesel distribution network, as well as the services performed.

Service Assistance

For an updated list of our distribution network, visit Dealers section in our web page www.solediesel.com.



Or request this information by contacting Solé Diesel at:

e-mail: info@solediesel.com

Phone: +34 93 775 14 00

Section 1 - Engine Information

1.1. Engine Identification

IDENTIFICATION LABEL:

The nameplate is located above the refrigerator, for SM-82 and SM-94. See example SM-82.

| | | |
|---------------------|--------|---------------------|
| <i>Sole Diesel</i> | | MADE IN SPAIN |
| TIPO TYPE | MINI - | |
| MOTOR N° ENG No. | | |
| kW | R.P.M. | |

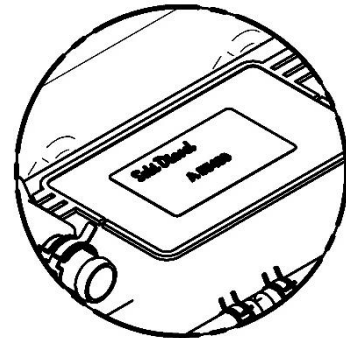
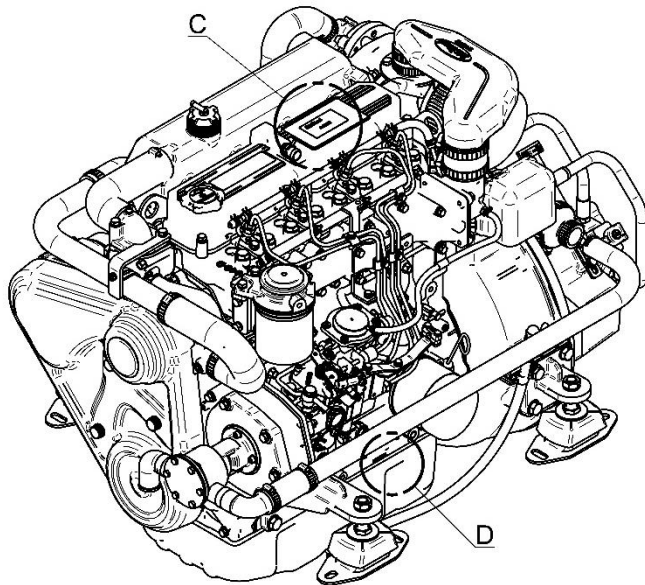

DETAIL C

ENGINE SERIAL NUMBER:

In addition, all engines are marked with the serial number on the block.

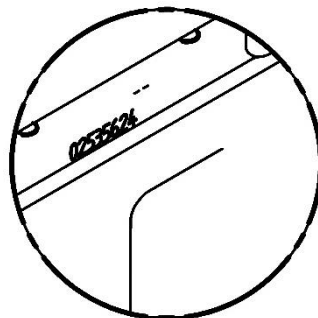

DETAIL D

▲ NOTICE

The standard engine can operate at temperatures between -18°C and $+45^{\circ}\text{C}$.

1.2. Engine Parts Identification

| PIECE | ELEMENT |
|-------|-----------------------|
| 1 | AIR FILTER |
| 2 | GEARBOX CONTROL LEVER |
| 3 | GEARBOX |
| 4 | STARTER |
| 5 | COOLING SYSTEM |
| 6 | COOLING DRAIN PLUG |
| 7 | ALTERNATOR |

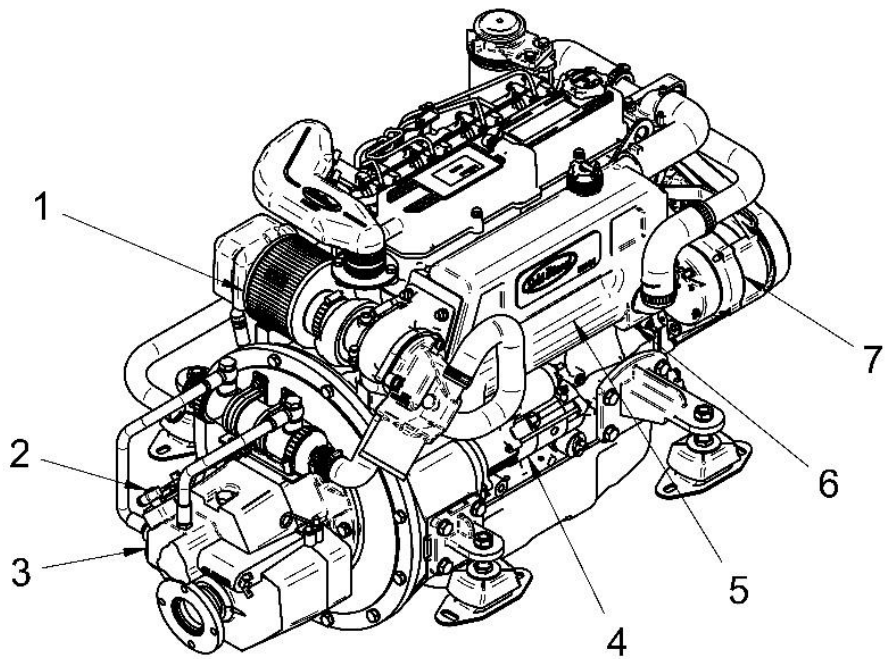

| PIECE | ELEMENT |
|-------|--------------------|
| 8 | COOLANT FILLER CAP |
| 9 | OIL FILLER CAP |
| 10 | SEA WATER PUMP |
| 11 | FUEL FILTER |
| 12 | OIL FILTER |
| 13 | OIL DIPSTICK |
| 14 | OIL DRAIN PLUG |
| 15 | RELAYS COVER |

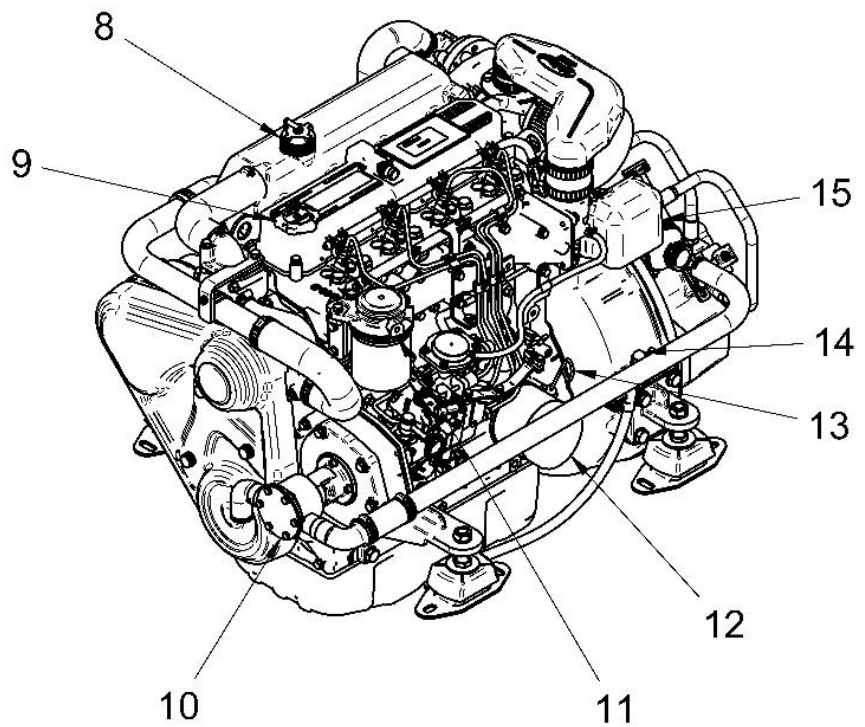

1.3. Engine Limited Warranty

The limited warranty provided by Solé Diesel enters into force from the time of sale to the first end-purchaser or user of the engine. In the event that the product is not immediately delivered to the end-customer, the warranty shall enter into force 6 months after the date of sale. Any limited warranty period that has not elapsed can be transferred to the following purchaser(s).

Unless authorized otherwise by Solé Diesel, the warranty period is applied according to the time elapsed in months from the date of purchase or the limit of hours of operation (whichever occurs first).

| | ENGINE FOR PROFESSIONAL USE | | ENGINE FOR RECREATIONAL USE | |
|--|--------------------------------|-------|--------------------------------|-------|
| | MONTHS | HOURS | MONTHS | HOURS |
| LIMITED WARRANTY COVERAGE PERIODS | 12 | 2000 | 24 | 1000 |
| EXTENDED COVERAGE PERIODS | - | - | 24 | 1000 |

Extended coverage (only recreational engines) is applied to the following components:

- Engine block
- Cylinder head
- Crankshaft
- Camshaft
- Flywheel housing
- Timing gear housing
- Timing gear
- Conrod

RESTRICTIONS

Coverage:

- a) The warranty covers any failure of the product under normal operating conditions caused by a defect in manufacturing.
- b) The warranty covers the labor costs necessary to replace and/or repair the defective original components, according to Solé Diesel standards of excellence. The time period covered for these operations is limited to 4 hours.
- c) The warranty covers reasonable costs of travel required to carry out the necessary operations. The travel distance is limited to 300 kilometers in conjunction with a travel time of 3 hours.

▲ NOTICE

To see EXCLUDING COVERAGE and more information about responsibilities and more, consult the Warranty Manual.

Section 2 - Transport, Handling and Storage

2.1. Reception

When the engine is delivered make sure that the packing has not been damaged during transport and that it has not been tampered with or that components inside the packing have been removed (see information marked on covers, bases and cartons).

Place the packed engine as close as possible to the place of installation and remove the packing material, checking that the goods supplied correspond to the order specifications.

NOTICE

If you notice damage or missing parts, inform SOLÉ S.A. after-sales departments and the carrier immediately and forward photographic evidence of the damage.

After inspecting the goods if you notice damage, write a reservation on the delivery note. Have the carrier countersign the note and advise SOLÉ S.A., preferably by mail (info@solediesel.com).

2.2. Transporting and Handling the Packed Engine

When lifting and transporting the engine use EXCLUSIVELY a forklift or bridge crane of appropriate load capacity, with chains equipped with safety hooks suitable for lifting the load.

The use of any other system automatically invalidates the insurance guarantee against possible damage to the engine.

To unpack the engine, you must follow these steps:

1. Remove the cardboard crate.
2. Lift the engine using a forklift and suitable chains, which hook to the engine eyebolts.
3. Transfer the engine to the intended position of installation.
4. Remove the wooden base.
5. Begin installation operations.



2.3. Transporting and Handling the Unpacked Engine

When the engine is unpacked and ready for transport, use EXCLUSIVELY the appropriate lifting eyebolts.

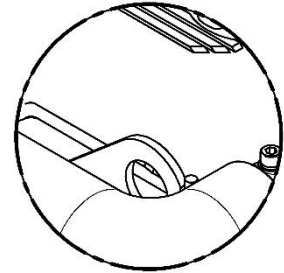
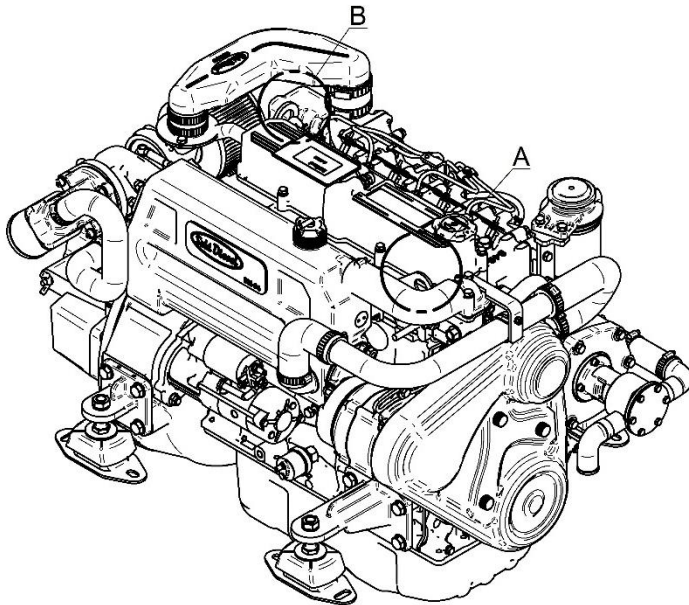

DETAIL A

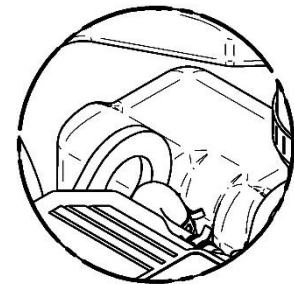

DETAIL B

2.4. Storage of Packed and Unpacked Engine

If the engine is left idle for prolonged periods, the client must check the possible conditions of conservation in relation to the place of storage.

If the engine is unused for prolonged periods and stored, observe all the relative technical specifications.

The treatment of the engine for storage is guaranteed for 6 months after the time of delivery (as specified in Section 1.3 or in the Warranty Manual).

▲ NOTICE

If the user decides to start the engine after a long time period, this must be done in the presence of an authorized technic

Section 3 – Installation

3.1. Angle of Installation

Make sure the engine is installed on a level surface. Otherwise, the following angular operation maximum is permitted:

| | Continuously | Temporary |
|----------------------|--------------|--------------------|
| SM-82 / SM-94 | 15° | 25° (Max. 30 min.) |

If the engine operates in these conditions, check Section 6.5. Lubrication System.

3.2. Engine installation

Follow these steps to install the engine:

1. **FIX ENGINE.** See Section 11 Overall Dimensions and Section 9 Tightening torques.
2. **ENGINE COUPLING.** Couple the motor to the inverter, hydraulic pump, alternator or power extraction mechanism correctly.
3. **CONNECT EXHAUST OUTLET.** See Section 11 Overall Dimensions
 1. **WET EXHAUST OUTLET**
 2. **DRY EXHAUST OUTLET + SEAWATER OUTLET**
4. **CONNECT SIPHON BREAKER.** (if installed) See Section 11 Overall Dimensions
5. **CONNECT SEAWATER INLET.** See Section 11 Overall Dimensions
6. **CONNECT FUEL INLET.** See Section 11 Overall Dimensions
7. **CONNECT LEAK COOLANT OUTLET.** See Section 11 Overall Dimensions
8. **FILL WITH OIL.** See 6.4 Lubrication System.
9. **FILL WITH COOLANT.** See 6.6 Cooling System.
10. **CHECK EACH PIPE CONNECTION** for oil or coolant leaks.
11. **PRIME THE FUEL SYSTEM.** See 6.5 Fuel System
12. **CONNECT TO SVT PANEL.** See Section 11 Overall Dimensions
13. **CONNECT TO BATTERY.** Follow label battery connection into the engine.

▲ NOTICE

It is necessary to install a waterlock (supplied as accessory) in the exhaust system to avoid water ingestion (See section 6.7).





Section 4 – SVT Control Panel

4.1. Identification Panel

The SVT range consists of a control and protection panel set used with propulsion engines. All units are designed for easy operation by both the installer and the end customer, with different degrees of performance, depending on the model.

All panels are identified according to their model in the bottom right section (model SVT 10 is identified on the right).









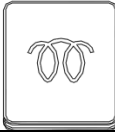

| PANEL | SVT 10 | SVT 20 | SVT 30 | SVT 40 |
|----------------------------------|--|--|---|--|
| |  |  |  |  |
| ELECTRONIC BOARD | | | | |
| Pre-heating pilot light | • | • | • | • |
| Battery alarm | • | • | • | • |
| High temperature alarm | • | • | • | • |
| Low oil pressure alarm | • | • | • | • |
| FIVE POSITIONS KEY SWITCH | | | | |
| Engine stop | • | • | • | • |
| Turn off electronic board | • | • | • | • |
| Turn on electronic board | • | • | • | • |
| Engine pre-heating | • | • | • | • |
| Engine start-up | • | • | • | • |
| INSTRUMENTS | | | | |
| Tachometer / Hourmeter | - | • | • | • |
| Coolant temperature gauge | - | • | • | - |
| Oil pressure gauge | - | - | • | - |
| Voltmeter | - | - | • | - |

NOTICE

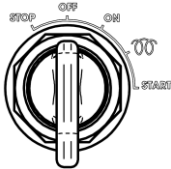
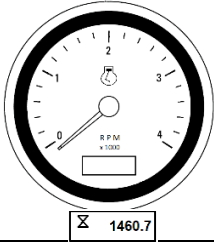
The standard model is SVT 20

4.2. Panel Parts

| PRE-HEATING | | |
|---|--|--|
|  | <p>The LED light turns on when the pre-heating spark plugs receive power. It turns off after a few seconds to indicate that the engine is ready for start-up.</p> <p>NOTE: The only purpose of this LED is to inform the user, it does not act on the engine. The pre-heating spark plugs keep working even if the LED light is not on.</p> | |
| BATTERY CHARGING FAULT | | |
|  | <p>The LED and the buzzer are activated when the alternator is not charging the battery.</p> <p>NOTE: When the engine is off, the alternator is usually not charging and this alarm is on.</p> | |
| HIGH COOLANT TEMPERATURE | | |
|  | <p>The LED and the buzzer turn on when the coolant temperature is too high.</p> <p>NOTE: This alarm should never appear during normal engine operation.</p> | |
| LOW OIL PRESSURE | | |
|  | <p>El led y el zumbador se encienden cuando la presión de aceite es demasiado baja.</p> <p>NOTA: Cuando el motor está apagado es normal que la presión del aceite sea baja y esta alarma esté funcionando.</p> | |
| HIGH SEAWATER TEMPERATURE | | |
|  | <p>This panel part is prepared to install a LED that turns on when the seawater temperature at the exhaust outlet is more than 70°C. In addition, in case of alarm, the buzzer will emit a sound. It is necessary to install the kit alarm temperature exhaust ref. 60900280.</p> <p>NOTE: This box is enabled for all panels except SVT 10</p> | |
| FIVE POSITION KEY SWITCH | | |
|  | <p>The contact key switch is directly connected to the battery (PIN 30) and depending on its position (STOP, OFF, ON, PRE-HEATING, START), the key supplies certain pins/connectors where the different electronic devices are connected.</p> | |
| TACHOMETER AND HOURMETER | | |
|  | <p>The tachometer displays the revolutions of the engine and is adjusted for each engine model. If the panel is to be used for an engine other than Solé Diesel models, the tachometer should be adjusted (see Section 4.3 Settings).</p> <p>The screen located at the bottom of the clock is the work hours counter. The hourglass blinks when its counting the work hours; if it does not blink, it is not counting.</p> | |
| COOLANT TEMPERATURE GAUGE | | |
|  |  | <p>The thermometer indicates the coolant temperature.</p> <p>The pressure meter indicates the pressure of the lubrication circuit.</p> |
| VOLTMETER | | |
|  | <p>The voltmeter indicates the voltage of the engine electrical installation, generated by the alternator.</p> <p>NOTE: During the start-up stage, when the key switch is at the ON and PREHEATING POSITION, the meter displays the battery voltage, as the alternator is not yet working.</p> | |

4.3. Settings

TACHOMETER CALIBRATION

The tachometers supplied with the panel are calibrated in the factory. The user must only calibrate tachometers purchased as spare parts.

The tachometer can be calibrated with the switch at the rear. To know its position, the pulley ratio must be calculated.

$$\text{Pulley ratio} = \frac{\text{Crankshaft pulley diameter}}{\text{Alternator pulley diameter}}$$

After calculating the pulley ratio, refer to the table (approximate value, if required) and rotate the tachometer switch.

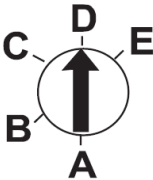
| Alternator Poles Polos del alternador | 12 | Switch Position Posición del interruptor | Switch interruptor |
|--|-------|---|--|
| Pulley Ratio Relación de la polea | 1:01 | A |  |
| | 1.5:1 | B | |
| | 2:01 | C | |
| | 2.5:1 | D | |
| | 3:01 | E | |

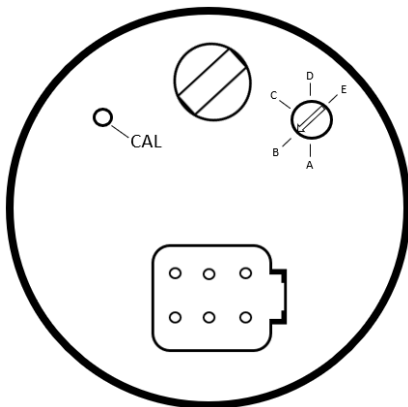
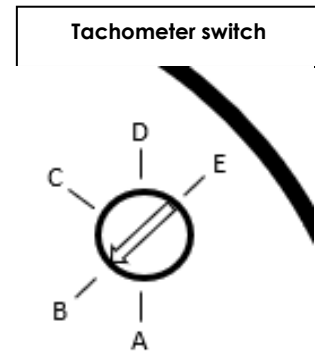

If the pulley ratio is not exactly the same as in the table, the calibration must be completed with the Calibrator (CAL). Introduce a small flat screwdriver into the calibrator (CAL) at the rear of the meter. Carefully calibrate the mechanism moving the meter needle forwards or backwards until it corresponds to the engine speed.

REPLACING THE LIGHT BULB

Unscrew the cap of the light bulb (rear of the meters) and change the light bulb.

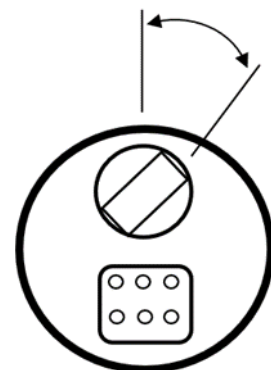

Section 5 - Operation

5.1. Prestart Checklist

Follow these checks and inspections to ensure the correct engine operation. In addition, some checks require verification after unit starts.

AIR CLEANER: Check for a clean and installed air cleaner element to prevent unfiltered air from entering the engine.

AIR INLETS: Check for clean and unobstructed air inlets.

BATTERY: Check for tight battery connections.

COOLANT LEVEL: Check the coolant level according to coolant circuit capacity.

DRIVE BELTS: Check the belt condition and tension of the coolant pump and battery charging alternator belt.

EXHAUST SYSTEM: Check for exhaust leaks and blockages. Check the silencer and piping condition and check for tight exhaust system connections.

Check that the exhaust outlet is unobstructed.

FUEL LEVEL: Check the fuel level and keep the tank(s) full to ensure adequate fuel supply.

OIL LEVEL: Maintain the oil level below dipstick high mark and above dipstick low mark.

OPERATING AREA: Check for obstructions that could block the flow of admission air.

SEAWATER PUMP PRIMING: Prime the seawater pump before initial startup. To prime the pump:

- Close the seacock
- Remove the hose from the seawater-filter outlet
- Fill the hose and seawater pump with clean water
- Reconnect the hose to the water filter outlet
- Open the seacock

Confirm seawater pump operation on startup as indicated by water discharge from the exhaust outlet.

5.2. Cranking the Engine

1. **TURN ON THE KEY POSITION.** To start all instruments with fuel pump.
2. **TURN THE KEY TO PREHEATING POSITION.** To heat the engine for a few seconds before the start.
3. **TURN THE KEY TO STARTER POSITION.** To feed the starter and start the engine.

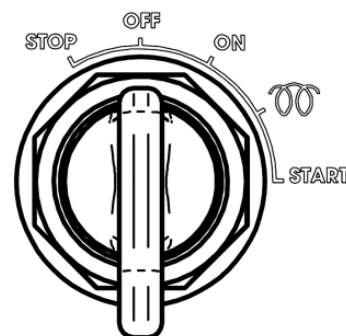

▲ NOTICE

If the engine doesn't start after several attempts to start, may cause water entering in the engine. See warning label on the engine.

After starting up the engine, check the following points. If you find anything wrong, immediately stop the engine, and then investigate the cause.

1. Lubrication oil pressure should be from 0,19 to 0,39 MPa (2 to 4 kgf/cm²) (2 to 4 bar) at nominal speed.
2. Coolant temperature should be 75 to 85°C.
3. Oil temperature should be 60 to 95°C.
4. Check for leakage of oil, coolant and fuel.
5. Knocking should die away as coolant temperature rises. No other defective noise should be heard.
6. Check for exhaust colour and abnormal odours.

5.3. 5.3. Stopping Engine

1. **REMOVE ENGINE LOAD.** Before turning off the engine, it must be freed of all charges (disengaged gearbox to neutral)
2. **TURN THE KEY TO STOP POSITION.** The key automatically returns to the OFF position. All instruments are off.
3. **CLOSE THE SEACOCK.**

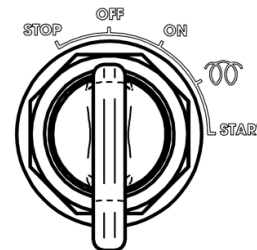

▲ NOTICE

If the needle of tachometer is marking counter rpm when the engine is off, turn the key back to ON and then OFF again.

5.4. Engine Operation at Low Temperatures

Whenever the atmospheric temperature drops below zero, the following series of circumstances occur:

- The cooling liquids may freeze.
- The oil becomes thicker.
- There is a drop in the voltage at the battery terminals.
- The inlet air temperature is low and the engine has difficulty in starting.
- The fuel loses fluidity.

To prevent the damage caused by low temperature operation, the engine should be prepared:

1. Use special low temperature coolant or suitable anti-freezing agent concentration.
2. Close the seawater cock, when the engine is stopped. Open the seawater filter cover and start the engine adding a mixture of freshwater and suitable anti-freezing agent concentration (see package labels) until the seawater circuit is filled completely. Stop the engine and replace the seawater filter cover. Before starting the engine again, open the seawater cock.
Repeat this operation whenever the engine is used at temperatures below 0°C.
3. Use oil with suitable quality and viscosity. SAE 15W40 is recommended. Under extreme conditions contact with technical support.
4. Cover battery with an adequate material to protect it against the cold. Check that the battery is fully charged.
It is also advisable to use a dielectric spray on the electrical connections.
5. When starting the engine, make sure that the glow plugs become hot enough.
6. If necessary, replace the diesel oil by a specified diesel oil type for low temperatures. The accumulation of impurities in the fuel tank could cause faulty firing.

▲ NOTICE

All engines not in use are subject to rusting and corrosion of machined surfaces that are not protected with a paint coating. The degree of corrosion depends on meteorological changes and climatic conditions. The following recommendations are therefore of a general nature but they will help prevent or reduce the risk of damage due to rusting.

5.5. Winterization and Preservation

If the boat is not going to be used for a long period of time or during the winter, certain tasks must be carried out to keep it in perfect operating condition. Follow the steps indicated below carefully:

1. Clean the outer surface of the engine.
2. Bleed the seawater circuit by filling it with fresh water. Fill the seawater circuit again with a mixture of fresh water and anti-freezing agent.
3. Remove the impeller from the seawater pump, clean it with fresh water and store it in place protected from moisture and sunlight.
4. Renew and refill the heat exchanger to the maximum level with a mixture of fresh water and anti-freezing agent.
5. Renew the oil in the engine.
6. Cover the air intake.
7. If the fuel tank is small, empty it completely and clean it; fill it up again with a mixture of diesel and anti-corrosion additive. Solé S.A. recommends DIECYL PLUS. Add one measure of this additive for every 25 liters of diesel. On the other hand, if the fuel tank is large, add 1 liter of this additive for every 500 liters of diesel.
8. Clean and dry the area where the engine is installed.
9. Loosen the belts.
10. Apply dielectric spray on the electrical connection, disassemble the battery and charge it several times during the time it is not being used.
11. Apply moisture repellent spray on the motor.

5.6. Restoration of Operational Conditions

When starting up the engine again after winter lay-up, certain operations must be performed. Follow these steps:

1. Fill the fuel tank with clean diesel. The mixture of diesel oil and anti-corrosion additive in tank for winter lay-up can be used to operate the engine.
2. Check the fuel filter. If the filter is clogged, replace the filter.
3. Renew the oil in the engine.
4. Check the condition of coolant circuit's rubber hoses.
5. Reconnect the battery and apply a layer of neutral Vaseline to the battery terminals.
6. Remove the nozzle supports and clean them. If possible, verify the setting of the nozzles at a workshop. Then install the clean nozzles.
7. Connect the cooling and exhaust system. Open the seawater cock.
8. Verify whether there are any leaks in the fuel, coolant and oil systems.

Section 6 - Systems and Scheduled Maintenance

6.1. Operating Description

Information of special tools required and basic safety precautions.

Disassembly:

- ✓ Use the correct tools and instruments. Serious injury or damage to the engine can result from using the wrong tools and instruments.
- ✓ Use an overhaul stand or work bench if necessary. Also, use assembly bins to keep the engine parts in order of removal.
- ✓ Lay down disassembled or cleaned parts in the order in which they were removed. This will save you time at reassembly.
- ✓ Pay attention to the marks on assemblies, components and parts for positions or directions. Put on your own marks, if necessary, to aid reassembly.
- ✓ Carefully check each part for faults during removal or cleaning. Signs of abnormal wear will tell if parts or assemblies are functioning improperly.
- ✓ When lifting or carrying heavy parts, get someone to help you if the part is too awkward for one person to handle. Use jacks and chain blocks when necessary.

Reassembly:

- ✓ Wash all engine parts, except oil seals, O-rings, rubber seals, etc. in cleaning solvent and dry them.
- ✓ Use only the correct tools and instruments.
- ✓ Use only good quality lubricating oils and greases. Be sure to apply a coat of oil, grease, or sealant to parts as specified.
- ✓ Use a torque wrench to tighten parts when specified tightening torques is required.
- ✓ Replace all gaskets and packing. Apply appropriate amount of adhesive or liquid gasket when required.

▲ NOTICE

- ✓ Increase the frequency of maintenance in harsh duty conditions (frequent stops and starts, dusty surrounding, prolonged winter season, no-load running).
- ✓ Risk of burns during maintenance operations carried out when the engine is hot. Wear suitable safety clothing.
- ✓ It is strictly forbidden to clean the engine with compressed air.
- ✓ It is strictly forbidden to perform maintenance/cleaning operations in the presence of moving parts.
- ✓ Use gloves, overalls, etc. to protect the body from burns.

6.2. Periodic Maintenance Schedule

The maintenance and fault diagnostic procedures involve risks that may cause severe injury or even death. These procedures should therefore be carried out solely by qualified electrical and mechanical specialists. Before any maintenance and cleaning work, make sure that there are no moving parts, that the generator housing has cooled to ambient temperature, that the electricity generating set cannot be accidentally started up and that all procedures are strictly observed.

SYSTEMS AND SCHEDULED MAINTENANCE

| | Inspection Item | Intervals | | | | | | | Winter storage and Preservation |
|---------------------|---|-----------|-------------|------------|------------|------------|------------|---------------|---------------------------------|
| | | Daily | 1st 20h-50h | Every 200h | Every 400h | Every 800h | Every year | Every 2 years | |
| General | Screw tightening, fastening. | | I | | I | | | | |
| | Engine block. | | | | | | | | L |
| | Valve clearance. | | | | I | | | | |
| | Exhaust gas, noise and vibrations. | I | | | | | | | |
| | Compression pressure. | | | | | I | | | |
| Lubrication system* | Engine oil. | I | C | C | | | C | | C |
| | Oil filter. | | C | C | | | | | |
| Fuel system | Fuel level. | I | | | | | | | |
| | Fuel tank. | | | | | | L | | V/L/I |
| | Fuel filter. | | | | C | | | | |
| | Water separator filter (if applicable). | | V | | C | | | | |
| | Injection pump. | | | | | I | | | |
| Intake system | Injector. | | | | | I | | | |
| | Air filter. | | I | | C | | | C | I |
| Cooling system | Coolant. | I | | | | | | C | C |
| | Salt water circuit. | | | | | | | | I/L |
| | Anode | | | I/C | | | | | |
| | Water filter. | I | L | L | | | | | |
| | Sea water cock. | I | | | | | | | |
| | Salt water pump impeller. | | | I/C | I | | | | I/L |
| Electrical system | Incandescent glow plug. | | | | I | | | | |
| | Starter motor and alternator 12/24V. | | | | I | | | | |
| | Alternator 12/24V belt and tension. | | I | | I | C | | | I |
| | Battery level. | | I | I | | C | | | |

* Use oil with 15W40 viscosity and no less than ACEA E5 or API CH-4/SJ quality.

I: Inspect, adjust or fill. E: Empty. C: Change. CL: Clean.

6.3. General

Solé Diesel offers, for these engine models, a maintenance kit:



| | |
|----------------|----------|
| Ref. kit SM-82 | 17840110 |
| Ref. kit SM-94 | 17940110 |

MAINTENANCE TASK. SCREW TIGHTENING, FASTENING

For details of tightening torques see Section 9 Torques.

MAINTENANCE TASK. VALVE CLEARANCE INSPECTION

The rocker cover must be dismantled to check the valve clearance. This operation must be carried out when the engine is cold.

| Ítem | Assembly standard |
|--|-------------------|
| Valve clearance (cold setting) Inlet exhaust | 0,25 mm |

INSPECTION

1. Inspect the valve clearance in the injection sequence. To check, turn the crankshaft by the specified crank angle in the normal direction to bring the piston to the top dead center of the compression stroke.

| Injection sequence | Crank angle |
|------------------------------------|-------------|
| SM-82 / SM-94 1 – 3 – 4 – 2 | 180° / 240° |

2. The TDC of the compression stroke can be obtained by aligning the TDC mark on the crankshaft pulley with the mark on the gear case.
3. First align the TDC mark for the No.1 cylinder. Confirm that the valves do not move up and down when the crankshaft is turned about 20° in normal direction of rotation and in reverse direction. If the rocker arms move, No. 1 piston is at TDC on the intake or exhaust stroke. In such a case, turn the crankshaft 360° in the direction of engine rotation again. No.1 piston is now at TDC on the compression stroke.

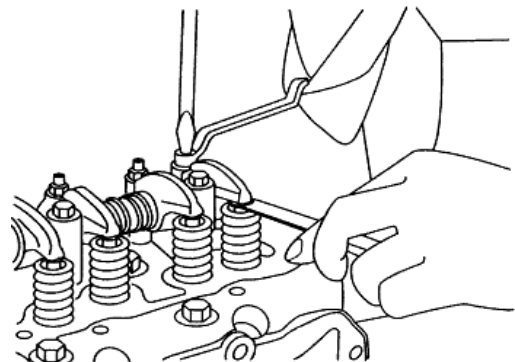

4. Loosen the lock nut for the adjusting screw. With a feeler gauge inserted between the rocker arm and valve cap, adjust the valve clearance by turning the adjusting screw.
5. After adjusting the clearance, tighten the lock nut. Inspect the clearance again and make sure that it is correct.

6. Turn the crankshaft 240° or 180° clockwise, according to your engine model (see table 8. Injection sequence), from TDC of the No.1 cylinder, to set the No.2 cylinder TDC. Repeat from step 1 to step 6. And the same procedure for No.3 and 4 cylinders.
7. After the valve clearance on the valves for all cylinders has been adjusted, turn the crankshaft two or three times and make sure the valve clearance is correct.

▲ NOTICE

Valve clearance should be inspected and adjusted when the engine is cold.

ADJUSTING

1. Loosen the lock nut of the adjusting screw. Adjust the clearance by turning the screw in either direction to the extent that the gauge is slightly gripped between the rocker arm and valve cap.
2. After adjusting the clearance, tighten the lock nut. Inspect the clearance again and make sure that it is correct.

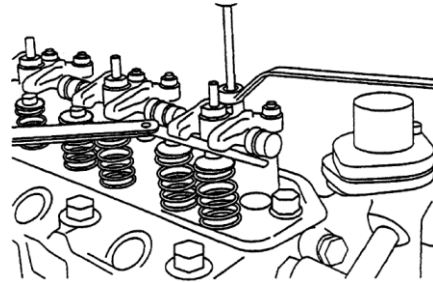

MAINTENANCE TASK. COMPRESSION PRESSURE INSPECTION

Start by:

1. Make sure the engine oil level, air cleaner, starting motor and battery are well-conditioned.
2. Start the engine and allow it to warm up thoroughly, until 50°C or more coolant temperature.

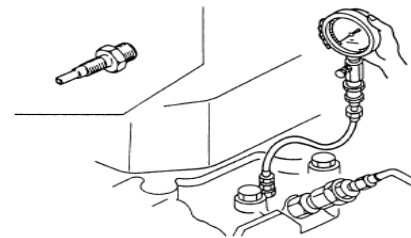

Measure the compression pressure on all cylinders:

1. Remove the injection nozzle from the cylinder head where the compression pressure is to be measured.
2. Attach the compression pressure gauge.
3. Disconnect the stop solenoid connector (the fuel supply shut off) and crank the engine by means of the starter, and read the compression pressure gauge indication when the engine is running at specified speed.
4. If the compression pressure is lower than repair limit, check the engine parts affected.

| | Engine speed | Compression pressure | Repair limit | Máximum pressure difference between cylinders |
|---------------|--------------|--------------------------------------|--------------------------------------|---|
| SM-84 / SM-92 | 300 rpm | 2,9 MPa (30 kgf/cm ²) | 2,6 MPa (27 kgf/cm ²) | 0,25 MPa (2,5 kgf/cm ²) |

▲ NOTICE

- It is not a good practice to measure the compression pressure on only few cylinders, and presume the compression on the remaining cylinders.
- Compression pressure varies with engine speed. Check engine speed when measuring the compression pressure.
- The compression pressure will be slightly higher in a new or overhauled engine due to new piston rings, valve seats, etc

6.4. Lubrication System

CIRCUIT DESCRIPTION

The lubrication circuit is forced by the trochoid gear pump, and it is composed of the following elements.

| PIECE | ELEMENT |
|-------|-----------------------|
| 1 | MAIN GALLERY |
| 2 | OIL PUMP |
| 3 | OIL STRAINER |
| 4 | OIL PAN |
| 5 | OIL FILTER |
| 6 | PRESSURE RELIEF VALVE |

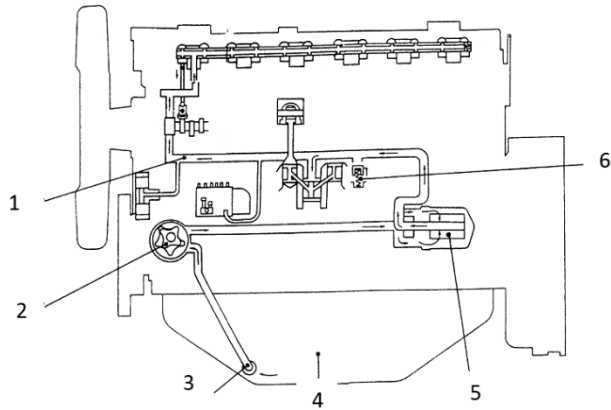

| | Oil circuit capacity (l) |
|-------|--------------------------|
| SM-82 | 10 |
| SM-94 | 10 |

OIL SPECIFICATIONS

Use oil with 15W40 viscosity (this is an all-season oil for temperatures ranging between -15°C and +40°C) or select the most suitable oil viscosity for the atmospheric temperatures on which the engine is going to be operated. On the other hand, use oil quality no less than ACEA E5/E3 or API CH-4/SJ. Other engine oils may affect warranty coverage, cause internal engine components to seize and/or shorten engine life.

Never mix different types of engine oil. This may adversely affect the lubricating properties of the engine oil.



MAINTENANCE TASK. OIL FILTER CHANGE

The oil filter is located under inlet manifold of the engine. Remove oil filter with a belt wrench. When fitting a fresh oil filter, smear a small quantity of oil into the annular seal and firmly tighten it with the hand. When this operation is finished, start the engine and check oil is not leaking.



MAINTENANCE TASK. OIL LEVEL CHECK

Check the oil level in the crankcase daily or before each start-up to ensure that the level is between the upper (Max mark) and lower (Min mark) lines on the dipstick. To check the oil level:

1. Remove the dipstick
2. Wipe the dipstick end
3. Reinsert inside the guide
4. Remove it again to see the oil level

If the engine is fitted inclined, the oil dipstick must be modified to avoid problems of aspiration by the oil pump. See the table enclosed for modification level in dipstick. Increase High level (H) to D on original oil dipstick.

| ENGINE INCLINATION | DIMENSION D | |
|--------------------|-------------|---------|
| | SM-82 | SM-94 |
| 4° | 12.5 mm | 12.5 mm |
| 8° | 35 mm | 35 mm |
| 12° | 50 mm | 50 mm |
| 13.5° | 57 mm | 57 mm |

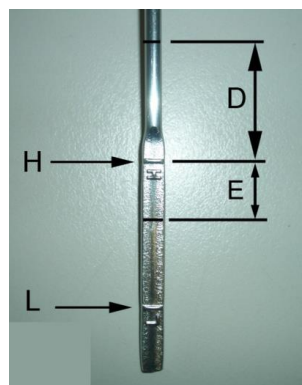
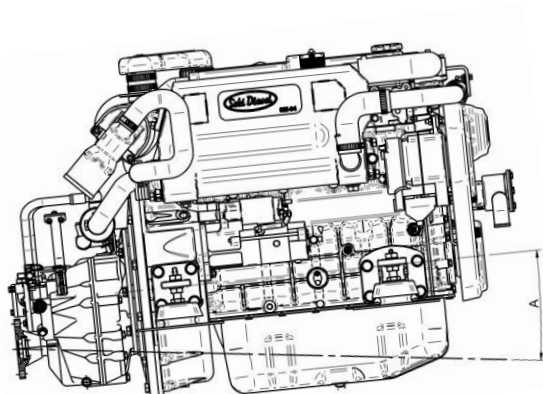

NOTICE

Do not operate the engine if the oil level is below the Min mark or above the Max mark. Be careful the oil dipstick marks refer to the engine as a horizontal position. Therefore, check the engine inclination when the oil level is verified.

MAINTENANCE TASK. OIL FILL / CHANGE

Oil must be changed with hot engine so as to be sure the oil is fully drained. The procedure is the following:

1. Drain the oil (follow steps below)
 - a. Stop the engine.
 - b. Disconnect the battery negative (-) terminal.
 - c. Remove the oil drain plug.
 - d. Connect the external oil pump to the end of the oil drain hose. Place the outlet of the pump into an oil collection container.
 - e. Allow time for the engine oil to drain completely.
2. Replace the oil filter.
3. **Remove dipstick**
4. Fill with oil according to oil capacity circuit.
5. Check for leaks.
6. Check oil level according to the oil level check procedure.

NOTICE

Never overfill. Overfilling may result in white exhaust smoke, engine overspeed or internal damage.

6.5. Fuel System

CIRCUIT DESCRIPTION

The fuel system is based on a fuel feed pump and an in-line mechanical injection pump.

| PIECE | ELEMENT |
|-------|-----------------------------------|
| 1 | Fuel injection Nozzle |
| 2 | Fuel injection pipe |
| 3 | Leak-off pipe |
| 4 | Injection pump |
| 5 | Feed pump |
| 6 | Fuel filter |
| 7 | Tank (supplied as accessory) |
| 8 | Fuel decanting filter (accessory) |
| 9 | Fuel intake pipe (accessory) |

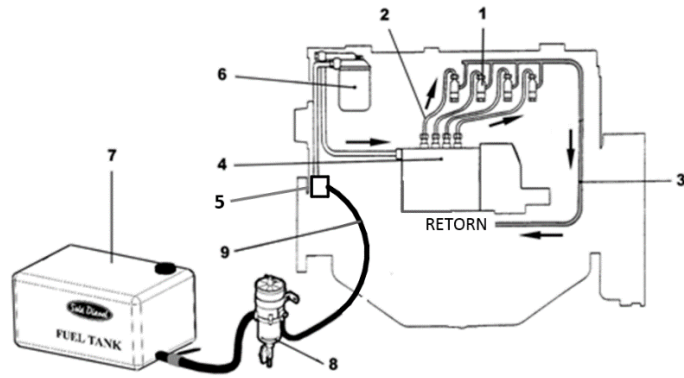

FUEL SPECIFICATIONS

Use ASTM diesel fuel No.2-D for the best engine performance, to prevent engine damage. Never use kerosene, heavy diesel fuel or biodiesel. It is essential to use clean and filtered diesel oil.

The use of diesel oil that not complies with the technical specifications may affect warranty coverage and cause serious damage in the injection system and internal engine components.

MAINTENANCE TASK. FUEL LEVEL INSPECTION

Periodically, it is necessary to check the fuel level to assure the operation of the engine. On top of that, if fuel pump sucks air when the fuel level is lower than pump suction, it could break.

Whenever possible, keep the fuel tank full. The temperature changes may cause condensation of the damp air present in the tank and this water accumulates at the bottom. It can cause an increase of corrosion or an impossibility of starting the engine if this water is aspirated by the fuel pump.

MAINTENANCE TASK. FUEL TANK CLEAN

The fuel impurities could obstruct the suction pump. For this reason, drain out the content of the fuel tank to remove condensate and any foreign material. Then, wash the tank with fuel and refill it.

MAINTENANCE TASK. WATER SEPARATOR FILTER PURGUE

The fuel system has to have a water separator filter (supplied as accessory) to avoid the inlet of water in the fuel circuit. According to the maintenance plan it is necessary to purge the filter to eliminate water periodically. This is the procedure:

1. Loosen the bottom nut to eliminate water.
2. Shut it off again.
3. Check for any leakage.



MAINTENANCE TASK. FUEL FILTER CHANGE

Procedure to change the fuel filter:

1. Remove fuel filter with a belt wrench.
2. Place a new fuel filter and firmly tighten it with the hand.
3. Prime the system.
4. When this operation is finished, start the engine and check that it is not leaking.

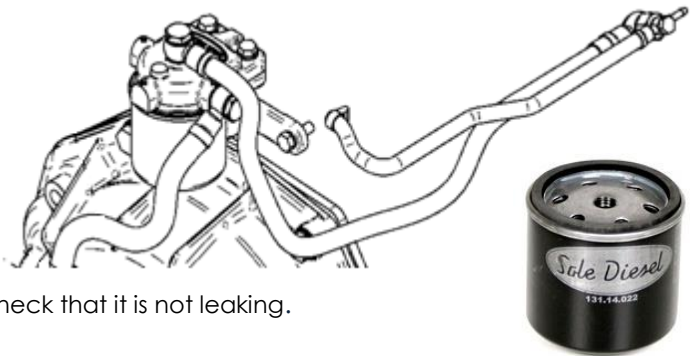

CAUTION

Wash hands after any contact with diesel fuel.

MAINTENANCE TASK. INJECTION PUMP INSPECTION

The injection pump is adjusted at factory and should never be adjusted carelessly. Such adjustment, whenever is required, shall be made by a SOLÉ DIESEL licensed service shop, since a precision pump monitor and skill knowledge are required.

You must check:

- The presence of exhaust smoke color.
Procedure: quickly accelerate engine.
Criteria: no remarkably black smoke exhaust, and correct function of fuel cut-off solenoid
- Any leaks at the body injection pump or fuel lines

MAINTENANCE TASK. INJECTOR INSPECTION

To check the injection pressure of injectors (opening pressure) you have to follow these steps:

1. Remove nozzle and washer.
2. Install the injection nozzle on the tester. Slowly operate the tester handle full strokes to bleed (remove) air from the pipe and nozzle.
3. Make a slow increase in pressure by operating the tester handle at a speed of more than one stroke per second while observing the pressure gauge.
4. The pressure gauge reading will slowly increase and, when the nozzle starts discharging fuel, it will go down fast. Take the gauge reading right then as the injection pressure.

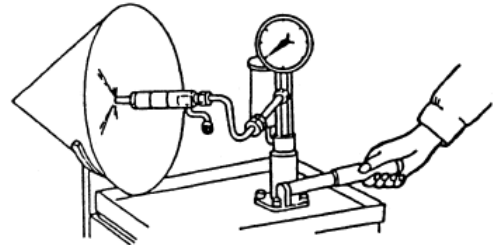
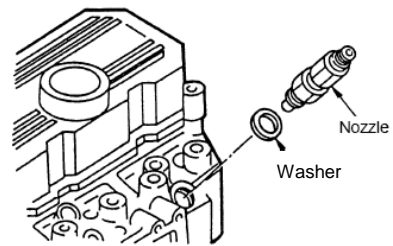

Injection pressure 17,65 MPa (180 kgf/cm²)

5. To adjust the injection pressure, increase or decrease the amount of shims fitted to the nozzle holder.

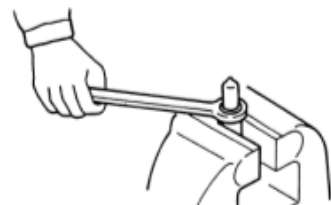

- Look at the orifice discharge pattern (shape of discharge) when fluid begins to flow through the injection nozzle. The discharge must be finely and uniformly atomized. Any change is an indication of a bad nozzle.

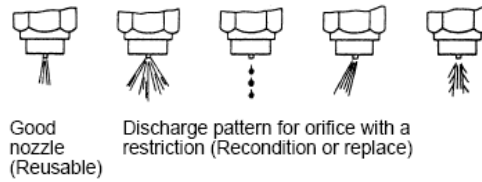

- If the nozzle is bad, remove the tip from the nozzle and wash needle valve and body in clean washing solution. And if the nozzle is still bad after the tip has been washed, replace the tip.
- When installing the new tip, remove synthetic resin film from the tip and slide the needle valve in the body in clean diesel fuel to wash off inhibitor completely
- The washer shown on figure must be replaced.

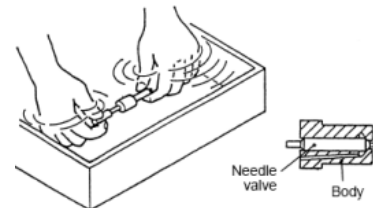

WARNING

When testing the injection nozzle, keep its tip pointed away from the operator. Fuel from the orifices in the tip of the nozzle is under high pressure and can cause injury to the operator.

MAINTENANCE TASK. BLEEDING AIR FROM THE FUEL SYSTEM

Prime the fuel system to bleed the air from the circuit. Trapped air in the fuel system can cause difficult starting and erratic engine operation. It is necessary to prime the system:

- ✓ Before starting the engine for the first time.
- ✓ After running out of fuel and adding fuel to the tank.
- ✓ After fuel system maintenance such as changing the fuel filter, draining the fuel/water separator, or replacing a fuel system component.

For this operation you have to follow these steps:

- Loosen all the injection pipes.
- Start the engine to drive out air in the injection pipes and nozzles automatically.
- When fuel overflows from an injection pipe, tighten it up and wait until fuel overflows from another one. Repeat it until all injection pipes are tightened.
- After bleeding, clean up fuel spillage.

CAUTION

When fuel overflows from the injection pipes, wipe thoroughly with a cloth. Spilled fuel is a fire hazard.

6.6. Cooling System

The engine cooling system is based on coolant circulation controlled by centrifugal pump with thermostatic control and heat exchanger, where the coolant is refrigerated by sea water. Moreover, the exhaust manifold is cooled also by sea water.

COOLANT CIRCUIT DESCRIPTION

| PIECE | ELEMENT |
|-------|----------------|
| 1 | Coolant pump |
| 2 | Heat exchanger |
| 3 | Thermostat |

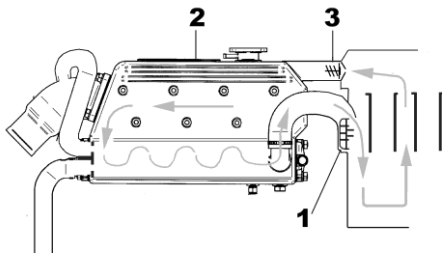

| | Coolant circuit capacity (L) |
|-------|------------------------------|
| SM-82 | 11 |
| SM-94 | 11 |

SEAWATER CIRCUIT DESCRIPTION

| PIECE | ELEMENT |
|-------|-------------------------------------|
| 1 | Bottom cock (supplied as accessory) |
| 2 | Sea water filter |
| 3 | Sea water pump |
| 4 | Heat exchanger |
| 5 | Wet exhaust elbow |

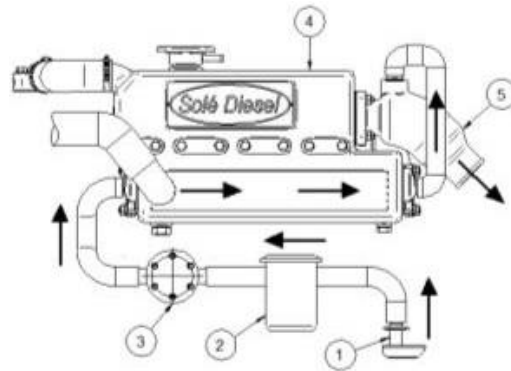

COOLANT SPECIFICATIONS

It is recommended use KRAFFT ACU 2300 CC 50% coolant or another coolant with similar specifications. On the other hand, distilled water with an anti-freezing agent is also suitable. The anti-freezing agent concentration according to operating conditions is specified in anti-freezing agent package labels. It is advisable select the anti-freezing agent concentration based on a temperature approx. 5°C under the actual atmospheric temperature.

Other engine coolants may affect warranty coverage, cause an internal build-up of rust and scale and/or shorten engine life.

▲ NOTICE

Never mix different types of coolants. This may adversely affect the properties of the engine coolant.

MAINTENANCE TASK. COOLANT CHECK

Allow the engine to cool. Release pressure from the cooling system before removing the pressure cap. To release pressure, cover the pressure cap with a thick cloth and then slowly turn the cap counterclockwise. Remove the cap after pressure has been completely released and the engine has cooled. Check the coolant level at the tank, the level must be approximately 3/4 full.

MAINTENANCE TASK. COOLANT FILL / CHANGE

1. Drain off all the coolant by opening the two drain plugs, one in the heat exchanger and the other in the cylinder block.
2. Close the drain plugs.
3. Remove bleeding bolt of thermostat holder
4. Refill to the hole in the tank cap with coolant

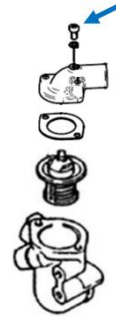
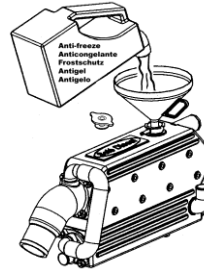
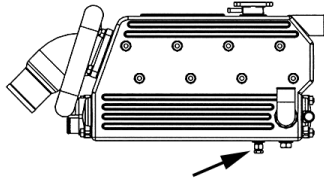
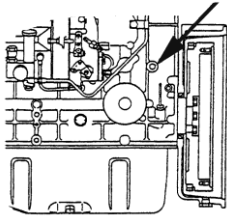

MAINTENANCE TASK. SEAWATER FILTER INSPECTION

It is important to install a seawater filter (supplied as accessory) between seawater cock and the seawater pump to avoid that any impurity might clog the seawater circuit or seawater pump.

To clean this filter:

1. Loosen the wing nut.
2. Remove the filtering component.
3. Clean it.
4. Fit it again taking care that the cover is well seated on the o-ring.
5. Start the engine to check seawater leakages.

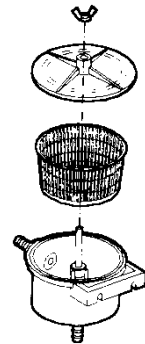

MAINTENANCE TASK. SEAWATER PUMP IMPELLER INSPECTION

Seawater pump impeller is neoprene and cannot rotate dried. If operated without water, the impeller can be broken. It is important therefore that a spare impeller is always available. Impeller inspection and replacement procedure:

1. Close the seawater cock.
2. Remove the seawater pump cover plate.
3. Remove the impeller from the shaft.
4. Clean the housing.
5. Inspect the impeller for damaged, cranked, broken, missing or flattened vanes. The impeller vanes should be straight and flexible. If it is damaged replace with a new one.
6. Lubricate the impeller with soapy water before installation.
7. Install the impeller. During installation push and rotate the impeller in the same direction as the engine rotation until it is thoroughly seated in the impeller housing.
8. Inspect the cover plate and gasket for corrosion and/or damage. Replace components as necessary.
9. Lubricate the gasket with silicon grease and attach the gasket and cover plate to the seawater pump housing.
10. Open the seacock.
11. Start the engine and check for leaks.

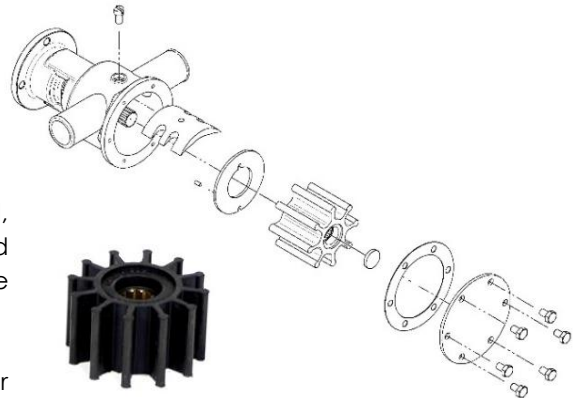

MAINTENANCE TASK. ZINC ANODE INSPECTION

In order to avoid the corrosion produced by galvanic currents, the engine is fitted with a zinc anode located on the front lid of the coolant-seawater heat exchanger. Anticorrosion zinc anode inspection and replacement:

1. With the engine cooled, close the seacock, open the coolant drain plug and drain the coolant into a suitable container.
2. Remove the anticorrosion zinc anode (plug) from the heat exchanger.
3. Use a wire brush to remove the loose corrosion on the anticorrosion zinc anode.
4. Clean the threaded hole of the heat exchanger and coat the threads of anticorrosion zinc anode. Install the anticorrosion zinc anode into the heat exchanger.
5. Close the coolant drain plug and open the seacock. Refill the coolant circuit.
6. Start the engine and check for leaks at the anticorrosion zinc anode location. The pump is operating if the seawater flows from the exhaust outlet.

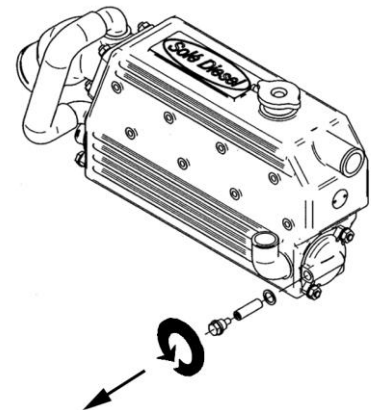

6.7. Inlet and Exhaust System

EXHAUST CIRCUIT DESCRIPTION

There are two possible installations of the exhaust system. You need to check the distance between water injection point and waterline to decide which type of installation you need. This information is specified in the following drawings.

The elements included in the drawing are essential for the correct engine operation:

- Waterlock (supplied as accessory) to prevent seawater from entering inside the engine when it stops.
- | | |
|----------------------|-----|
| Minimum Capacity (l) | 3,5 |
|----------------------|-----|
- Goose neck (supplied as accessory)
 - Siphon breaker (supplied as accessory) – needed in case there is less than 150 mm between the water injection point of wet exhaust and the waterline, or if the point of injection is below waterline.

Type 1 installation. When between water injection point of wet exhaust and waterline is minimum 150 mm.

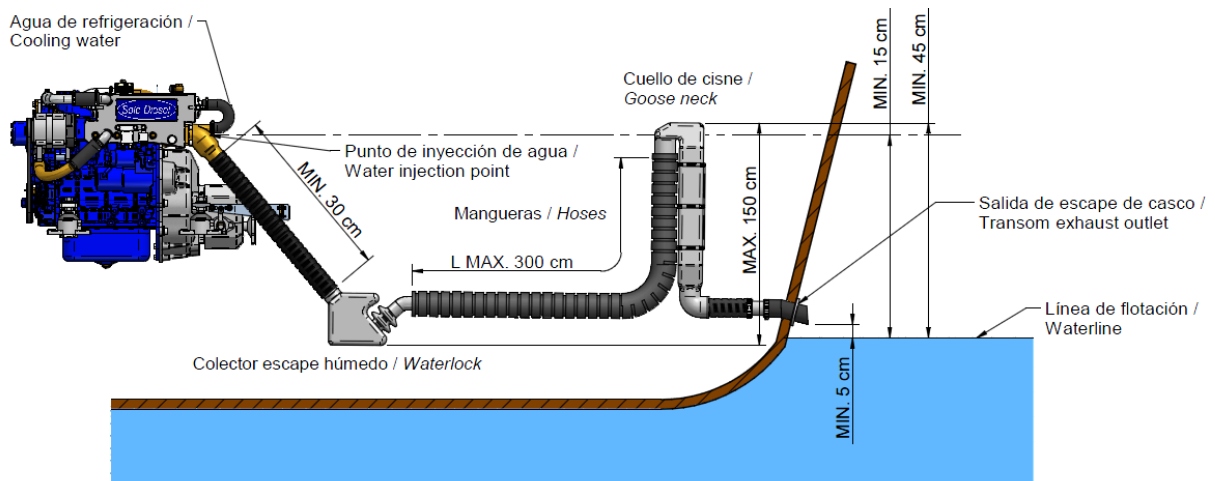

Type 2 installation. When between water injection point of wet exhaust and waterline there is less than 150 mm or the point of injection is below waterline.

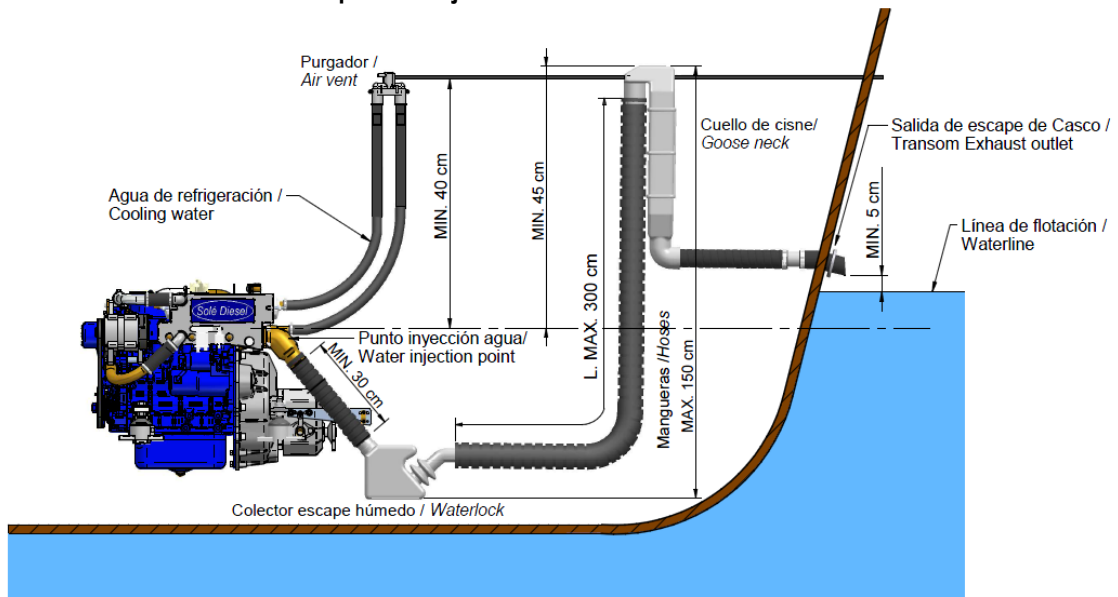

⚠ NOTICE

The wet exhaust is the engine's standard equipment. If you want dry exhaust, which is an optional equipment, contact with our dealers

MAINTENANCE TASK. AIR FILTER INSPECTION

Engine is provided with an intake air filter. Examine the element and housing for damage. Replace the complete air filter if necessary.



⚠ NOTICE

It is important to ensure that the combustion air is freely supplied and freely expelled from the area.

MAINTENANCE TASK. EXHAUST GAS, NOISE AND VIBRATIONS INSPECTION

Inspect the exhaust system components for cracks, leaks and corrosion.

EXHAUST SYSTEM INSPECTION POINTS

1. Check the hoses for softness, cracks or dents. Replace the hoses as needed.
2. Check for corroded or broken metal parts and replace them as needed.
3. Check for loose, corroded or missing clamps. Tighten or replace the hose clamps and/or hangers as needed.
4. Check that the exhaust outlet is unobstructed.
5. Visually inspect the exhaust system for exhaust leaks. Check for carbon or soot residue on exhaust components. Carbon and soot residue indicates an exhaust leak. Seal leaks as needed.

6.8. Electrical System

PANEL SVT

The engine panel is called SVT 30, and you can consult the controller reference according to your engine model in the following table.

On the other hand, you might have a different panel with more instruments called SVT 40. In addition to the option of installing double panel.



NOTICE

More information about the panel can be found in the SVT Operator's Manual.

| ENGINE MODEL | REFERENCE |
|---------------|-----------|
| SM-82 / SM-94 | 60978100 |

BATTERY

The minimum recommended battery capacity is 90 Ah for 12V and 55 Ah for 24V. However, this is a general reference value since it is related to the maximum current that can offer for starting the engine.

CIRCUIT PROTECTION

The electrical installation of the engine has a fuse that protects all the electronics in case of overload or short circuit. It is located in the wire harness next to the starter motor.

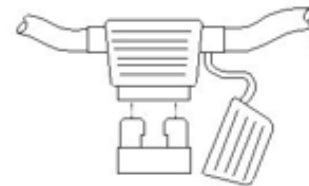

MAINTENANCE TASK. INCANDESCENT GLOW PLUG INSPECTION

1. Loosen nuts, and then remove connection plate and glow plug.

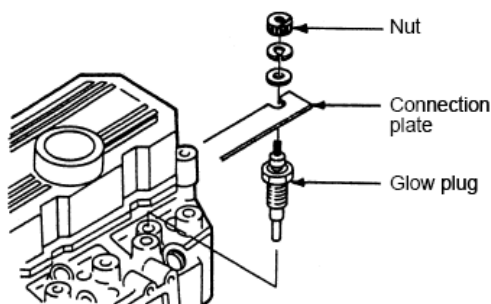

2. If the glow plug glows red when the positive (+) wire is connected to the portion A with the portion B grounded, the plug can be used.

Rated voltage - Current 12 V 5,5 – 11 A

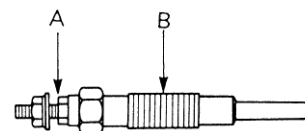

MAINTENANCE TASK. STARTER MOTOR INSPECTION

STARTER MOTOR:

1. Check if there is any impurity in pinion teeth.
2. Make sure that the pinion shaft turns freely when turned in the direction of driving (clockwise) and it is locked when turned in the opposite direction. If not, replace the overrunning clutch.

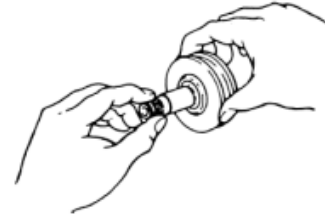

MAINTENANCE TASK. ALTERNATOR BELT TENSION INSPECTION

Push the belt inward with thumb pressure exerted midway between the pulleys, as shown, to check the belt tension (deflection). If the tension is incorrect, loosen the adjusting bracket bolt and mounting bolt, and move the alternator in or out.

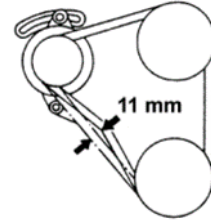

| Item | Assembly Standard |
|-------------------|-------------------|
| V-belt deflection | 10-12 mm |

NOTICE

An excessive tension may cause a quick wear of the belt and alternator bearings. Otherwise, if the belt is excessively loose or has oil and insufficient load, it can cause the belt to skid.

CAUTION

Never adjust the belt tension with engine running or battery connected.

MAINTENANCE TASK. BATTERY LEVEL

Battery requires a very careful handling and frequent checking. Proceed as shown below:

1. Keep battery dry and cleaned.
2. Check terminal cleanliness regularly. If dust is settled, terminals should be loosened, cleaned and smeared with a neutral grease layer.
3. Metal objects must not be placed over the battery.
4. Add distilled water if the level is out of range.

Section 7 - Troubleshooting

If a fault occurs in the engine, proceed as follows:

- ❖ Within the period of warranty
 - Contact to Sole Diesel Official Service. See *Section 1, 1.3. Engine Limited Warranty*

- ❖ Outside the period of warranty
 - Contact to Sole Diesel Official Service. See *Section 1, 1.3. Engine Limited Warranty*
 - Stop the engine, determine the cause and repair it before continuing driving the motor.

TROUBLESHOOTING

| ENGINE FAILURE | PROBABLE CAUSES | | RECOMMENDED ACTIONS | SECTION |
|------------------|--------------------------|--|--|---------|
| FAILURE TO START | PANEL SVT | Key switch | Check the pin connections and check that they have voltage. | - |
| | | Electronic board | Check that goes voltage electronic board to micro relay. | - |
| | ELECTRICAL SYSTEM ENGINE | Blown fuse | Replace the controller fuse. If the fuse blows again, troubleshoot the controller. | 6.8 |
| | | Battery discharged or dead | Recharge or replace the battery. | 6.8 |
| | | Battery connections loose, corroded or incorrect | Verify that the battery connections are correct, clean and tight. | 6.8 |
| | | Faulty cranking relay/stop solenoid | Check the cranking relay and the stop solenoid. If necessary, replace. | - |
| | | Faulty starter motor | Replace if it is inoperative. | 6.8 |
| | GENERAL | Compression weak | Check the compression. | 6.3 |
| | LUBRICATION SYSTEM | Oil viscosity too high | Check the oil viscosity (according to technical specifications). | 6.4 |
| | FUEL SYSTEM | Fuel pump faulty or clogged | Check fuel pump inlet. | 6.5 |
| | | Fuel lines obstructed | Check fuel lines. | 6.5 |
| | | Fuel filter clogged | Replace fuel filter. | 6.5 |
| | | Faulty injection pump | Contact with our dealer | - |
| | | Air in fuel system | Bleed fuel system. | 6.5 |
| | | Fuel injectors dirty or faulty | Clean, test and/or replace the inoperative fuel injector. | 6.5 |
| | | Fuel injection timing out of adjustment | Adjust the fuel injection timing. | 6.5 |
| | | Fuel tank empty or fuel valve shut off | Add fuel and move the fuel valve to opened position. | 6.5 |
| | INLET AND EXHAUST SYSTEM | Air filter clogged | Replace air filter element. | 6.7 |

TROUBLESHOOTING

| ENGINE FAILURE | PROBABLE CAUSES | | RECOMMENDED ACTIONS | SECTION |
|--------------------------|--------------------------|---|--|---------|
| STARTS THEN STOPS | GENERAL | Governor inoperative | Contact with our dealer | - |
| | FUEL SYSTEM | Fuel pump faulty or clogged | Check inlet of fuel pump. | 6.5 |
| | | Fuel filter clogged | Replace fuel filter. | 6.5 |
| | | Air in fuel system | Bleed fuel system. | 6.5 |
| | | Injection pump incorrectly set | Contact with our dealer | - |
| | | Fuel outlet cock closed | Open fuel outlet cock. | 6.5 |
| | COOLING SYSTEM | Coolant level low | Restore the coolant to normal operating level. | 6.6 |
| PANEL SVT | Key switch | Check the pin connections. Above all, the pins that give signal to stop solenoid and fuel pump. | - | |
| BLACK SMOKE | FUEL SYSTEM | Fuel filter clogged | Change fuel filter. | 6.5 |
| | | Fuel injectors dirty or faulty | Clean, test and/or replace the inoperative fuel injector. | 6.5 |
| | | Injection pump incorrectly set | Contact with our dealer | - |
| | INLET AND EXHAUST SYSTEM | Air filter clogged | Replace air filter element. | 6.7 |
| | LOAD ENGINE | Propeller too large (not enough rpm) | The power curve of the engine is not adequate. Carry out a propulsive power study. | - |
| BLUE SMOKE | GENERAL | Valve clearance incorrect | Adjust the valves. | 6.3 |
| | LUBRICATION SYSTEM | Oil level too high | Restore the oil to normal operating level. | 6.4 |



TROUBLESHOOTING

| ENGINE FAILURE | PROBABLE CAUSES | | RECOMMENDED ACTIONS | SECTION | |
|-------------------------------------|--------------------------|-------------------------------------|---|-------------------------|-----|
| ENGINE OVER-HEATING | GENERAL | Compression weak | Check the compression. | 6.3 | |
| | | Overload | Propeller too large, replace. | - | |
| | | Incorrect injection time | Adjust the injection time of the injection pump. | | |
| | LUBRICATION SYSTEM | Faulty oil pump | Contact with our dealer | - | |
| | | Oil viscosity too high | Check oil specifications (oil used must be chosen according to Technical Specifications). | 6.4 | |
| | | Oil level too low | Restore the oil level. Inspect the engine for oil leaks. | 6.4 | |
| | COOLING SYSTEM | Faulty coolant pump | Check coolant pump (impeller, pump sealing). | 6.6 | |
| | | Seawater cock clogged or restricted | Clean the cock, check the seawater pump impeller for damage. | 6.6 | |
| | | Faulty seawater pump | Check seawater pump (impeller, pump sealing). | 6.6 | |
| | | Water cooler clogged | Clean the water cooler and the tube stack fitted in the heat exchanger. | 6.6 | |
| | | Coolant level low | Restore the coolant to normal operating level. | 6.6 | |
| | | Thermostat inoperative | Replace the thermostat. | 6.6 | |
| | INLET AND EXHAUST SYSTEM | Air filter clogged | Replace air filter. | 6.7 | |
| | LOW OIL PRESSURE | LUBRICATION SYSTEM | Faulty oil pump | Contact with our dealer | - |
| | | | Oil pressure relief valve sticking | | 6.4 |
| Oil pressure too low | | | Check oil level. | 6.4 | |
| Oil level too low | | | Restore the oil level. Inspect the engine for oil leaks. | 6.4 | |
| Faulty oil pressure valve | | | Contact with our dealer | - | |
| Faulty oil pressure gauge or switch | | | Check and/or replace oil pressure switch. | 6.4 | |
| NOISY ENGINE | GENERAL | Compression weak | Check the compression. | 6.3 | |
| | | Overload | Reduce the electrical load. | 6.3 | |
| | | Exhaust system leak | Inspect the exhaust system. Replace the inoperative exhaust system components. | 6.3 | |
| | | Vibration excessive | Tighten all loose nuts and bolts. | 6.3 | |
| | | Valve clearance incorrect | Adjust the valves. | 6.3 | |



TROUBLESHOOTING

| ENGINE FAILURE | PROBABLE CAUSES | | RECOMMENDED ACTIONS | SECTION |
|---------------------------------|------------------------------|--|--|------------------------|
| OIL PRESSURE TOO HIGH | LUBRICATION SYSTEM | Oil pressure relief valve sticking | Contact with our dealer | 6.4 |
| | | Faulty oil pressure valve | Contact with our dealer | - |
| LOW POWER | GENERAL | Valve clearance incorrect | Contact with our dealer | 6.3 |
| | FUEL SYSTEM | Fuel filter clogged | Contact with our dealer | 6.5 |
| | | Fuel injectors dirty or faulty | Contact with our dealer | 6.5 |
| | | Water in fuel system | Contact with our dealer | 6.5 |
| | | Fuel injection timing out of adjustment | Contact with our dealer | 6.5 |
| | INLET AND EXHAUST SYSTEM | Air filter clogged | Replace air filter element. | 6.7 |
| | | Exhaust backfires | Inspect the exhaust system. Replace the inoperative exhaust system components. | 6.7 |
| | HIGH FUEL CONSUMPTION | GENERAL | Compression weak | Check the compression. |
| Overload | | | Reduce the electrical load. | 6.3 |
| Governor inoperative | | | Contact with our dealer | - |
| FUEL SYSTEM | | Fuel injection timing out of adjustment | Adjust the fuel injection timing. | 6.5 |
| INLET AND EXHAUST SYSTEM | | Air filter clogged | Replace air filter. | 6.7 |
| COOLING SYSTEM | | Thermostat blocked at open position | Replace thermostat and check the coolant state. | - |
| BATTERY CHARGE DEFECTIVE | ELECTRICAL SYSTEM (DC) | Battery discharged or dead | Recharge or replace the battery. | 6.8 |
| | | Battery connections loose, corroded or incorrect | Verify that the battery connections are correct, clean and tight. | 6.8 |
| | | Governor inoperative | Contact with our dealer | - |
| | | Alternator belt tension | Check belt tension and change it if necessary. | 6.8 |

Section 8 – Technical Specifications

| | | SM-82 | SM-94 |
|-------------------------------|--|---|--------------|
| DIESEL ENGINE | | | |
| General Specifications | Type | 4 cycle water-cooled, diesel cycle | |
| | Direction of rotation | Anti-clockwise rotation as viewed from flywheel side | |
| | No. of cylinders - arrangement | 4 in line | 4 in line |
| | Allowable Exhaust Back Pressure (kPa) | Max. 12 kPa | Max. 15 kPa |
| | Timing | Pushrod and rocker arm with gear driven camshaft in crankcase | |
| | Bore (mm) | 94 | 94 |
| | Stroke (mm) | 120 | 120 |
| | Total displacement (c.c.) | 3331 | 3331 |
| | Compression ratio | 19,5:1 | 19:1 |
| | Ignition sequence | 1-3-4-2 | 1-3-4-2 |
| | Fuel injection timing | APMS 5° | APMS 5° |
| | Injection pressure (kPa) | 17,65 MPa (180 kg/cm ²) | |
| | Inlet and exhaust valve clearance - cold engine (mm) | 0,25 | |
| | Power (kW / HP) | 60,3 / 82,01 | 69,0 / 93,84 |
| | RPM (rpm) | 2500 | |
| | Starting system | Electric starting | |
| | Starting aid | Glow plug | |
| Lubrication system | System description | Forced circulation by gear pump | |
| | Oil specifications | Use oil with 15W40 viscosity and no less than ACEA E5/E3 or API CH-4/SJ quality | |
| | Oil pump | Gear type | |
| | Oil circuit capacity (l) | 10 | 10 |
| | Lubrication oil pressure – nominal speed (MPa) | 0,19 (2 kgf/cm ²) (2 bar) | |
| | Min oil pressure - hot engine (MPa) | 0,39 (4 kgf/cm ²) (4 bar) | |
| | Oil temperature – nominal speed (°C) | 0,1 (1 kg/cm ²) (1 bar) | |
| Fuel system | System description | 60 - 95 | |
| | System description | Electric fuel pump and mechanic injection pump | |
| | Fuel specifications | Diesel fuel ASTM diesel No.2-D | |
| | Fuel injection pump | In line type | |
| Fuel injection nozzle | Throttle type | | |

| DIESEL ENGINE | | | |
|--------------------------|--|---|----------|
| Cooling system | System description | Coolant circulation controlled by centrifugal pump with thermostatic control and heat exchanger. Cooled exhaust manifold. | |
| | Coolant specifications | KRAFFT ACU 2300 CC 50% | |
| | Coolant pump | Centrifugal type | |
| | Sea water pump | Centrifugal type | |
| | Coolant circuit capacity (l) | 11 | 11 |
| | Thermostat valve | | |
| | Start opening | + 76,5°C | |
| | End opening | + 90°C | |
| | Coolant temperature – nominal speed (°C) | 75 - 85 | |
| Inlet and Exhaust System | Air supply | Air cleaning by means of a dry-type air filter | |
| | Exhaust System Air supply | Cooled exhaust manifold Dry exhaust manifold (optional equipment) Air cleaning by means of a dry-type air filter | |
| Electrical System | Voltage – Polarity (V) | 12 DC | |
| | Alternator DC (A) | 75 | 75 |
| | Starter motor (kW) | 2,2 | 2,2 |
| | Glow plugs (A) | ETR | |
| Installation | Ø Int. Hose, sea water inlet (mm) | 20 | |
| | Ø Int. Hose, diesel fuel inlet (mm) | 8 | |
| | Ø Int. Hose, exhaust outlet ¹ (mm) | 40 | 50 |
| | Air admission displacement -max. rpm (m ³ /h) | 1 | 1,5 |
| | Minimum battery capacity (Ah) | 75 (12V) | 80 (12V) |
| | Length of battery wire (m) | ≤ 1,5 | |
| | Minimal section of battery wire (mm ²) | 60 | |

¹ For each curve of 90° of the installation, must increase 10 mm (for lengths superior to 3 m).

Section 9 – Tightening Torques

Important nuts and screws.

| TORQUE VALUES | THREAD | SM-82 / SM-94 |
|---------------------------------|--------------|-------------------------------|
| | | N · m (kgf · m) |
| Cylinder head | M12 | 112.8 to 122.6 (11.5 to 12.5) |
| Rocker shaft brackets | M8 | 9.8 to 19.6 (1.0 to 2.0) |
| Main bearing caps | M14 | 98 to 107.8 (10.0 to 11.0) |
| Connecting rod caps | M10 | 49 to 58.8 (5.0 to 6.0) |
| Rocker cover | M8 | 70.6 to 92.1 (7.2 to 9.4) |
| Flywheel | M12 | 78.4 to 88.2 (8.0 to 9.0) |
| Crankshaft pulley | M30 | 29.4 to 39.2 (3.0 to 4.0) |
| Oil pan drain plug | M14 | 34.3 to 44.1 (3.5 to 4.5) |
| Oil pan | M8 | 9.8 to 12.7 (1.0 to 1.3) |
| Oil pressure relief valve | M22 | 44.1 to 53.9 (4.5 to 5.5) |
| Fuel filter | M8 | 23 (2.34) |
| Safety valve or blind plug | M18 | 63.7 to 73.5 (6.5 to 7.5) |
| Glow plug | M12 | 19.6 to 29.4 (2.0 to 3.0) |
| Coolant drain plug | ¼ - 18NPTF | 35.3 to 43.14 (3.6 to 4.4) |
| Fuel injection pipe | M12 | 26.47 to 32.36 (2.7 to 3.3) |
| Fuel injection pump gear | M14 | 83.3 a 98 (8.5 a 10) |
| Fuel injection nozzle | M8 | 19.6 a 23.5 (2.0 a 2.4) |
| Water cooler cover | M10 | 18.5 a 22.3 (1.89 a 2.27) |
| Seawater pump cover | M6 | 7.4 a 9.0 (0.75 a 0.92) |
| Seawater pump to engine | M6 | 7.4 a 9.0 (0.75 a 0.92) |
| Engine bracket bolt | - | 82.0 a 97.5 (8.36 a 9.94) |
| Alternator bracket bolt | M10 | 21.7 a 24.2 (2.21 a 2.47) |
| Heat exchanger to cylinder head | M8 | 21.7 a 24.2 (2.21 a 2.47) |
| Turbo bracket nuts | DIN 934 | 35.5 a 44.5 (3.62 a 4.54) |
| Thermostat cover | M8 | 18.5 a 22.3 (1.89 a 2.27) |
| Water cooler to cylinder head | M8 | 18.5 a 22.3 (1.89 a 2.27) |
| Starter terminal B | M8 | 9.8 a 11.7 (1.0 a 1.2) |
| Standard Bolts | M6 | 2.9 to 4.9 (0.3 to 0.5) |
| | M8 | 9.8 to 12.7 (1.0 to 1.3) |
| | M10 | 17.6 to 24.5 (1.8 to 2.5) |
| | M12 | 29.4 to 41.1 (3.0 to 4.2) |
| Standard Studs | M8 | 4.9 to 5.8 (0.5 to 0.6) |
| | M10 | 12.7 to 14.7 (1.3 to 1.5) |
| Standard plugs | Nptf 1/6 | 4.9 to 7.8 (0.5 to 0.8) |
| | PT 1/8 | 7.8 to 11.7 (0.8 to 1.2) |
| | PT ¼, NPTF ¼ | 19.6 to 29.4 (2.0 to 3.0) |

Section 10 – Wiring Diagrams

Detalle relé bujías precalentamiento / Preheating relay

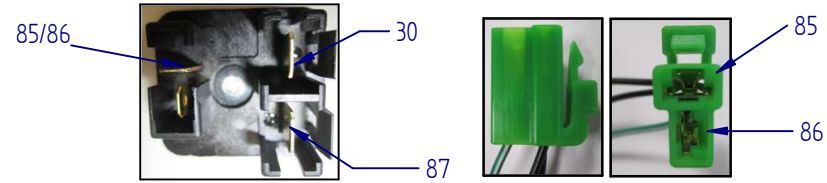

Detalle relé de aislamiento / Isolating relay

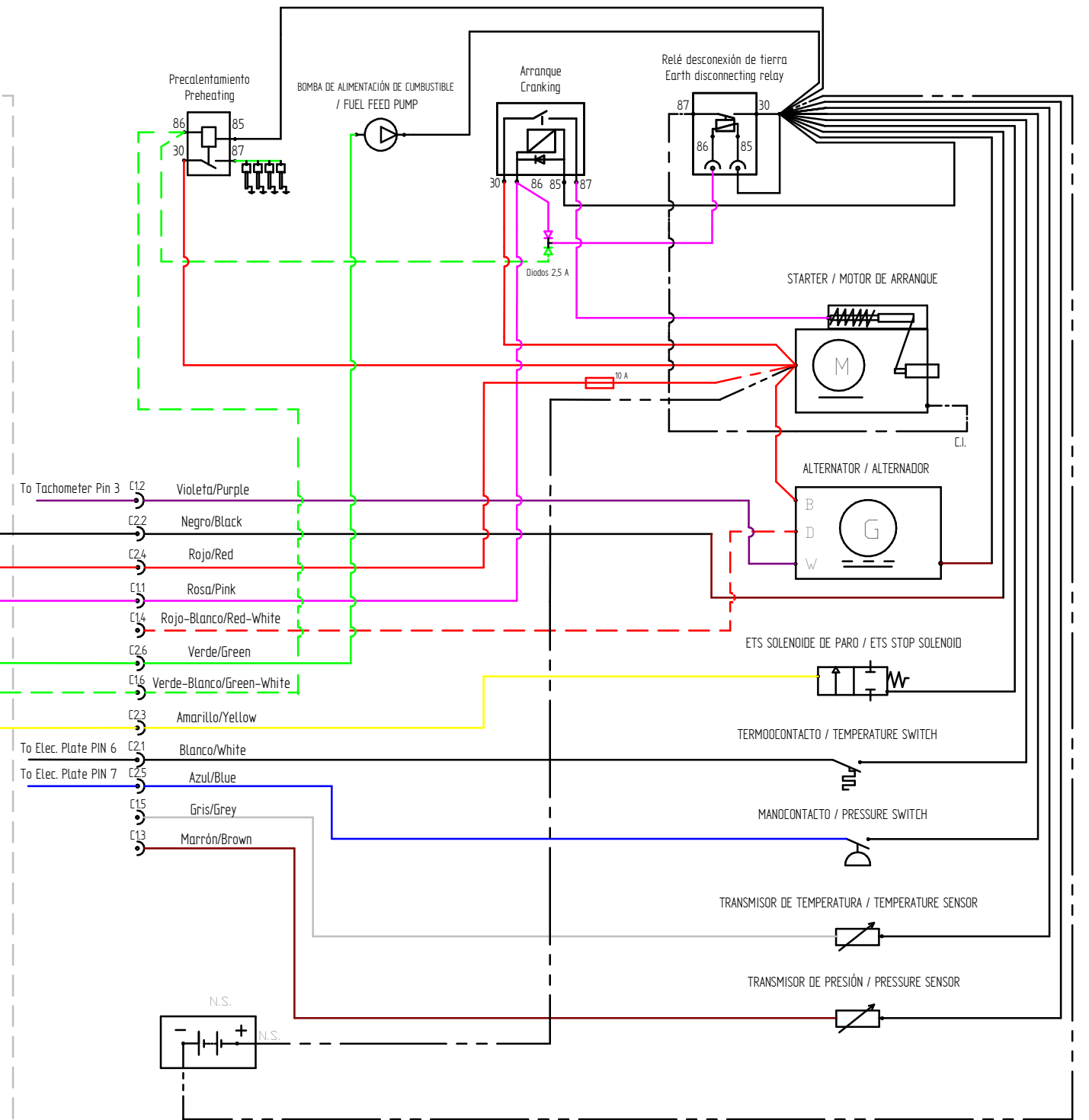
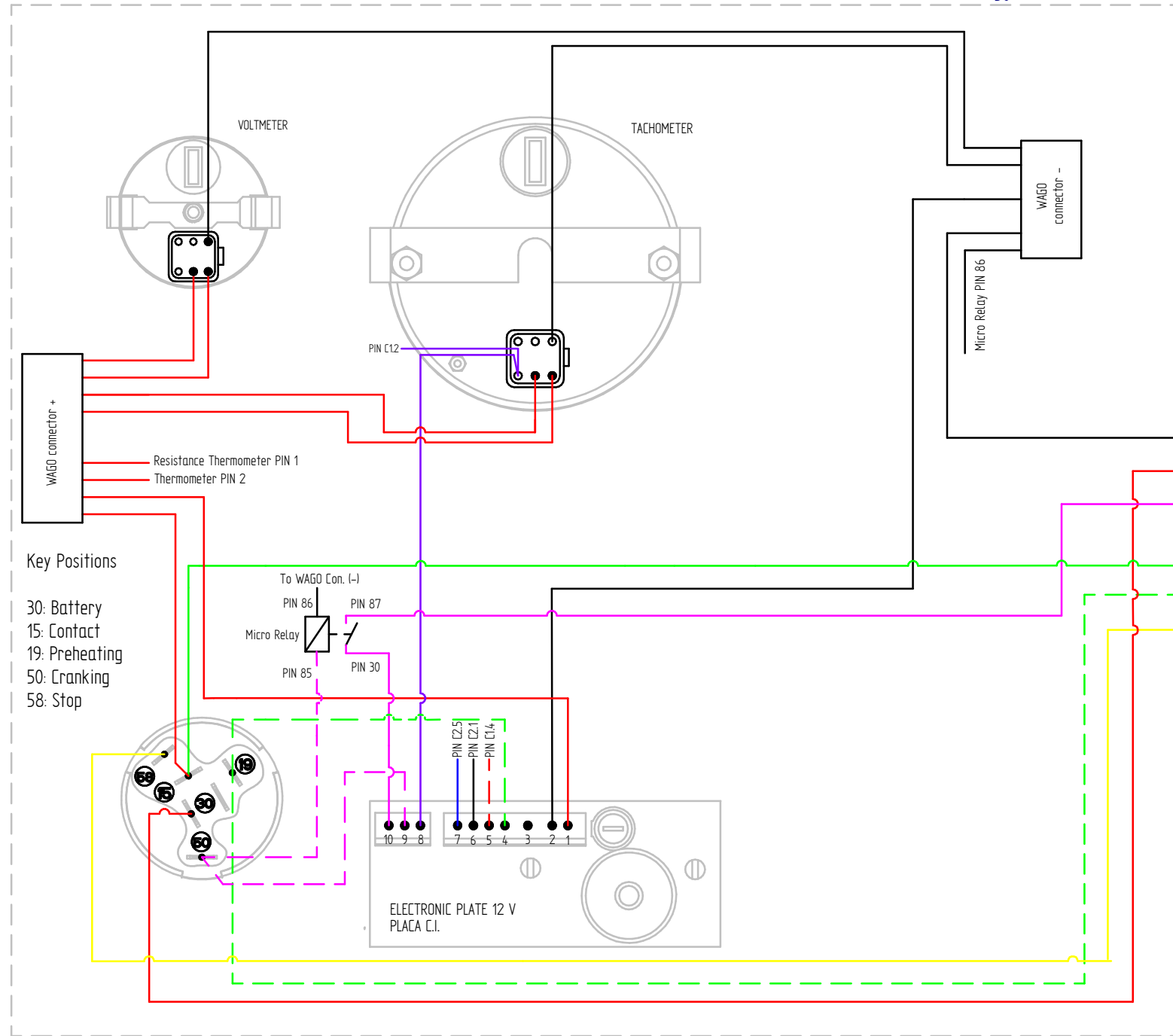
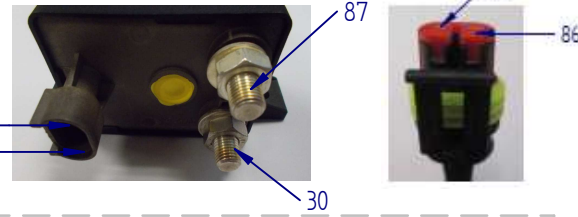

Detalle relés de arranque / Starter relay

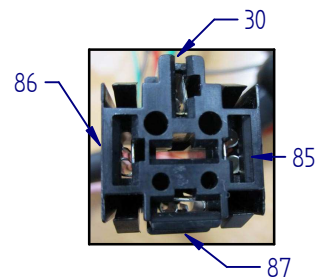

Conector 1: C1 / Connector 1: C1

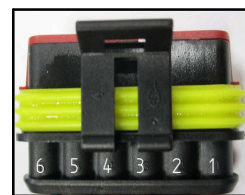

Conector 2: C2 / Connector 2: C2



DEUTSCH CONNECTOR

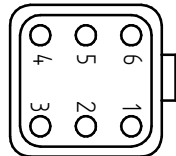

LEYENDA / LEGEND:
 - N.S.: NO SUMINISTRADO / NOT SUPPLIED
 - OPT.: OPCIONAL / OPTIONAL

| | | | | |
|---------------------------------|--------------------------|---|-----------------|--------|
| MODELO MOTOR / ENGINE MODEL: | | MINI-17 / MINI-29 - LIBRE MASA/EARTH ISOLATED | | |
| VOLTAGE MOTOR / ENGINE VOLTAGE: | | 12 V | | |
| PANEL REF: | | 60938130 | | |
| ELEC. WIRING REF.: | | 60938205 | | |
| DIBUJADO D.SEGURA | VERIFICADO V. MIRAVET | FECHA CREACIÓN 12/05/2016 | ÚLTIMA REVISIÓN | PÁGINA |
| SOLÉ, S.A. | | E1380B01P_SVT | .- | 1 de 1 |

Detalle relé bujías precalentamiento / Preheating relay

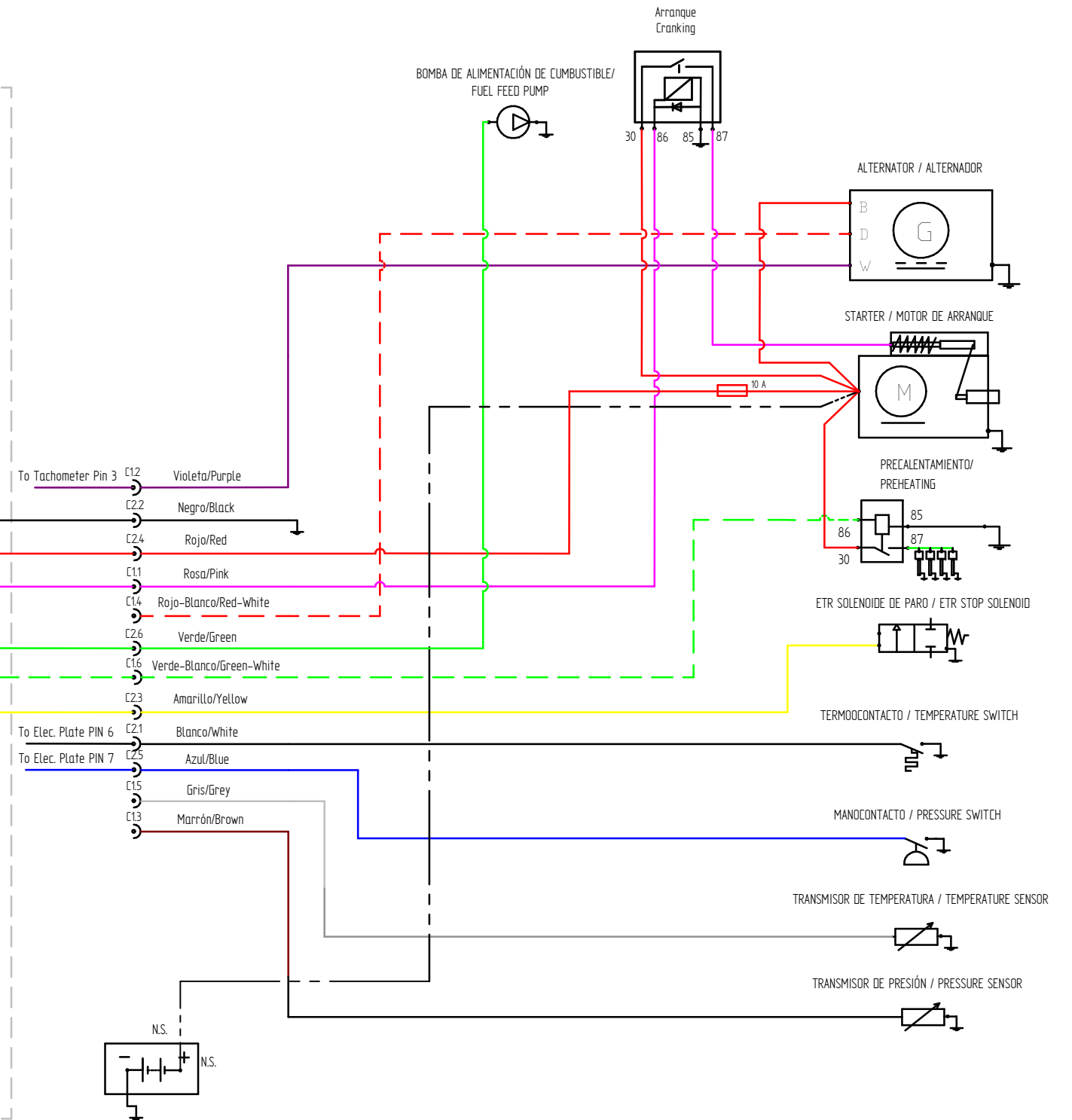
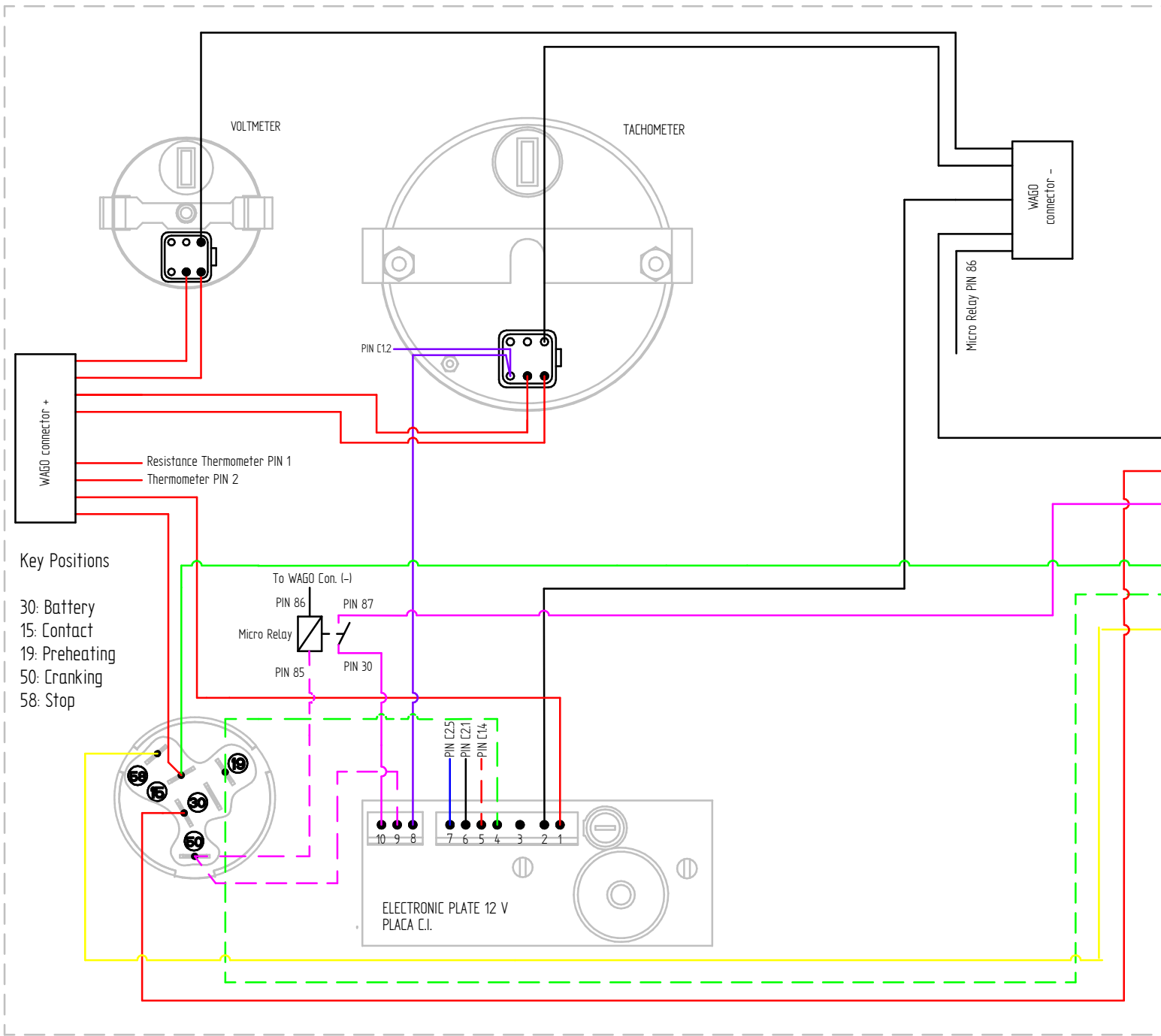
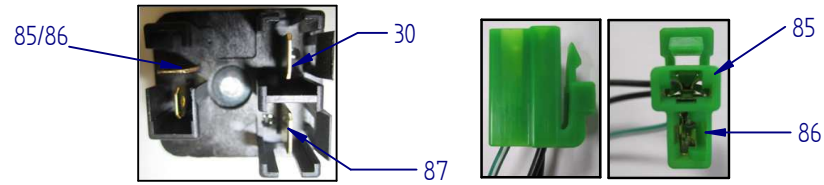

Detalle relés de arranque / Starter relay

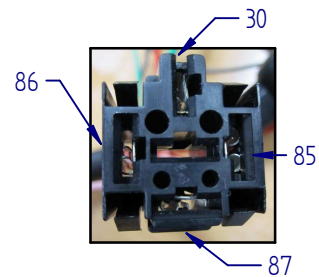

Conector 1: C1 / Connector 1: C1

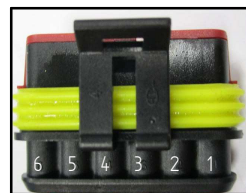

Conector 2: C2 / Connector 2: C2



DEUTSCH CONNECTOR

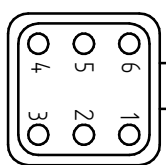

LEYENDA / LEGEND:
 - N.S.: NO SUMINISTRADO / NOT SUPPLIED
 - OPT.: OPCIONAL / OPTIONAL

| | | | | |
|---------------------------------|--------------------------|------------------------------|-----------------|--------|
| MODELO MOTOR / ENGINE MODEL: | | MINI-17 / MINI-29 | | |
| VOLTAGE MOTOR / ENGINE VOLTAGE: | | 12 V | | |
| PANEL REF: | | 60938130 | | |
| ELEC. WIRING REF.: | | 60938204 | | |
| DIBUJADO D.SEGURA | VERIFICADO V. MIRAVET | FECHA CREACIÓN 14/04/2016 | ÚLTIMA REVISIÓN | PÁGINA |
| SOLE, S.A. | | E1380E01P_SVT | | 1 de 1 |

Section 11 – Overall Dimensions

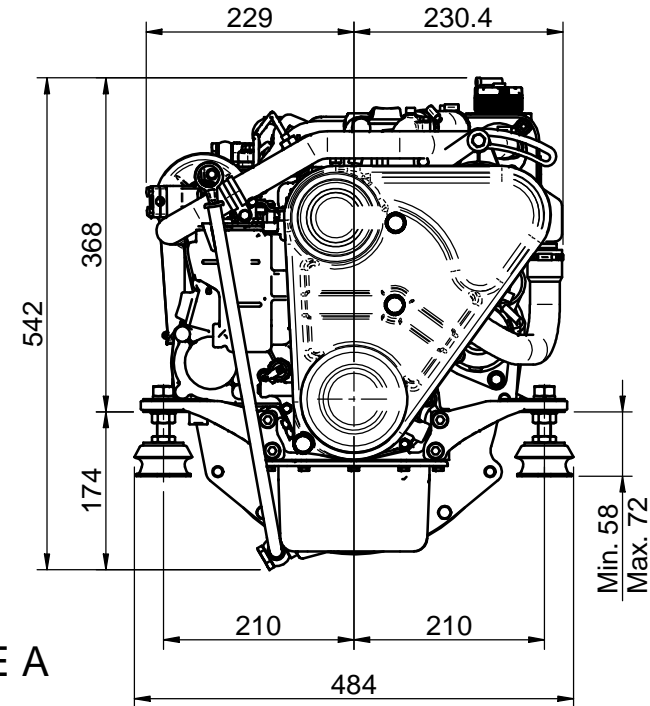
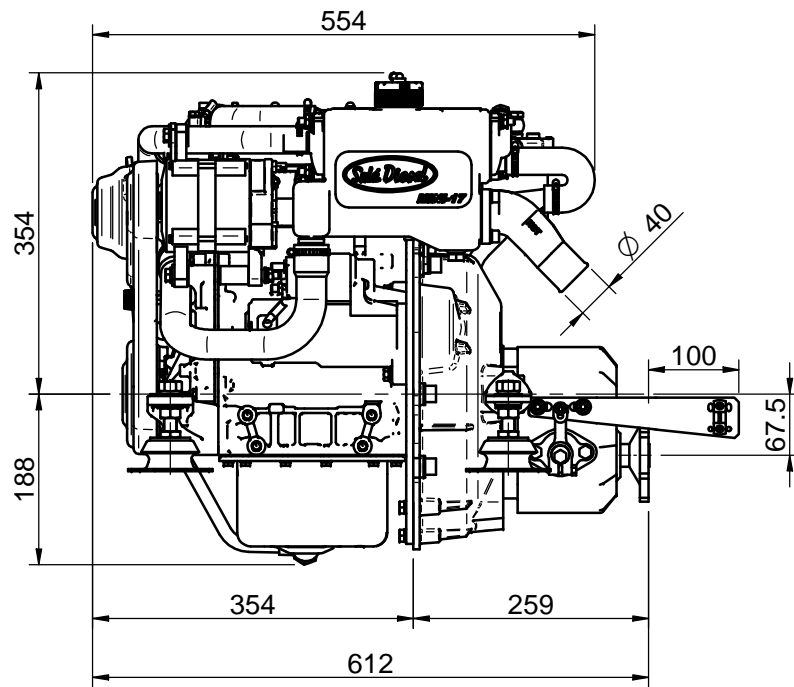

DETALLE A

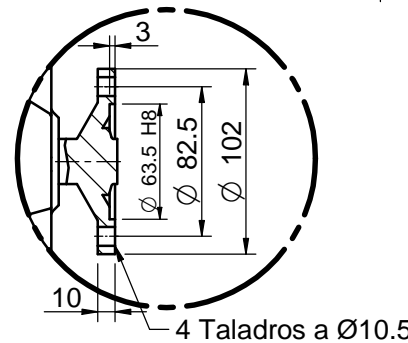
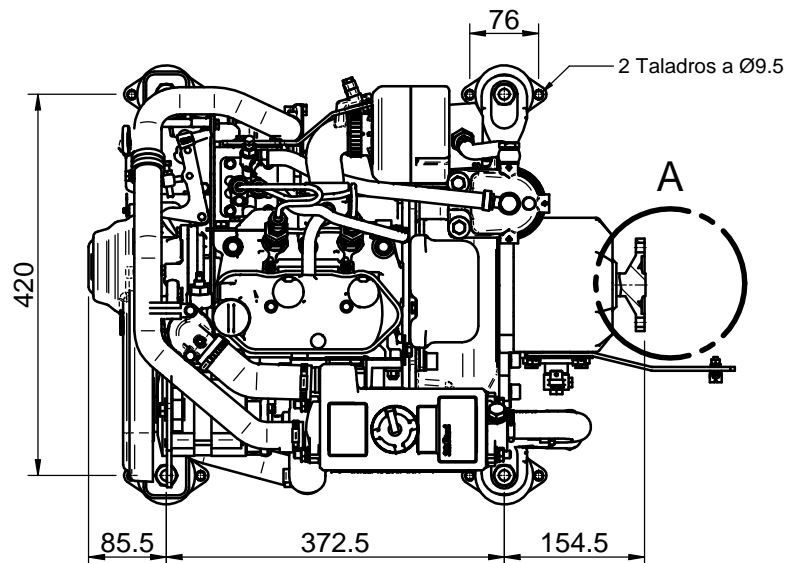

| DATOS TÉCNICOS / TECHNICAL DATA | |
|---|-------|
| (1) Manguera entrada agua salada / Sea water hose intake: | Ø20mm |
| (2) Manguera entrada combustible / Fuel hose intake: | Ø8mm |
| (3) Manguera retorno combustible / Diesel Fuel return hose: | Ø5mm |

| | | | | |
|--|------------|-------------------|-------------------|-----------------|
| MOTOR MINI-17 v6 INV. TMC-40 2,60:1 | | | | |
| MINI-17 v6 ENGINE TMC-40 2.60:1 GBOX. | | | | |
| MATERIAL | ACABADO | TRATAMIENTO | PRESENTACIÓN | ESCALA |
| DIBUJADO | VERIFICADO | GRADO PRECISIÓN | FECHA CREACIÓN | ÚLTIMA REVISIÓN |
| X.MARGARIT | S. UBACH | MEDIO | 17/12/2015 | --- |
| | | SOLÉ, S.A. | 13830264.6 | |

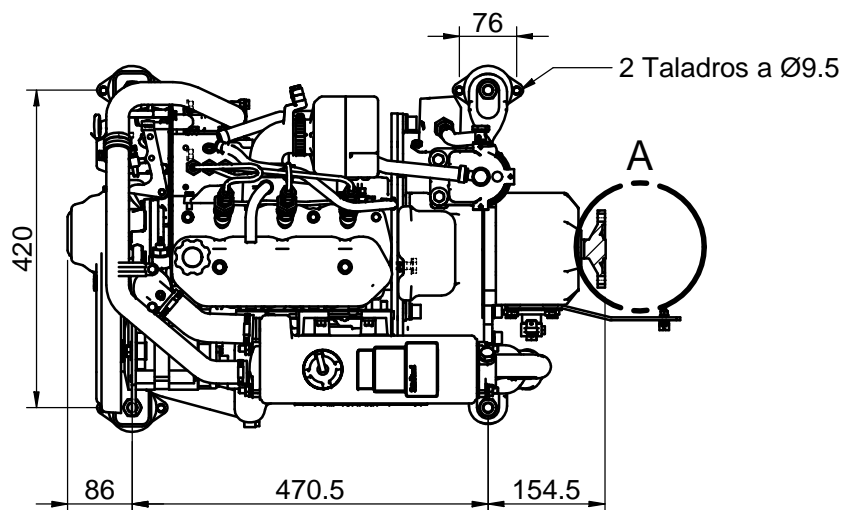
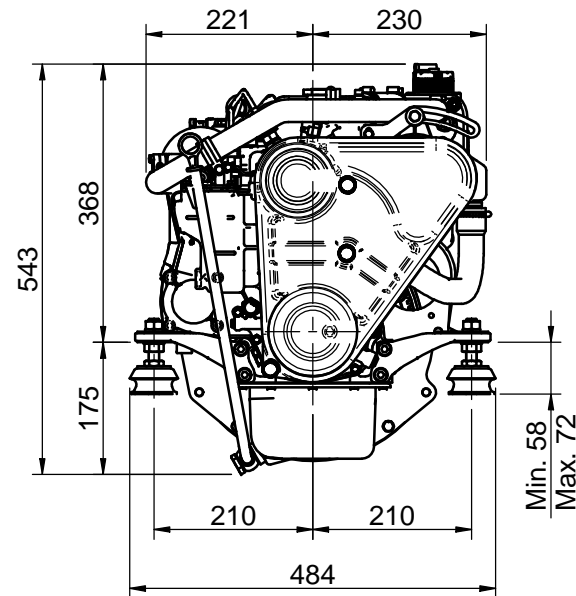
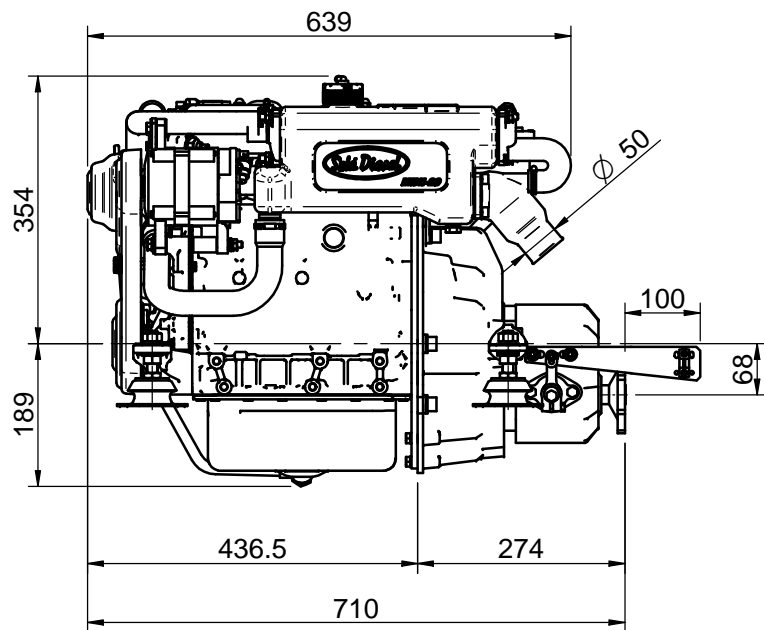

DETALLE A

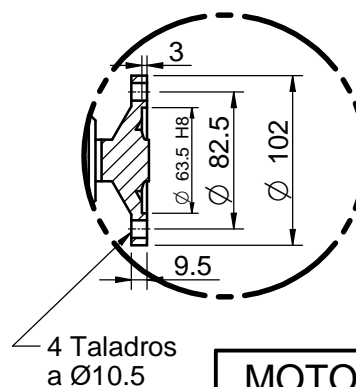

| DATOS TÉCNICOS / TECHNICAL DATA | |
|---|-------|
| (1) Manguera entrada agua salada / Sea water hose intake: | Ø20mm |
| (2) Manguera entrada combustible / Fuel hose intake: | Ø8mm |
| (3) Manguera retorno combustible / Diesel Fuel return hose: | Ø5mm |

| | | | | |
|--|------------|-------------------|-------------------|-----------------|
| MOTOR MINI-29 v6 INV. TMC-40P 2,00:1 | | | | |
| MINI 29 v6 ENGINE TMC-40P 2.00:1 GBOX | | | | |
| MATERIAL | ACABADO | TRATAMIENTO | PRESENTACIÓN | ESCALA |
| DIBUJADO | VERIFICADO | GRADO PRECISIÓN | FECHA CREACIÓN | ÚLTIMA REVISIÓN |
| X.MARGARIT | S. UBACH | MEDIO | 12/01/2016 | --- |
| | | SOLÉ, S.A. | 17633100.6 | |

Section 12 - Instructions to Replace and Remove

When you decide to replace the engine, please contact SOLÉ S.A.; will provide relevant instructions regarding the laws in force at the time. When disposing of the whole or parts of this engine, meets LAWS IN FORCE IN THE COUNTRY OF INSTALLATION.

For more information about the materials they are made of the individual components of the generator, contact SOLÉ S.A.

| INSPECTION PRIOR TO THE DELIVERY OF PROPULSION ENGINES | | | | |
|--|-----------|--|---|--------------------------|
| Installer / Marina information | | | | |
| Installer Company: | | | Installation Date: | |
| Contact Tel. no.: | | | E-mail: | |
| Owner's Information | | | | |
| Name and surnames: | | | | |
| Contact Tel. no.: | | | Email: | |
| Engine Information | | | | |
| Engine model: | | | | |
| Engine serial number: | | | Gearbox / Saildrive serial n°: | |
| Installation Information | | | | |
| Machine chamber operating temperature: | | | | °C |
| Angle of the engine (boat moored): | | | | ° |
| Maximum angle of the engine (navigation conditions): | | | | ° |
| Is the wet exhaust elbow above or below the floating line? | | | above | below |
| Propulsion Line Information | | | | |
| Boat model: | | | Gearbox / Saildrive transmission ratio: | |
| Shaft diameter: | | mm | Shaft length: mm | |
| Propeller diameter: | mm/inches | Propeller pitch: | mm/inches | N°. Of propeller blades: |
| Exhaus, Cooling and Fuel Line Information | | | | |
| Int. Diameter of exhaust hose: | mm | Int. Diameter of sea water intake to the pump: | mm | |
| Int. Diameter of diesel intake: | mm | | | |
| Int. Diameter of diesel return intake: | mm | | | |
| Has an exhaust collector been installed? | YES NO | Has an air trap been installed? | YES NO | |
| Verifications Prior to Start-Up | | V/x | Notes | |
| Correct engine alignment. | | | | |
| Electrical installation connections | | | | |
| Engine oil level | | | | |
| Gearbox oil level. | | | | |
| Coolant level and concentration | | | | |
| Control lever operation | | | | |
| Transmissions belts and belt tension | | | | |
| Airtight sea water cock. | | | | |
| Verification of Engine No-Load Operations | | V/x | Notes | |
| Unusual noises from the transmission | | | | |
| Oil pressure | | | | |
| Bleed the fresh water cooling system | | | | |
| Verify the instrument panel: normal indications and alarm operation. | | | | |
| Water, oil and fuel leaks in the engine or transmission. | | | | |

| INSPECTION PRIOR TO THE DELIVERY OF PROPULSION ENGINES | | |
|---|-----|-------|
| Verification of Motor Operating with Propeller Load | V/x | Notes |
| Verify maximum engine rpm at full load and with forward gear clutched. This test should be performed with the engine heated up. (If top rpm is not achieved contact Solé to inspect propeller dimensions) | rpm | |
| Engine rpm with engine idling and clutch out | rpm | |
| Engine output and inverter operation. Verify operation of the Trolling valve, if applicable. | | |
| Engine temperature and oil pressure. | | |
| Information for the Owner | V/x | Notes |
| Delivery of the instructions manual and engine-related documents. | | |
| Review of the engine instructions manual | | |
| Study the instruments panel functions and the engine control functions. | | |
| Report the first revision date. | | |
| Report the maintenance schedule indicated in the manuals. | | |



SOLÉ, S.A.

C-243 b, km 2. 08760 Martorell. Barcelona
Tel. +34 93 775 14 00 · Fax +34 93 775 30 13
www.solediesel.com · info@solediesel.com



MARINE DIESEL ENGINES · GENSETS · PROPELLERS · ACCESSORIES

www.solediesel.com

Follow us on:



Detailed drawings, leaflets and manuals are available at www.solediesel.com. © 2016. Solé Diesel. All rights reserved. Texts and specifications are subject to change without notice and without any obligation or liability whatsoever.



U_MIE1_EN

Rev. 1