

LM92 | METROPOLITAN - Design: Larsen & Bender Madsen



DESCRIPTION

Originally intended as a conference chair, the Metropolitan Chair went into production in 1950. The design is the result of many intense hours where Larsen and Bender Madsen designed and developed late into the night. The tensioned veneer back was inspired by a lamination technique course Bender Madsen had taken earlier.

HISTORY

After a 1961 Danish export campaign, the Metropolitan Museum in New York purchased the chair for its exhibition, The Arts of Denmark. The chair was consequently named the Metropolitan Chair - probably one of the greatest honors a chair can earn. Chase Manhattan Bank also expressed an interest in purchasing 450 of the chairs for their new head office.

The chair was previously made primarily of teak, oak, and occasionally cherry wood. A decade after the original version was unveiled, it was supplemented with a saddle leather seat and backrest.

THE DESIGNER

Ejner Larsen (1917-1987)

Ejner Larsen completed his training as a decorator and upholsterer in 1936 and went on to study furniture at the Royal Danish Academy of Fine Arts, graduating in 1940. He taught at the Academy from 1942 until 1957 while working for various prominent cabinetmakers. Later on Larsen was

appointed head of the architecture department at the Christiansborg Palace Administration and from 1977 onwards he worked as a State and Castle Inventory Inspector, resigning in 1986 due to illness.

Aksel Bender Madsen (1916-2000)

Aksel Bender Madsen completed his cabinetmaker training in 1936 and subsequently studied furniture at the Royal Danish Academy of Fine Arts, graduating in 1940. He worked for leading Danish designers Kaare Klint and Arne Jacobsen from 1940 to 1943 and then at the architecture office of the Danish Consumers Cooperative Society from 1943 to 1950. Additionally, Bender Madsen taught furniture courses at the Royal Danish Academy of Fine Arts,

serving as the Academy's Principal from 1950 to 1954.

From 1954 until his retirement, he worked for the City Architect Directorate.

Ejner Larsen & Aksel Bender Madsen

Larsen and Bender Madsen became acquainted at the Royal Danish Academy of Fine Arts. Their acquaintance developed into a lifelong friendship, and in 1947 they began to design together in their spare time, continuing until Larsen's death in 1987. Starting in 1947, they annually exhibited at the Copenhagen Cabinetmakers' Guild Furniture Exhibition together with various other cabinetmakers.

From the mid-50s, they worked closely with cabinetmaker Willy Beck for over 25 years. Together, the duo developed a number of Danish classics - over 300 designs in total - always working in a clean, simple style that produced timeless designs. **The Metropolitan Chair** with saddle leather upholstery from 1959 is seen as the design duo's most important work.

Larsen and Bender Madsen's furniture has been exhibited within Denmark and internationally, including at La Triennale in Milan, Italy, in the USA at the Design in Scandinavia exhibition and The Arts of Denmark exhibition.

Several of the designers' works have been purchased by museums around the world, including the Louisiana Museum of Modern Art in Humlebæk, Denmark and the Metropolitan Museum of Art in New York.

Larsen and Bender Madsen won the Copenhagen Cabinetmakers' Guild Annual Prize in 1956 and 1961, as well as several other awards in furniture and art competitions.

Experience Larsen & Bender Madsen's Metropolitan Chair

Watch the making of the Metropolitan Chair

VARIANTS CHOICES AND DIMENSIONS

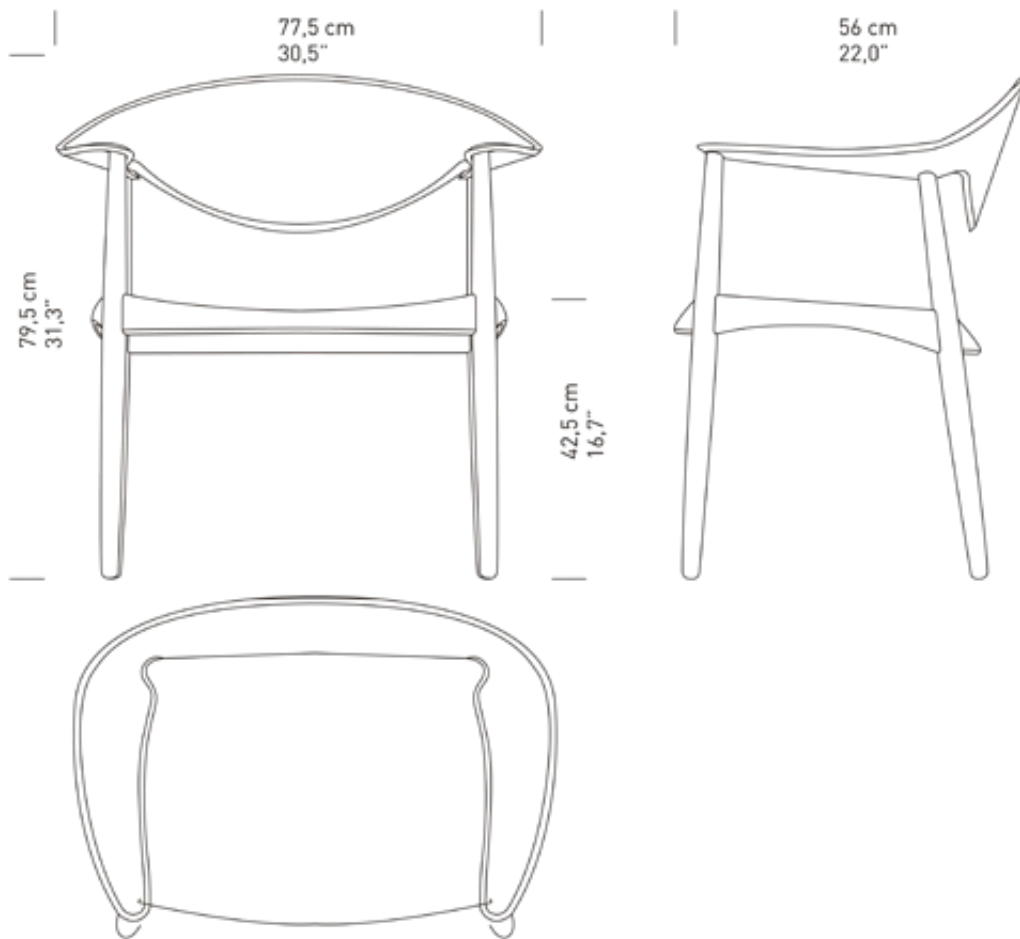

MATERIAL MATRIX

	Lacquer	Oil	White oil	Soap
Oak	●	●	●	●
Walnut	●	●		

ENVIRONMENTAL INFORMATION

Carl Hansen & Søn and sustainability

People's fascination of the combination of good design and wood, as well as other natural materials, is something that transcends time and fashion. At Carl Hansen & Søn, we believe that this fascination helps to explain the great interest in our furniture, and we take very seriously concerns about the sustainability of the natural resources upon which we depend for our products. That is why we strive every day to improve our production methods, logistics and sales efforts in respect of scarce natural resources.

We buy wood only from sustainably managed forests. All sourced wood meets EUTR 2013 regulations, Danish Forest Legislation and current international certifications. Oak, beech and ash come primarily from Danish forests which are managed according to the principles described in

Denmark's National Forest Programme; some of these wood types are also sourced from other similarly managed European forests, or, in the case of walnut and cherry, North American forests.

We use every possible bit of these fine hardwoods in our furniture production. Inevitably, however, there are some scraps, which are then used to produce other products or recycled in district heating plants.

TESTS AND CERTIFICATIONS

All tests and certificates are available on request.

CONTACT INFORMATION

EUROPE

Carl Hansen & Søn A/S

Hylkedamvej 77-79
DK 5591 Gelsted
Denmark

Tel: +45 66 12 14 04
info@carlhansen.com

Carl Hansen & Søn Flagship Store

Bredgade 18, 21 & 23
1260 Copenhagen K
Denmark

Opening Hours:
Monday-Friday: 11.00-18.00
Saturday: 10.00 - 15.00

Phone: +45 64 47 23 60
retail@carlhansen.dk

Carl Hansen & Søn Showroom Oslo

Drammensveien 130 B9
0277 Oslo
Norway

+47 900 77 087
hrs@carlhansen.dk

Carl Hansen & Søn Showroom London

16A Bowling Green Lane
London
EC1R 0BD

United Kingdom

Tel: +44 (0) 20 7632 7587

Mail: ukinfo@carlhansen.com

Carl Hansen & Søn Italy SRL

Showroom Milan

Foro Buonaparte 18/A/ Via Arco 4

20121 Milan

Tel: +39 02 89011837

Area Manager Southern Europe

Ottorino Castegnaro

Tel: +39 340 4266636

Mail: oc@carlhansen.dk

AMERICA

Carl Hansen & Søn, Corp.

251 Park Avenue South

13th Floor

New York, NY 10010

Tel: +1 212 242 6736

Customer Service: Northamerica@carlhansen.com

Contract Sales:

[Contract contact information US](#)

Thomas Vagner, President: tv@carlhansen.com

Angela Patsiopoulos, Director of Retail Sales: ap@carlhansen.com

Carl Hansen & Søn Showroom Los Angeles

8745 Washington Boulevard

Studio B

Culver City, CA 90232

Tel.: + 1 (310) 842-8656

ASIA/PACIFIC

Carl Hansen & Søn Japan K.K.

2F Hills Aoyama, 3-39-9 Jingumae

Shibuya-ku 150-0001

Tokyo, Japan

Tel: +81 3 5413 6771

Fax: +81 3 5413 6772

info@carlhansen.jp

Carl Hansen & Søn Flagship Store Japan

Aoyama Artworks 1/2F
2-5-10 Jingumae
Shibuya-ku, Tokyo, 150-0001
Japan
+81 3 5413 5421

Opening hours

Mon-Fri: 11 am- 8 pm

Sat. Sun. and

National Holidays: 12 a m - 7pm

Carl Hansen & Søn Asia Pacific Limited

16th Floor, 202 Centre
202-204 Des Voeux Road West
Hong Kong

Tel: +852 563 10267

Mail: asiainfo@carlhansen.dk

Carl Hansen & Søn China

570 Yongjia Road, Surpass Court Building 5 Room 501
Xuhui District, Shanghai
China, 200030

Tel: +86 15000390978

Mail: chinainfo@carlhansen.dk