

VELA



VELA-RX MOTORE 220V 500W

Electronic control unit with UP, DOWN and STOP
functions for managing 230 V,
max. 500 W motors via wire and/or radio

INDEX

1 - PRODUCT FEATURES

1.1 - TECHNICAL DATA

1.2 - DESCRIPTION

2 - ELECTRICAL CONNECTIONS

2.1 - CONNECTION DIAGRAM

3 - USE OF THE CONTROL UNIT

3.1 - USE VIA RADIO

3.2 - USE VIA WIRE

4 - CONTROL UNIT SETTINGS

4.1 - CONFIGURATION OF BUTTONS VIA WIRE

4.2 - CONFIGURATION OF MANOEUVRE TIMES

5 - RADIO PROGRAMMING

6 - DELETION OF TRANSMITTERS

WARNINGS

- Installation must be carried out only by qualified technicians in compliance with the electrical and safety standards in force.
- All connections must be made with the power turned off.
- Use suitable cables.
- Do not cut through the aerial (see picture 1.1b)
- A suitably sized disconnection device must be set up on the electric power line that supplies the product.
- Disposal of waste materials must fully respect local standards.

1 PRODUCT FEATURES

1.1 TECHNICAL DATA

Power supply	From the grid 120-240 Vac
Outputs	1 motor powered from the grid: 230V max 500W, 110V max 250W
Num. of programmable transmitters	100
Radio frequency	433.920MHz ISM
Protection rating	IP20
Operating temperature	-20 +55 °C
Dimensions	52x43x21 mm

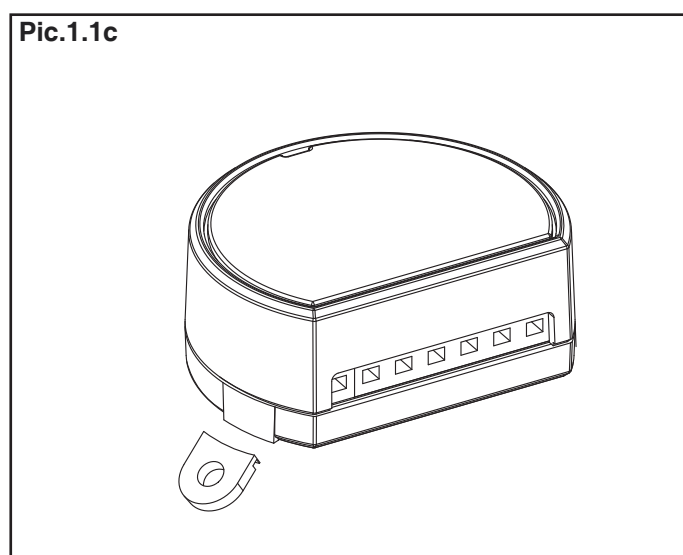
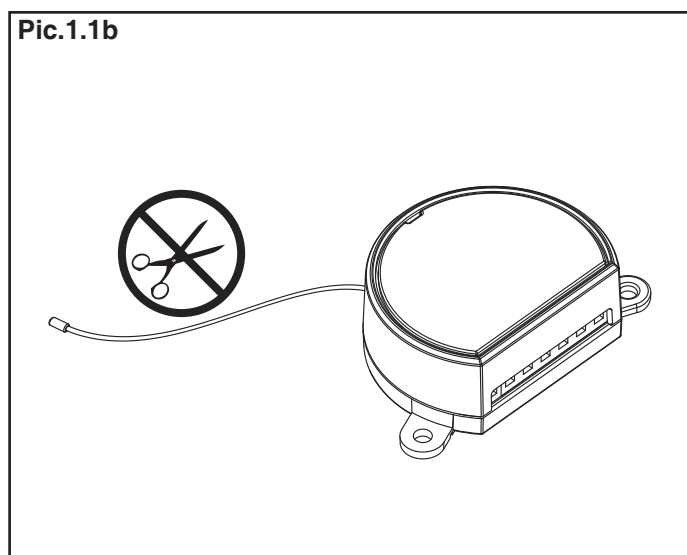
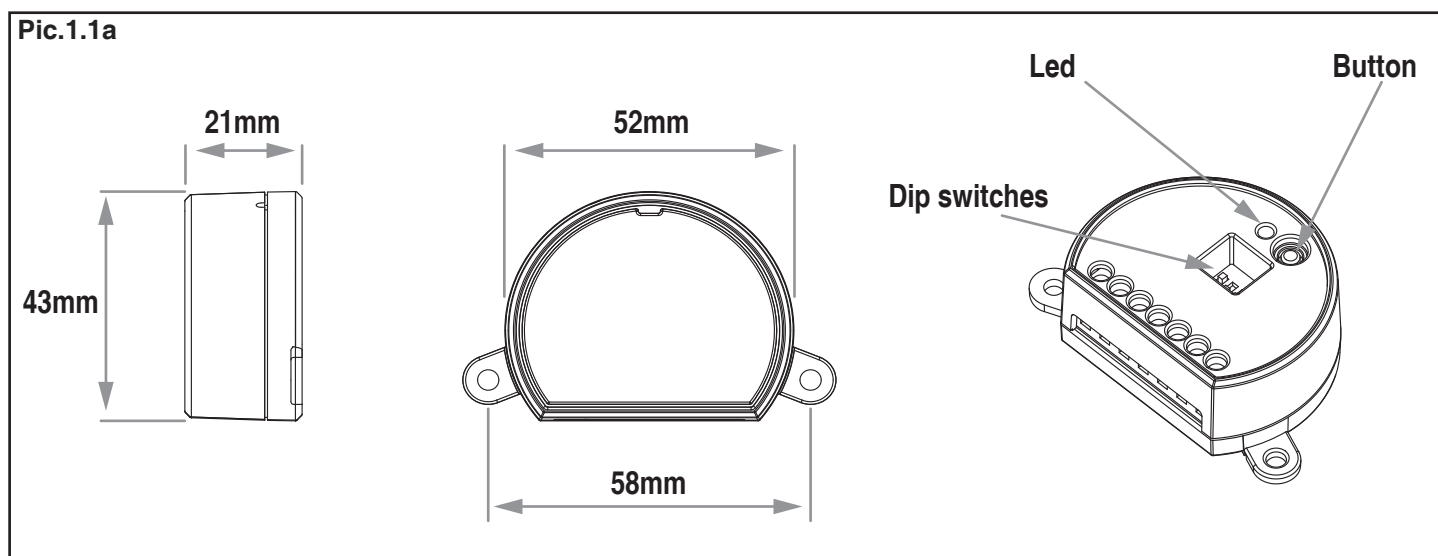

1.2 DESCRIPTION

The product is a control unit to control electrical motors powered from the grid with power of max. 500 W (230 V) or max. 250 W (110 V).

Ideal for activating motorised awnings, shutters and blinds with settable Up-Down-Stop, step and manual modes.

The ISM (industrial, scientific and medical) radio frequency band guarantees a long range, even through walls and ceilings.

Simple programming with dip-switches, reduced dimensions with breakable tabs (pic. 1.1c) for fixing with screws (pic. 1.2a) or for insertion into connection boxes up to 55 mm in diameter (pic. 1.2b, 1.2c and 1.2d).

Pic.1.2a

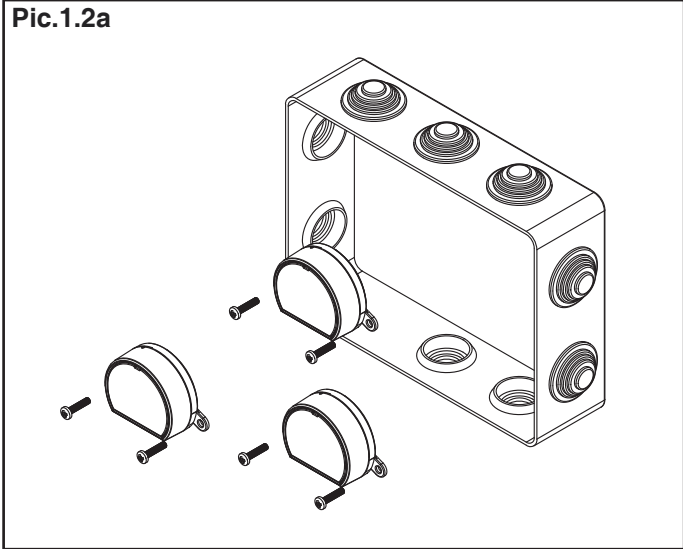

Pic.1.2b

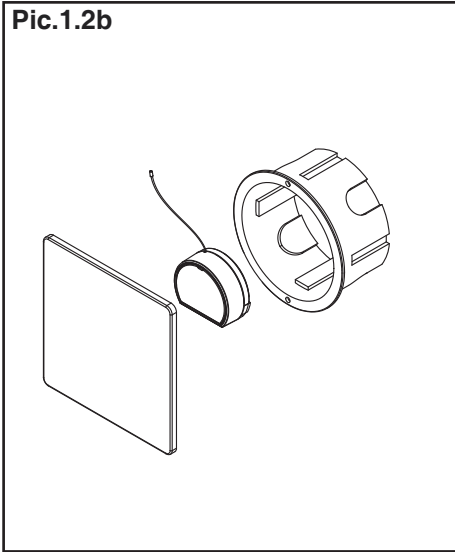

Pic.1.2c

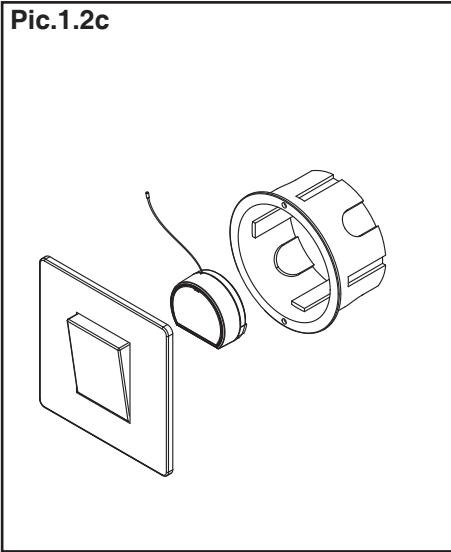

Pic.1.2d

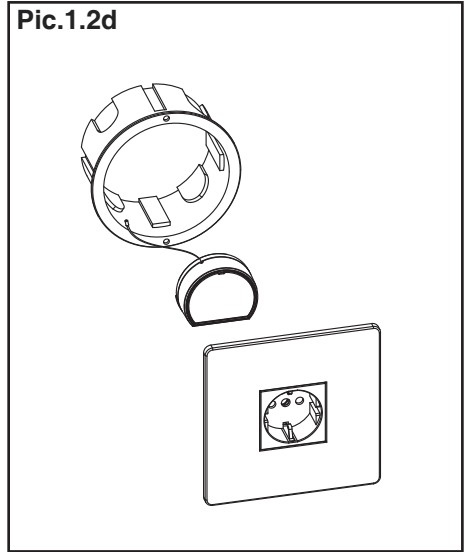

Pic.1.2e

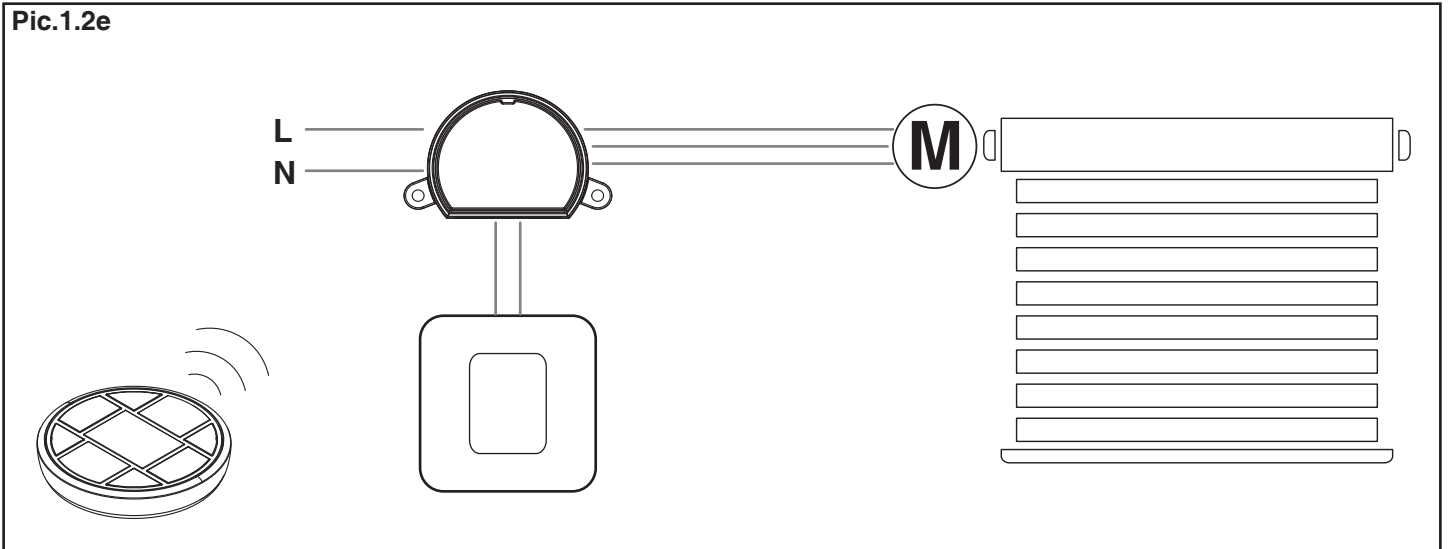

2 ELECTRICAL CONNECTIONS

WARNING: It is possible to connect multiple buttons to the same input with parallel connection.

Pic.2.1

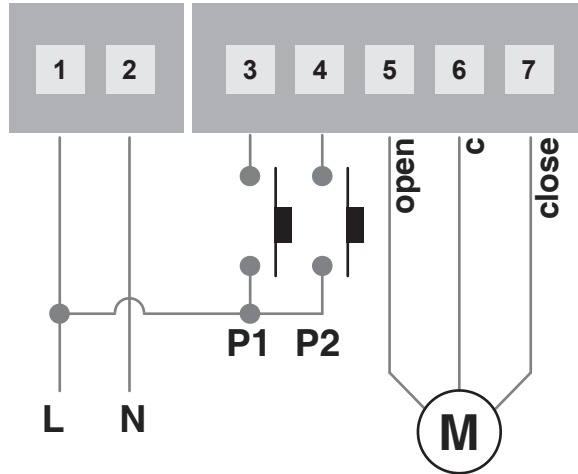

WARNING:

- The control unit is set up to control motors with internal end limit regulation.
 - Buttons must be used for control via wire
 - Multiple buttons or loads can be connected by using parallel cabling.
 - If the condenser is not connected internally to the motor (typical of tubular motors), it is connected between the phases (terminals 4 and 6). Refer to the motor manual
 - It is important to respect the opening and closing phase of the motor to make the commands of the transmitter and the wired inputs in mode 2 synchronise (see paragraph 4.1).
- If the opening phase is not shown in the motor, carry out a test to check which wire it corresponds to.

3 USE OF THE CONTROL UNIT

3.1 USE VIA RADIO

To control the motor via radio you must have compatible transmitters and therefore must carry out the association procedure; see paragraph 5.

The transmitter's command modes depend on the model used. If the transmitter is of a generic type, its operation depends on the way it is programmed (see paragraph 5, table 5.3a).

If the transmitter is multifunctional, refer to the transmitter manual, to the paragraph entitled "commands sent by the transmitter", bearing in mind that it is an "up-down-stop" device.

3.2 USE VIA WIRE

The device is set up to be able to accept commands via wire from buttons in terminals 3 and 4. Should you wish to control the load only via radio, it is not necessary to connect these devices for the control unit to work properly.

Default operation (Key P1 = Key P2):

DIP4 ON, step: with each press the motor will carry out an opening movement, a stop, a closing movement, a stop, in sequence.

DIP4 OFF, manual operation: the motor will carry out its manoeuvres only with the key pressed down.

The motor will carry out an opening manoeuvre in sequence (when the key is released it will carry out a stop) and a closing manoeuvre (when the key is released it will carry out a stop).

4 CONTROL UNIT SETTINGS

4.1 CONFIGURATION OF BUTTONS VIA WIRE

Default: mode 1

This procedure lets you select the function of inputs "P1" (terminal 3) and "P2" (terminal 4). **WARNING:** the connected devices must be buttons.

PROCEDURE:

STEP 1
Position DIPs 1, 2 and 3 to OFF-ON-OFF

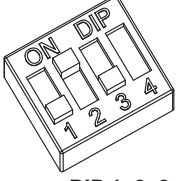

DIP 1, 2, 3=
OFF ON OFF

STEP 2
Press the button on the receiver for a short time.

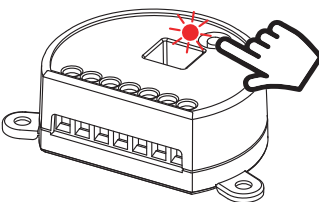

The LED comes on and stays on

SHORT PRESSURE

STEP 3
Press the button on the receiver for a short time

count the number of flashes emitted by the LED:
6 flashes = MODE 1 (P1=P2= pen/stop/close/stop)
3 flashes = MODE 2 (P1= Open/stop P2= Close/stop)

NUMBER OF FLASH	TYPE OF INPUT
3	mono-button
6	bi-button

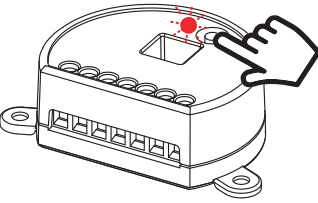

SHORT PRESSURE

STEP 4
To change the setting, repeat the procedure from point 1; the control unit will alternate between 3 and 6 flashes.

CONTROL MODES:

PULSE OPERATION

An action of the motor corresponds to each short pressure of the key

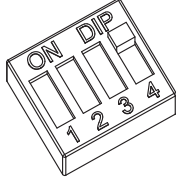

DIP 4 =
ON

MANUAL OPERATION

The movements of the motor occur only with the key pressed down, when it is released the control unit carries out a stop

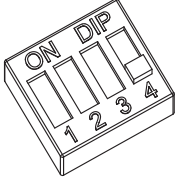

DIP 4 =
OFF

4.2 CONFIGURATION OF MANOEUVRE TIMES

Default: 60 seconds

This procedure is used to set the opening and closing manoeuvre time (maximum time that can be set 3 minutes).

PROCEDURE:

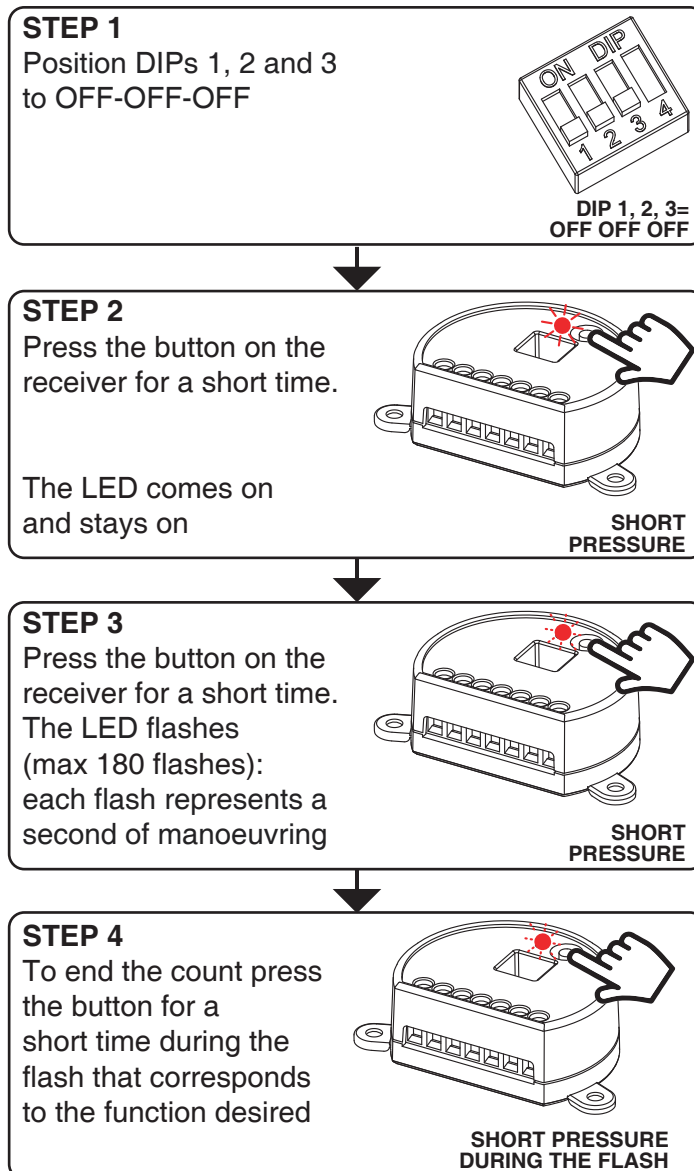

5 - RADIO PROGRAMMING

This procedure lets you programme multifunctional or generic compatible transmitters.

WHICH REMOTE CONTROL DO YOU WANT TO ASSOCIATE WITH THE CONTROL UNIT?

MULTIFUNCTIONAL TRANSMITTERS - MODELS AND CODES



CODE:
BLACK VELA TONDO 30

With multifunctional transmitters the transmitter control modes depend on the model used. Refer to the transmitter manual, to the paragraph entitled "commands sent by the transmitter", bearing in mind that it is a "motor" device.

GENERIC TRANSMITTERS - MODELS AND CODES



CODE:
VELA TX 220V-3V





CODE:
WHITE VELA TONDO 6,
BLACK VELA TONDO 6

With generic transmitters, the transmitter's control modes depend on the function associated with the key during the association procedure (see the following page).

The available function for the key are:

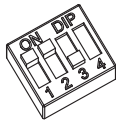
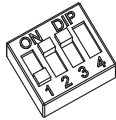
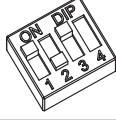
TABLE 5.1A
KEY FUNCTIONS OF THE GENERIC TRANSMITTER

POSITION OF DIP IN "STEP 1b" OF THE PROCEDURE	KEY FUNCTION
 <p>DIP : ON ON OFF</p>	UP / STOP / DOWN / STOP
 <p>DIP : OFF ON ON</p>	UP
 <p>DIP : ON OFF ON</p>	DOWN
 <p>DIP : OFF OFF ON</p>	STOP

PROCEDURE

WHICH TRANSMITTER DO YOU WANT TO PROGRAMME?

MULTIFUNCTION TRANSMITTER
(see models and codes on previous page)

GENERIC TRANSMITTER
(see models and codes on previous page)

STEP 1a

Position DIPs 1, 2 and 3 to ON-ON-ON

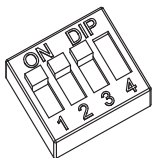

DIP 1, 2, 3 =
ON ON ON

STEP 1b

Positions DIPs 1, 2 and 3 according to the function you want to associate with the remote control key. See table 5.1 on the previous page.

STEP 2

Press the button on the receiver for a short time.

The LED comes on and stays on.

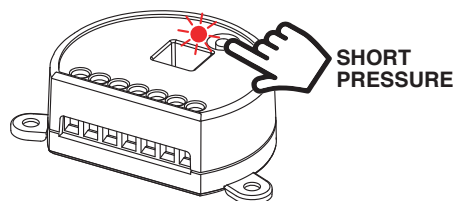

STEP 3

Make a transmission with the transmitter to be saved (see transmitter manual, paragraph entitled "transmitter programming").

The LED on the receiver flashes 3 times to signal that it has been received.



MAKE A TRANSMISSION
WITH THE TRANSMITTER

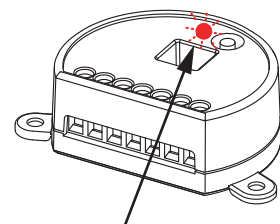

THE LED FLASHES 3 TIMES

STEP 4

The control unit listens for 30 seconds in case you want to add other transmitters.

To immediately exit the procedure give a short pressure on the button on the receiver.

The LED turns off

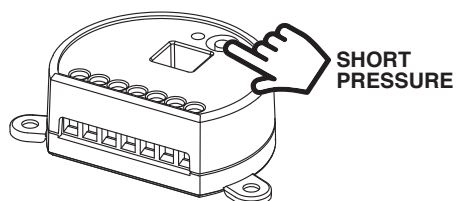

6 - DELETION OF TRANSMITTERS

These procedures let you delete from the memory transmitters that have already been programmed.

6.1 DELETION OF SINGLE TRANSMITTER:

STEP 1

Hold the receiver button down for 8 seconds.

The LED begins to flash

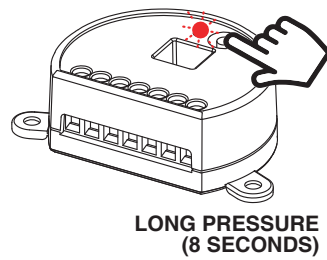

STEP 2

Make a transmission with the transmitter that you want to delete.

The LED flashes quickly and turns off.



MAKE A TRANSMISSION
WITH THE TRANSMITTER

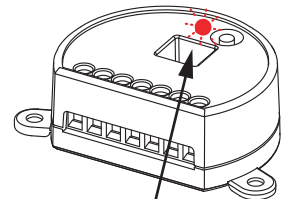

LED FLASHES QUICKLY

6.2 DELETION OF ALL THE SAVED TRANSMITTERS

STEP 1

Hold the receiver button down for 8 seconds.

The LED begins to flash.

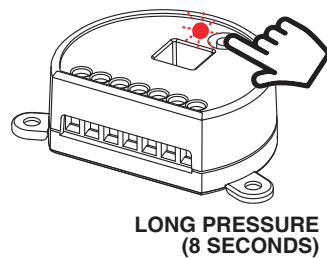

STEP 2

Press the button on the receiver for a short time.

The LED starts flashing quickly and turns off

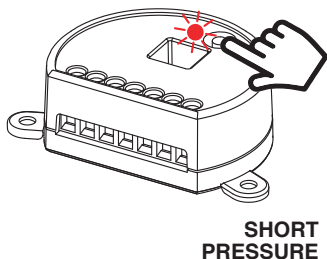



Sede legale e operativa / Headquarters:

Via del Lavoro, 10
30030 Salzano (VE) - Italy
Tel. +39.041.5740374
Fax +39.041.5740388
info@venitem.com
www.venitem.com

AZIENDA CERTIFICATA



DESIGN E
PRODUZIONE
IN ITALIA 

ITALIAN DESIGN AND PRODUCTION

V1.0