

em-trak R100

AIS Dual Channel Receiver

HIGH PERFORMANCE
MARITIME
PRODUCTS



Product Manual

em-trak 
High Performance Maritime Products

www.em-trak.com

201-0138:1

Contents

1 - Notices	1
1.1 - Safety warnings	1
1.2 - General notices	1
2 - About your AIS receiver	3
2.1 - About AIS	3
2.2 - Static and dynamic vessel data	3
2.3 - What's in the box?	5
3 - Installation	7
3.1 - Preparing for installation	7
3.2 - Installation procedures	10
4 - Operation	17
4.1 - Using the AIS receiver	17
4.2 - Indicator functions	17
5 - Troubleshooting	18
6 - Specifications	19

1 Notices



When reading this manual please pay attention to the warnings marked with the warning triangle shown on the left. These are important messages for safety, installation and usage of the product.

1.1 Safety warnings



This equipment must be installed in accordance with the instructions provided in this manual.



The em-trak R100 is an aid to navigation and must not be relied upon to provide accurate navigation information. AIS is not a replacement for vigilant human lookouts and other navigation aids such as Radar. The performance of the R100 may be seriously impaired if not installed as instructed in the user manual, or due to other factors such as weather and or nearby transmitting devices. Compatibility with other systems may vary and is reliant on the third party systems recognising the standard outputs from the R100. em-trak reserves the right to update and change these specifications at any time and without notice.



Do not install this equipment in a flammable atmosphere such as in an engine room or near to fuel tanks.

1.2 General notices

Compass safe distance

The compass safe distance of this unit is 0.2m or greater for 0.3° deviation.

RF emissions notice

Caution: The AIS receiver generates and radiates radio frequency electromagnetic energy. This equipment must be installed and operated according to the instructions contained in this manual. Failure to do so can result in personal injury and / or AIS receiver malfunction.

Caution: The antenna should not be co-located or operated in conjunction with any other transmitting antenna. The required antenna impedance is 50Ohms.

Warranty

This product is supplied with standard warranty as defined in the Warranty statement supplied with the product.



Any attempt to tamper with or damage this product will invalidate the warranty.

Disposal of this product and packaging

Please dispose of the AIS receiver in accordance with the European WEEE Directive or with the applicable local regulations for disposal of electrical equipment.

Every effort has been made to ensure the packaging for this product is recyclable. Please dispose of the packaging in an environmentally friendly manner.

Accuracy of this manual

The AIS receiver may be upgraded from time to time and future versions of the AIS receiver may therefore not correspond exactly with this manual. The manufacturer of this product disclaims any liability for consequences arising from omissions or inaccuracies in this manual and any other documentation provided with this product.

2 About your AIS receiver

2.1 About AIS

The marine Automatic Identification System (AIS) is a location and vessel information reporting system. It allows vessels equipped with AIS to automatically and dynamically share and regularly update their position, speed, course and other information such as vessel identity with similarly equipped vessels. Position is derived from the Global Positioning System (GPS) and communication between vessels is by Very High Frequency (VHF) digital transmissions.

There are a number of types of AIS device as follows:

- **Class A transceivers.** These are similar to class B transceivers, but are designed to be fitted to large vessels such as cargo ships and large passenger vessels. Class A transceivers transmit at a higher VHF signal power than class B transceivers and therefore can be received by more distant vessels, and also transmit more frequently. Class A transceivers are mandatory on all vessels over 300 gross tonnes on international voyages and certain types of passenger vessels under the SOLAS mandate.
- **Class B transceivers.** Similar to class A transceivers in many ways, but are normally lower cost due to the less stringent performance requirements. Class B transceivers transmit at a lower power and at a lower reporting rate than class A transceivers.
- **AIS base stations.** AIS base stations are used by Vessel Traffic Systems to monitor and control the transmissions of AIS transceivers.
- **Aids to Navigation (AtoN) transceivers.** AtoNs are transceivers mounted on buoys or other hazards to shipping which transmit details of their location to the surrounding vessels.
- **AIS receivers.** AIS receivers will generally receive transmissions from class A transceivers, class B transceivers, AtoNs and AIS base stations but do not transmit any information about the vessel on which they are installed.

The em-trak R100 is a dual channel AIS receiver.

2.2 Static and dynamic vessel data

There are two categories of information transmitted by an AIS transceiver: static and dynamic data.

The vessel's dynamic data, which includes location, speed over ground (SOG) and course over ground (COG), is calculated automatically using the internal GPS receiver.

Static data is information about the vessel which must be programmed into an AIS transceiver. This includes:

- Maritime Mobile Service Identity (MMSI)
- Vessel name
- Vessel call sign (if available)
- Vessel type
- Vessel dimensions

2.3 What's in the box?

Figure 1 shows the items included with your AIS receiver purchase. The following sections give a brief overview of each item. Please ensure all items are present and if any of the items are not present contact your dealer.

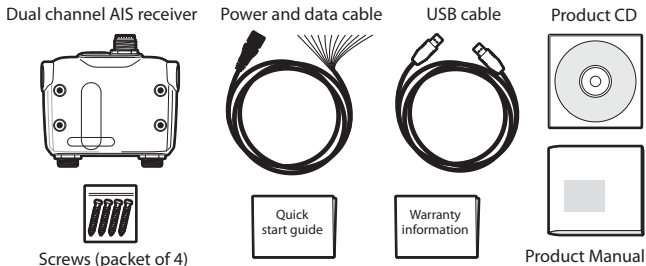

Figure 1 Items included in the product

- **Support tools CD**

The CD supplied with the package contains the following:

- USB drivers required to connect to the AIS receiver via USB.
- Alternative language versions of this manual.
- Other application software may be included on the CD depending on the version of product you have purchased. For details of AIS application software please contact emtrak via the details printed on the back of this manual.

- **Quick start guide**

The quick start guide gives a handy one page reference for the installation process.

- **Product manual**

This document is the product manual and should be read thoroughly prior to any attempt to install or use the AIS receiver.

- **Fixing screws**

Two fixing screws are provided with the product for mounting of the AIS receiver. Please refer to section 3.2 for details of how to mount the AIS receiver.

- **Accessory cable**

The accessory cable provides connections to the AIS receiver for power supply and NMEA0183 connections.

- **USB cable**

The USB cable can be used to connect the AIS receiver to a PC.

- **AIS receiver unit**

Figure 2 shows an overview of the AIS receiver unit.

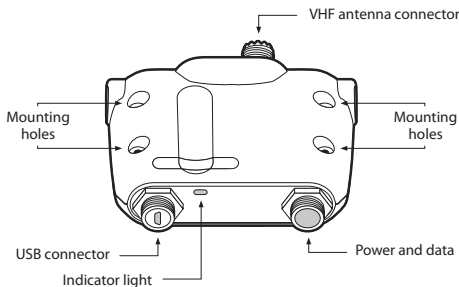

Figure 2 AIS receiver overview

3 Installation

3.1 Preparing for installation

Figure 3 shows a typical installation configuration for the AIS receiver. Please take the time to familiarise yourself with the system elements and their connections prior to attempting installation.

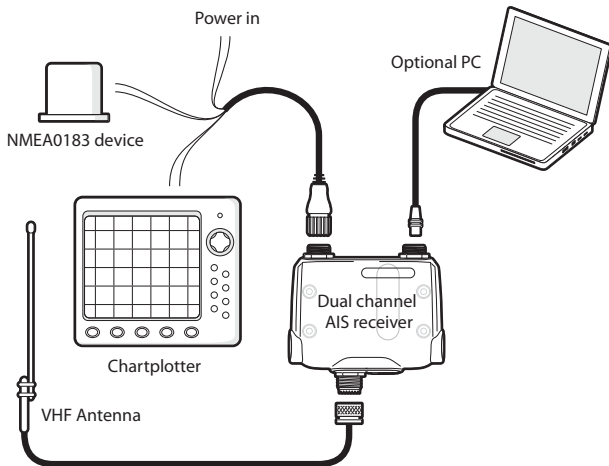

Figure 3 Typical installation configuration

In addition to the items provided with your AIS receiver the following items will be required for installation:

VHF antenna

Connection to a suitable VHF antenna will be required for the AIS receiver to operate. A standard marine band VHF antenna such as that used with VHF voice radios will be sufficient. Please take note of the warnings in section 1 regarding the use of antennas.

Alternatively, if you wish to use an existing VHF antenna, antenna splitter products are available which allow the existing antenna to be used with two radio devices, such as a VHF voice radio and the AIS receiver.

Antenna cables

Please check that the VHF antenna you intend to use has sufficient cable to reach between the VHF antenna and the AIS receiver unit. If it is not sufficient you will need an extension cable. Please contact your dealer for details of suitable products. For reference the VHF antenna connector type on the AIS receiver unit is SO239, and is intended to mate with a PL259 connector.

Power and data cables

The AIS receiver unit is supplied with a two metre long power and data accessory cable. If you require longer cables to reach your power supply, please ensure the cables are capable of carrying an average current of up to 200mA. Means of connecting the cables together will also be required. The use of Scotchlok™ connectors is recommended for this purpose.

Chart plotter

To display received AIS position reports as other vessels on your chart plotter, you will need to connect your AIS receiver to your chart plotter. Please refer to the user manual supplied with your chart plotter for details of how to connect and configure your chart plotter for use with AIS devices. For general guidance your chart plotter should be configured to accept NMEA data at 38400 baud (sometimes referred to as 'NMEA HS' in the plotter configuration menu). You may also need to enable the display of AIS targets in the chart options.

Step 8 - USB Connection (optional)

The AIS receiver is supplied with a USB port for connection to a PC. The USB connector can be connected directly to the USB port on the PC via the supplied USB cable. To enable connection

of the AIS receiver to a PC the USB drivers, supplied on the product CD, must be installed on the PC.

Prior to connecting the AIS to a PC the USB drivers must first be installed. To install the drivers please follows the steps below:

1. Insert the product CD into the PC and navigate to the USB drivers folder.
2. Double click on the setup.exe file to launch the installer.
3. Follow the on screen installation instructions to complete installation.
4. Once installed the AIS receiver can be connected to the PC. The USB drivers will be installed automatically and the AIS will appear as a new COM port device.
5. Select the AIS COM port and a baud rate of 38,400 in PC based navigation software to make use of the AIS data.



If the USB connection is removed from the PC during use you must reset the connection before further use. to reset the connection, disconnect then reapply power to the AIS before closing and relaunching any PC applications using the USB connection. Finally, reconnect the USB cable between the PC and the AIS receiver.

If required, the unit can be powered via the USB connection directly from the PC thus avoiding the need for a separate power supply connection. If this option is selected the power connection on the accessory cable should insulated to avoid being short circuited.

3.2 Installation procedures

Before beginning installation of your AIS receiver, please ensure you have the necessary additional items as detailed in section 3.1. It is strongly recommended that you read all of the instructions in this manual prior to installation.

If after reading this manual you are unsure about any element of the installation process please contact your dealer for advice.

The following sections explain the installation process step by step for each of the main elements of the system.

Step 1 - Installing the AIS receiver

Please note the following guidelines when selecting a location for your AIS receiver:

- The AIS receiver must be fitted in a location where it is at least 0.5m from a compass.
- There should be adequate space around the AIS receiver for routing of cables. See Figure 4 for details of the AIS receiver dimensions.
- The ambient temperature around the AIS receiver should be maintained between -10°C and +55°C.
- The AIS receiver should not be located in a flammable or hazardous atmosphere such as in an engine room or near to fuel tanks.
- The AIS receiver is not designed to be waterproof and it is therefore not recommended that the AIS receiver be subjected to spray or submersion.
- It is recommended that the AIS receiver is installed in a 'below decks' environment.
- It is acceptable to mount the AIS receiver either vertically or horizontally.
- The product is supplied with four self tapping screws for attachment of the AIS receiver to a suitable surface. Please refer to Figure 4 for guidance.
- The AIS receiver should be mounted in a location where the indicator is readily visible as this provides important information on the status of the AIS receiver.

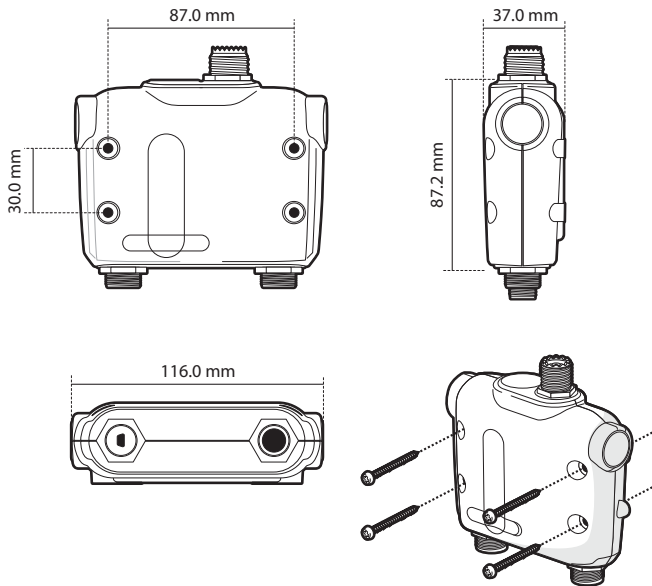
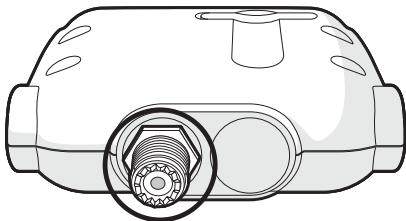

Figure 4 AIS receiver dimensions and mounting

Step 2 - Connecting the VHF antenna

Route the cable from the VHF antenna to the AIS receiver and connect to the VHF connector on the AIS receiver as shown in Figure 5.

A standard marine band VHF antenna or AIS antenna should be used with the AIS receiver. The connector type on the AIS receiver is SO239. Your chosen VHF antenna requires a PL259 connector to mate with this. If your VHF antenna does not use this type of connector please contact your dealer for details of available adaptors.



VHF Antenna

Figure 5 Position of the VHF antenna connector

Step 3 - Connecting to a chart plotter or other NMEA0183 device

The NMEA0183 data port provides the connection to your chart plotter and consists of four wires colour coded as shown in the table below and in Figure 6. Connect the two 'Transmit' wires to the appropriate connections on your chart plotter. Please refer to your chart plotter manual for more information.

The NMEA0183 data port output operates at a baud rate of 38400 baud. Please ensure your chart plotter is configured to receive data from the AIS receiver via its NMEA0183 port at 38400 baud.

Please note that the 'Receive' connections should not normally be connected to your chart plotter as it is not normal for the receiver to receive data from the chart plotter.

NMEA0183 function	Wire colour
Transmit + (Output)	Brown
Transmit - (Output)	Blue
Receive + (Input)	White
Receive - (Input)	Green

Step 4 - Connecting an optional NMEA0183 device

If you wish to connect a NMEA0183 device (such as a heading sensor) to your chart plotter, but your chart plotter only has a single NMEA0183 input, it is possible to use the AIS receiver's NMEA0183 multiplexing feature to connect both devices to the chart plotter.

To multiplex your NMEA0183 device data via the AIS receiver simply connect the device's NMEA0183 output to the receive + and receive - terminals as defined in the table above. The NMEA0183 input baud rate is 4800 baud. Please ensure your NMEA0183 device operates at 4800 baud.

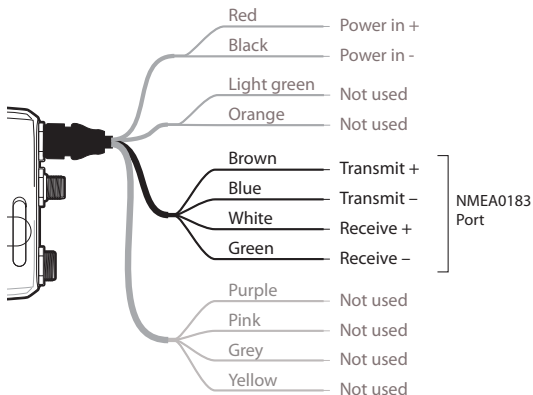

Figure 6 Connecting to the NMEA0183 data port

Connection to a PC

The AIS receiver is supplied with a USB connector for connection to a PC via the USB cable provided. If your PC requires USB drivers to operate with the AIS receiver these can be found on the CD provided with the product.

The AIS receiver can be powered via USB removing the need to have a separate power supply connection to the unit. No additional actions need to be taken other than to connect the USB cable as described. It is possible to connect both USB and an external power supply as described in step 4 below. In this instance the unit will automatically takes its power from the external supply.

When inserting the USB connector into a PC for the first time, you are likely to be prompted to select the drivers for the USB device. Insert the CD provided with the product into the PC and

select 'Search for drivers on this computer'. Your PC should find the drivers located on the CD and install them on the PC.

Please note: If you connect the USB connector to an alternative port on your PC this procedure may be repeated.

The AIS receiver will appear as an additional COM port on your PC. This COM port should be selected as the AIS data source in charting applications. The port operates at 38400 baud.

Step 4 - Connecting to a power supply

The AIS receiver requires a 12V or 24V power supply typically provided by the vessel's battery.

It is recommended that crimped and soldered lugs are used to connect the AIS receiver to the power source.

It is recommended that the power supply is connected via a suitable circuit breaker and/or 1A fuse block.

1. Connect the red wire to the power supply positive terminal.
2. Connect the black wire to the supply negative terminal.

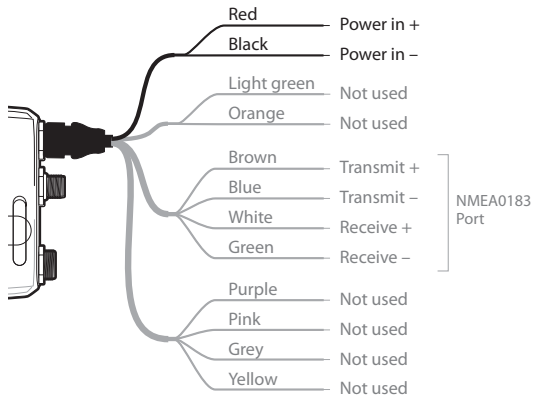

Figure 7 Connecting the power supply

4 Operation

4.1 Using the AIS receiver

Once the unit has been installed it is ready for use. Providing other vessels with AIS transceivers installed are within radio range of your vessel you should see their details appear on your chart plotter or PC.

Specific details of how to configure your chart plotter to make use of the AIS receiver features will be given in your chart plotter manual. If you are using charting software running on a PC, please refer to the instructions provided with your chart plotting software for details of how to configure it to display AIS information.

4.2 Indicator functions

The AIS receiver includes a green indicator light as shown in Figure 8. The state of the indicator provides information regarding the status of the AIS receiver. The status indicator will illuminate when power is applied to the unit and it is running in normal mode. The brightness of the indicator will decrease on receipt of AIS messages.

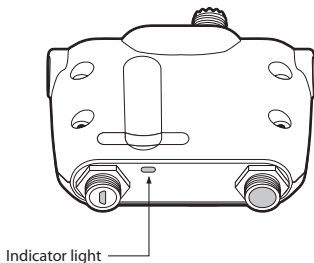

Figure 8 Indicator location on the AIS receiver unit

5 Troubleshooting

Issue	Possible cause and remedy
No data is being received by the chart plotter	<ul style="list-style-type: none"> • Check that the power supply is connected correctly, or if the unit is powered via USB check the PC is powered on. • Check that the connections to the chart plotter are correct. • Check that the VHF antenna is correctly connected in accordance with the instructions in the manual
The indicator is not illuminated	<ul style="list-style-type: none"> • Check that the power supply is connected correctly, or if the unit is powered via USB check the PC is powered on.
The indicator is flashing but AIS targets are not displayed on the chart plotter	<ul style="list-style-type: none"> • Check the chart plotter NMEA port configuration is set to receive AIS data • Check the chart plotter display settings are configured to show AIS targets • Consult the chart plotter manufacturers documentation
The indicator is illuminated but not flashing to indicate receipt of AIS data	<ul style="list-style-type: none"> • Check there are vessels equipped with AIS transceivers in your area • Check the VHF antenna is correctly installed and connected

If the guidance given in the table above does not rectify the problem you are experiencing, please contact your dealer for further assistance.

6 Specifications

Parameter	Value
Dimensions	116 x 115 x 37.0 mm (L x W x H)
Weight	120g (AIS receiver unit only)
Power	DC (9.6V - 31.2V)
	Average power consumption 90mA at 12VDC
	Peak current rating 200mA
Electrical Interfaces	USB 2.0, 38400 baud bi-directional
	NMEA0183 38400 baud (output) 4800 baud (input)
Connectors	VHF antenna connector type: SO239 50Ω
	USB
	12 way connector for NMEA0183 / Power
Dual channel receiver	Fixed frequency reception at 161.975MHz and 162.025MHz
Channel Bandwidth	25kHz
Receiver Sensitivity	Better than -107dBm at 20% Packet Error Rate
Environmental	Operating temperature: -25°C to +55°C
Ingress Protection rating	IPx2



High Performance Maritime Products

www.em-trak.com

The em-trak R100 is an aid to navigation and must not be relied upon to provide accurate navigation information. AIS is not a replacement for vigilant human lookouts and other navigation aids such as Radar. The performance of the R100 may be seriously impaired if not installed as instructed in the user manual, or due to other factors such as weather and or nearby transmitting devices. Compatibility with other systems may vary and is reliant on the third party systems recognising the standard outputs from the R100. em-trak reserves the right to update and change these specifications at any time and without notice.

Head Office:

em-trak Marine Electronics Limited
Forum 3,
Parkway, Solent Business Park,
Whiteley, Fareham,
Southampton PO15 7FH
United Kingdom

T +44 (0)1489 611662 | F +44 (0)1489 611612
enquiries@em-trak.com

Regional Office:

em-trak Marine Electronics Limited
470 Atlantic Avenue,
4th floor,
Boston MA 02210
USA

T +1 617 273 8395 | F +1 617 273 8001
enquiries@em-trak.com