



CUSTOMER MANUAL

Front Hub Motor System for Roller Brake

Original instruction manual

Read carefully before use. Keep for later reference.

BF-CM-S-F02-EN-PRINT A/0 , June 2017

CONTENT

1 Important Notice	2
2 Introduction	3
2.1 Overview.....	3
3 Safety Instructions	4
3.1 General information.....	4
3.2 For your safety.....	4
3.3 Installation and Maintenance.....	5
3.4 Safety Precautions.....	5
3.5 Quick Start.....	6
3.6 Before the first ride.....	6
3.7 Before each ride.....	6
3.8 Legal Regulations.....	7
4 Electronic Components	8
4.1 Important Instructions.....	8
4.2 Batteries.....	9
4.2.1 User Instructions.....	9
4.2.2 Notification.....	10
4.2.3 Caution.....	11
4.2.4 Specifications.....	12
4.3 Charger.....	12
4.4 Hub motor.....	13
5 Operation	14
5.1 Installing the battery.....	14
5.2 Removing the battery.....	14
5.3 LED capacity and state of charge indication.....	14
5.4 Charging the battery.....	15
5.5 Switching the electrical system on and off.....	17
6 Displays and Settings	18
6.1 Display C13.UART.....	18
6.2 Specifications and Parameters.....	18
6.3 Functional Overview.....	18
6.4 Items to be shown on the Display.....	18
6.5 Usual operation.....	19
6.5.1 Power ON/OFF.....	19
6.5.2 Push-assistance.....	19
6.5.3 Light ON/OFF button.....	20
6.5.4 PAS level selection.....	20
6.5.5 Clearing your Trip Distance.....	20
6.5.6 Clearing the Max speed,Average Speed and trip time.....	20
6.5.7 Battery Indicator.....	20
6.6 Primary Settings.....	20
6.6.1 Unit Conversion "km / mile".....	20
6.6.2 Backlight Contrast Settings.....	21
6.6.3 Automatic Power-Off settings.....	21
6.6.4 Error Code Indication.....	22
6.6.5 Error Code Review.....	22
6.6.6 Exit settings.....	22
6.7 Error code definition.....	23
7 Maintenance and repairs	24
7.1 Installation and removal of the front wheel with motor.....	24
7.2 Storing the battery.....	25
7.3 Battery wear.....	26
8 Customer service	27
9 Transporting the Pedelec	28
9.1 By car.....	28
9.2 By public transport.....	28
9.3 By airplane.....	28
10 Disposal considerations	29
11 Specifications	30
12 After-Sales and Warranty Policy	32
Imprint.....	33

1 IMPORTANT NOTICE

This operating manual contains various points and pointers, providing important information about your new pedelec and how to use it, referring to possible damage to property and the environment, and warning against potential falls and serious damage, including physical injury. It is also essential that you comply with the correct torque in order to prevent components from coming loose or breaking. Make sure to read all the documentation supplied.

- This symbol signifies a risk that the danger described may occur.
- Warning texts are always displayed against a gray background.

The warnings break down as follows:



Information: This symbol provides information about how to use the product or highlights specific parts of the operating manual that are particularly important.



Warning: This symbol is used to warn users against improper use that could result in damage to property or the environment.



Danger: This symbol indicates possible dangers to your health and/or even life that may arise if specific actions are not undertaken or corresponding regulations adhered to.



Important bolted connection! Please adhere to the exact recommended torque when tightening this connection. The correct mounting torque is either displayed on the component or listed in the "Bolted connections" section (page 29). A torque wrench must be used to achieve the precise torque prescribed. If you do not own a torque wrench, then you should leave this work up to a specialist retailer. Parts connected using an incorrect torque may fall off or break. This can result in serious accidents.



Operating Instructions. Make sure to read all the installation manuals delivered with the product. If you have doubts concerning any part of the manual, do not install the product yourself. Please consult the local sales office or a pedelec dealer for help.

2 INTRODUCTION

This part of the operating instructions gives you specific information on how to handle the electrical drive unit components and how to drive a Pedelec. For general information, e. g. for pedelec technology, please refer to the enclosed instructions.

Before getting started, carefully read these operating instructions and the general pedelec operating instructions. The manufacturer accepts no liability for damages resulting from non-compliance with these instructions. Your Pedelec must only be used in accordance with its intended use. This is described in the pedelec technology manual.



Any other use may lead to technical failures and accidents. Liability for defects and warranty will be void in case of improper use.

2.1 Overview

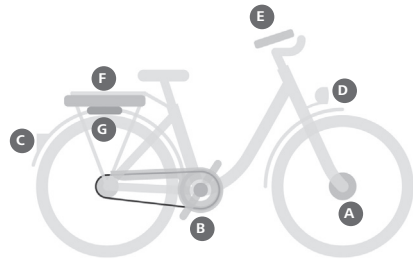

- A. Hub motor
- B. PAS sensor
- C. Rear lamp
- D. Front lamp
- E. Display HMI
- F. Battery
- G. Controller



3 SAFETY INSTRUCTIONS

3.1 General information

 Please ensure you read the chapters “Before the first ride” and “Before each ride” before using the pedelec for the first time.

- If you lend your pedelec to a third party, please give them this operating manual along with the pedelec.
- Check that all quick releases are safe and secure every time you ride, and after your pedelec has been left unused, even for a short period of time. Regularly check that all bolts and components are secure.
- Never ride with your hands off the handle-bars, except when signaling a change of direction.

 When using this product, be sure to follow the instructions given in the user manual.

- It is recommended that you only use genuine BAFANG parts.
- The pedelec may suddenly fall over and serious injury may occur if nuts and bolts are left loosened, or the product is damaged or improperly adjusted.
- When performing maintenance operations (replacing parts, for example), be sure to wear goggles to protect your eyes.
- Please refer to the manuals provided along with the product for information uncovered by this manual.
- After reading the user manual carefully, keep it in a safe place for later reference.

3.2 For your safety

 Always apply the Pedelec’s brakes before placing your foot on the pedal. The motor will drive forward as soon as you push down the pedal. This force may be unfamiliar and can lead to falls, danger or even traffic accidents, which could result in injury.

- Do not pay too much attention to the cycle display while riding, otherwise you may fall off the pedelec.
- Check that the wheels are securely attached to the pedelec before you start riding. If the wheels are not securely installed, the pedelec may fall over and serious injury may result.
- When riding a pedal-assisted electric pedelec, make sure that you are fully familiar with the starting characteristics of the pedelec before riding it. If the pedelec starts off suddenly, accidents may occur.
- Make sure the pedelec's lights are on before riding at night.
- It is vital that all bolted connections on the pedelec have the correct torque in order to ensure that they are secure. An incorrect torque can damage the screw, nut or component. Always use a torque spanner to tighten screw joints. You are not able to correctly tighten these bolted connections without this specialist tool!

3.3 Installation and Maintenance



It is vital that all bolted connections on the pedelec have the correct torque in order to ensure that they are secure. An incorrect torque can damage the screw, nut or component. Always use a torque spanner to tighten screw joints. You are not able to correctly tighten these bolted connections without this specialist tool!



Before performing any kind of work on your Pedelec, turn off the electric motor unit and remove the battery. Not doing so may result in serious injury and/or electric shock.



The frequency of maintenance will vary depending on riding conditions. Periodically clean the chain using an appropriate chain cleaner. Do not use alkaline or acidic cleaning agents to remove rust under any circumstances. If such cleaning agents are used, they may damage the chain and serious injury may result.

3.4 Safety Precautions

- Please follow the instructions given in the user manuals for your riding safety.
- Regularly examine the battery and the charger for damage, especially the cable, plug and casing. If the battery or charger is damaged, it must not be used until it has been repaired.
- Please follow the guidance given by the safety supervisor or the instructions indicated in the manual when using the product. This product is not intended for use by persons (including children) with reduced physical, sensory or mental capabilities, or lacking the required experience and knowledge, unless supervised or having received instructions concerning use of the product by a person responsible for their safety.
- Do not allow children to play near the product.
- Should you encounter any errors or problems, consult your nearest dealer.
- Do not modify the system yourself. Doing so may be considered illegal or cause the system to malfunction.
- For information on product installation and adjustments, please consult with your dealer.
- The product is designed to be fully water-proof so as to withstand wet weather riding conditions. However, do not deliberately immerse it in water.
- Do not clean the pedelec using a high-pressure cleaner. If water gets into any of the components, operating problems or rusting may result.
- When shipping the product on a high-speed vehicle exposed to rain, remove the battery and put it in a safe place to stop it from getting wet.
- Handle the product carefully, and avoid subjecting it to any strong impacts.
- Key important information may also be found on the product labels.
- When buying a spare key for the battery, be sure to provide the number on the battery key. Please keep the number in your mind or your notebook.
- Use a wrung-out damp cloth to clean the battery casing.
- For any questions regarding maintenance and use of the product, please contact the dealer where you bought the product.

- Natural wear and tear due to normal use and aging is not within our scope of our quality warranty.
- Please contact your dealer for software updates (if applicable).
- Please get to know the pedelec on a safe piece of land before setting off on your first ride!

3.5 Quick Start



In this section, you will find important information and instructions that will enable you to safely use your Pedelec as quickly as possible.

- Read all safety instructions.
- Fully charge the battery pack.
- If necessary: Insert the battery.
- Lock the battery.
- Activate the system using the LED button on the battery.
- Press the “⏻” button on the display: the system will turn ON.
- Select the support level via the control unit.

→ **The Pedelec is now ready for operation.**

3.6 Before the first ride



Practice operating and riding your Pedelec in a calm and safe place before you take to public roads.



Please also consult the additional operating manuals, issued by the individual component manufacturers and which were supplied with your pedelec or are available online. Your specialist pedelec retailer will be happy to answer any further questions you may have after reading this manual.

Please ensure that your pedelec is ready for use and is adjusted to your body:

- Set the position and fixture of the seat and handlebars.
- Check the assembly and settings of the brakes.
- Secure the wheels into the frame and fork.
- Charge the battery until it is fully charged.
- Ensure that the battery is sitting securely in its place.

3.7 Before each ride



If you are unsure as to whether your pedelec is in sound technical condition, take it to a specialist retailer to be checked instead of riding it. If you are unsure as to whether your pedelec is in sound technical condition, take it to a specialist retailer to be checked instead of riding it.

The frame, fork, suspension components and other parts relevant to your safety such as brakes and wheels are subject to heavy wear, which can impact the operating safety of these parts.

If you use parts for longer than their intended lifetime, these can fail without warning, which can in turn lead to falls and serious injury.

Before every ride, please check that:

- The lights and bell are working and are safely secured.
- The brakes are working safely and are properly secured.
- The cables and fittings are not leaking if you have a model with hydraulic brakes.
- The tires are free of foreign objects and damage, and the rims are not damaged and run true, particularly after riding off-road.
- The tires have a sufficient tread depth.
- The suspension components are working properly and are safely secured.
- All bolts, nuts and quick releases are tightly fastened.
- There are no deformations or cracks in the frame and fork.
- The handlebars, stem, seat post and seat are all correctly and securely fastened and are set in the right position.
- The seat post and seat are secure Try turning the seat or pulling it upwards or downwards. They should not move.
- If you are using clipless/magnetic pedals, please check that they are working properly. The pedals should release easily and smoothly.
- Make sure that the battery is sitting securely in its place.
- Make sure that the battery is sufficiently charged for your trip.
- Check that the quick releases are fastened and secured each time your pedelec has been left unattended – even if it is for just a short time.

3.8 Legal Regulations



Please stay informed about the national regulations applicable in your specific country.

Before riding your Pedelec on public roads, read up on the national regulations applicable in your specific country. This section provides information on how the pedelec must be equipped to be allowed on public roads.

It includes information on:

- Which light systems have to be installed or carried with you?
- Which brakes must the Pedelec be equipped with?
- There may also be age restrictions that apply to riding in specific areas.
- For example, the issue of children riding on public roads is addressed here.
- If there is an obligation to wear a helmet, it is stated here.

4 ELECTRONIC COMPONENTS



In order to prevent a malfunction, the following instructions should be observed:

- Operating Temperature: -15 – 60 °C
- Storage Temperature: -20 – 35 °C
- Storage Humidity: 30 % – 70 %

4.1 Important Instructions



The electrical system of your Pedelec is very powerful. If you notice any damage to the electrical system, remove the battery immediately. After a fall or accident, live components may be exposed. If you have a question or problem, please contact your dealer. A lack of expertise can lead to serious accidents.



Before performing any work on your Pedelec, disconnect the electrical system and remove the battery.



Do not clean the Pedelec with a steam jet, high-pressure cleaner or water hose. Water may seep into the electrics or drive and destroy the equipment.



The operating temperature should be between -15°C and +60°C. The recommended storage temperature is between -20°C and +35°C



Only perform operations described in this manual. Do not interfere with or modify the system. No modules may be disassembled or opened. If in doubt, always contact a specialist dealer.

Replace parts that are defective or worn, such as the battery, charger, cable, with original spare parts produced by the manufacturer or parts recommended by the manufacturer. Otherwise, the warranty and/or manufacturer's warranty will

be voided. If non-original or incorrect spare parts are used, the pedelec may not function correctly. In the event of a defect, contact an authorized dealer who carries out repairs with original spare parts only.

Improper operation of the drive system and changes made to the battery, charger or drive may result in injury or costly damage. In this case, the manufacturer declines any liability for the damage incurred. Changes to the electrical system may result in criminal prosecution. This may be the case if the maximum supported speed is modified.

4.2 Batteries

i Your Pedelec can be supplied with three different types of batteries. Detailed specifications can be found in the table below.

Model numbers: BT C01.340.UART, BT C01.450.UART



4.2.1 User Instructions

! Please read the battery instructions and the battery label before use.



CAUTION

- Risk of fire or explosion if battery is used with an incompatible system.
- Do not open, disassemble or pierce battery due to risk of short circuit, fire or explosion.
- In case of drop, shock or similar event, do not continue to use battery and return immediately for examination.
- Only use the original charger as supplied with battery due to risk of fire or explosion.
- Disposal of used batteries should follow locally enforced regulations.
- Please carefully read manual before use.

Battery : 12C1 R 1865 3 7.8
 Model : HT1203AA
 Voltage : 43V
 Capacity : 7.8Ah
 Power : 340Wh
 Manufacturer : HiTech



BT C01.340.U A2Q9210272

! Risk of fire or explosion if battery is used with an incompatible system.

Do not open, disassemble or pierce battery due to risk of short circuit , fire or explosion.

In case of drop, shock or similar event, do not continue to use battery and return immediately for examination.

Only use the original charger as supplied with battery due to risk of fire or explosion.

Disposal of used batteries should follow locally enforced regulations.

Please carefully read manual before use.

- The battery is not shipped fully charged. Recharge the battery completely before the first use and before storing.
- After the first three charging cycles, fully charge the battery. This will give you the full capacity of your battery. If the battery is continuously discharged during later use, its service life will be considerably reduced.
- In normal operating conditions, partial charges will increase the battery life. Never leave your battery completely empty, and recharge it even after a short period of use.



A special charger provided by BAFANG must be used to charge these batteries.

- Do not charge the battery for longer than the charging time listed in the Specification table.
- Do not bring electrical contacts together. Do not destroy or disassemble the battery yourself. Do not store or use the battery in humid places so as to avoid any danger.
- When disposing of battery, ensure you respect regulations. Do not immerse in fire or water.
- When in use, the battery should be kept away from heat sources, high voltage power supplies and children.
- Do not drop the battery.
- When storing the battery for a long period, make sure it is charged to at least half its capacity, and charge it again three months later. Do not wrap it with conductive material, as to do so will cause damage due to direct contact between the metal and the battery. Store the battery in a dry place.
- Keep the battery out of the reach of children, and especially ensure they do not bite or swallow the battery.
- If the battery appears to be in an unusual condition, seems dirty or presents a strange odor, do not use. Faulty batteries should be returned to the vendor.

4.2.2 Notification

- The battery should not be left in direct sunlight so as to avoid over-heating, distortion, smoking or weakening its performance and product life.
- The battery should always be kept away from children. Do not allow children to remove the battery from the pedelec or the charger, or to play with it.
- Do not allow the battery to leak on skin or clothes.
- If touched, rinse off with clean water to avoid skin discomfort.
- If the battery is used in any other technical environment, please contact your manufacturer for details on how to get the best performance, as well as information on its maximum current and fast charge conditions and any special applications.
- Do not microwave or use in any other cooking appliance.
- Distance the battery from cell phones or chargers if it is hot to the touch, leaking or odorous, and dispose of it. Faulty batteries will cause over-heating, smoking or burning.
- Do not touch a leaking battery. Leaking electrolytes can cause skin discomfort. If this battery acid comes into contact with the eyes, do not rub and immediately rinse with clean water then go to hospital for treatment.
- Note: If the battery is completely discharged, charge it as soon as possible. Leaving the battery uncharged for long periods of time will damage its capacity.

4.2.3 Caution



Do not disassemble the battery.

The battery contains protective components and will internally short-circuit to avoid danger. Mishandling, such as improper disassembly, may destroy its protective functions and cause it to overheat, smoke, distort or burn.



Do not intentionally short-circuit the battery.

Do not touch or connect the plus and minus contact with metal. Do not allow the battery to come into contact with metal elements in storage or in use. If the battery is short-circuited, its current will be magnified, which will cause damage and make the battery over-heat, smoke, distort or burn.



Do not heat or burn the battery.

Heating or burning the battery will cause the isolated elements in the battery to dissolve, the protective function to stop or the electrode to burn or over-heat, which in turn may cause the battery itself to over-heat, smoke, distort or burn.



Avoid using the battery near a heat source.

Do not use the battery near a fire or stove, or at over 60°C, as over-heating will cause the battery to internally short-circuit and make it over-heat, smoke, distort or burn.



Avoid charging near exposed flames or in direct sunlight.

Doing so may cause the internal protection function to short-circuit and lead to abnormal chemical reactions or functional faults, which will lead to over-heating, smoking, distortion or burning.



Do not damage the battery.

Do not allow the battery to be gouged, forged or dropped, as this may cause it to over-heat, distort, smoke or burn, and result in danger for the user.



Do not directly weld on the battery.

Any application of heat will cause the isolated elements to dissolve within the battery which will affect its protective function and life cycle, as it will over-heat, distort, smoke or burn.



Do not charge directly off the power socket or a car cigarette lighter.

High voltage and amplified current will damage the battery and reduce its life cycle, as it will over-heat, distort, smoke or burn.

4.2.4 Specifications

Basic settings	BT C01.340.UART	BT C01.450.UART
Power	340Wh	450Wh
Charging time	4.5 h with a 2A Charger	6.5 h with a 2A Charger
Operating Temperature during Charging	0° – 45 °C	0° – 45 °C
Discharge	-20° – 60 °C	-20° – 60 °C
Storage (At 35% SOC , -10° – 35 °C)	6 Months	6 Months
Riding Distance	Min. 35km	Min. 50 km
Position	Carrier	Carrier
Dimensions (L * W * H)	408*123*70 mm	408*123*70 mm
Weight	3 KG	3.5 KG
Charger	Special 5P charger	Special 5P charger
Certification	CE/UN38.3	CE/UN38.3
Warranty	24 months *	24 months *

* from the date of sale, check your bicycle brand warranty papers for the specific details.

4.3 Charger



Please read the charger instructions and the charger label before use.





Charger

The charger is specially designed for charging lithium-ion batteries. It is equipped with an integrated fuse and protection against overcharging.



Keep the charger away from children and animals. Small children and animals may damage the cable while playing. This can lead to an electric shock, a malfunction or a fire.

- The charger must not be used by children, or by persons with limited physical, sensory or mental capabilities, unless under the supervision of a responsible adult.
- Make sure the charger is clean. There is a risk of electric shock.
- Do not use your charger in humid or dusty places.
- Avoid direct sunlight.
- Disconnect the charger from the power supply when not in use.
- Only use the charger that came with your pedelec or one from the same manufacturer.
- Don't cover the charger while it is in use. It could otherwise short circuit or cause a fire.

- When you clean the charger, unplug it from the electrical socket first.
- When charging takes longer than shown in the specifications table, stop charging.
- After charging, remove the battery from the charger and unplug the charger.

4.4 Hub motor



Your Pedelec is equipped with a 250 Watt front-wheel electric motor, which also forms the hub of the front wheel.



Motor/Product Model: FM G320.250.R



Keep in mind that the motor of your Pedelec can heat up during long uphill runs. Do not touch the motor, as you may get burnt.



The drive is activated as soon as you push down on the pedal. The degree of support depends on the settings on the control unit. As soon as you stop pedaling while driving, or when you have reached the maximum speed, the drive will be disabled. The support is automatically reactivated as soon as the speed is below the maximum support speed and you reapply pressure to the pedal.



Note that if the road surface is slippery (e.g. due to rain, snow, sand), there is a risk that the front wheel of your Pedelec may spin and slide.

5 OPERATION

5.1 Installing the battery

i For correct insertion, the battery must be inserted and locked from the rear of the casing as far as it will go. Without contact with the battery, the electric drive of your pedelec will not work.

1. If your battery has an on/off switch, always turn off the battery before inserting it into the holder.
2. For the battery to be inserted, the lock must be unlocked. You can lock and unlock the battery by turning the key provided.
3. Slide the battery along the rail track into the connector on the rail as far as it will go, then turn the key to lock the battery.
4. Remove the key to avoid losing or breaking it.

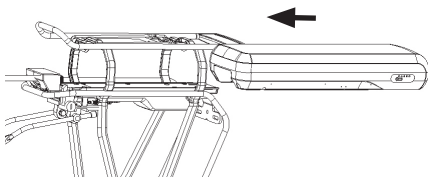

5.2 Removing the battery

When removing the battery, proceed as follows:

1. Switch off the electric drive system and, if possible, the battery.
2. Unlock the battery.

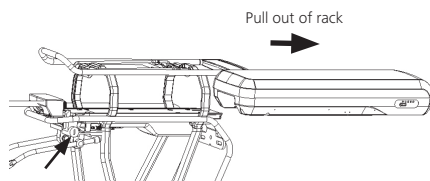



3. Remove the battery from the casing/battery holder.









Hold the battery tightly as it is heavy.



5.3 LED capacity and state of charge indication

- Press the  button to wake up from Sleep mode
- Hold down the  button for 5 seconds to wake up from Deep Sleep mode

Then check the current charge level of your battery by pressing the on/off button of the battery. The charge status is indicated by LEDs, which are illuminated for different charging states as listed in the following table.

LED	LED state	State of charge	Notes
	First LED flickers	$\leq 5\%$	When the system is triggered in operation mode: Press the  button for 1 second for the BMS to display the charge of the battery on the LEDs for 5 seconds. Hold down the button for 5 seconds for the BMS to display the capacity of the battery on the LEDs for 5 seconds. After this, the BMS will turn off the LED display to save battery power.
	One green light	$5 < C < 10\%$	
	Two green lights	$10 \leq C < 30\%$	
	Three green lights	$30 \leq C < 50\%$	
	Four green lights	$50 \leq C < 75\%$	
	Five green lights	$\geq 75\%$	

5.4 Charging the battery

-  You can charge your battery both while mounted on the Pedelec and removed.
-  Lithium-ion batteries are not subject to a memory effect. You can recharge your battery at any time, even after short trips.

Charge your battery at temperatures between 0°C and 45°C (ideally at room temperature or 20°C). Give the battery sufficient time before charging to reach this temperature.

-  Read the instructions on the charger before charging.
 1. First insert the plug of the charging cable into the charging socket on the battery, then the plug the charger into a socket.
 2. As soon as the charger is connected to the power supply, a red LED will light up.



Charger with arrow and text "red LED"

When charging is complete, the LED changes from red to green.



Charger with arrow and text "green LED"

Charging time depends on various factors. It can vary greatly according to the temperature, age, usage and capacity of the battery. You can find indications of possible charging times, if necessary, in the technical data of the battery.

When the battery is fully charged, the charging process is automatically terminated. Unplug the plug from the battery and the power outlet.

Errors – Causes and Solutions

Error description	Cause	Solution
The operating display does not light up	Mains plug not properly connected to the power supply	Check all connections and whether the charger is properly connected to the power supply
The charging indicator is not lighting up	The battery may have a malfunction	Contact the manufacturer or your specialist dealer
The charging indicator is not lighting up permanent red	The battery may have a malfunction	Contact the manufacturer or your specialist dealer



Only use the charger designed for the battery.

Make sure you use the correct mains voltage. The required mains voltage is indicated on the charger. It must comply with the voltage of the current source. Chargers marked 230V can also be operated at 220V.

- Do not touch the power plug with wet hands. There is a risk of electric shock.
- Before use, check that the charger, cable and plug are not damaged. If damage occurs, do not use the charger. There is a risk of electric shock.
- Charge the battery in well-ventilated rooms only.
- Do not cover the charger and/or battery during charging. There is a risk of over-heating, fire, or explosion.
- Only charge on a dry, non-flammable surface.



The battery has to be recharged completely at least every 3 months, in order to avoid damaging or destroying the cells.



If the charging time exceeds the usual charging times (see table), the battery may be damaged. In this case, immediately stop charging. Have a dealer check the battery and charger to avoid damage.

5.5 Switching the electrical system on and off

! Make sure that the pedals of your Pedelec are not weighed down when the system is turned on. Any load on the pedals as it is switched on may lead to power restrictions and error messages. When this happens, switch off the system and turn it on again.

Conditions

In order to activate and use your Pedelec, the following prerequisites must be fulfilled:

- A sufficiently charged battery must be used.
- The battery must be inserted correctly into the battery holder.
- The motor, control unit, control unit/battery, etc. must all be connected correctly.

You can switch the electrical system of your Pedelec on and off according to the description on the control unit, see section "Control element".

If the battery of your Pedelec is equipped with an on/off switch, you can also press the switch on the battery.



Battery switch On-Off

If you press the switch again, the system will be turned off.

6 DISPLAYS AND SETTINGS

6.1 Display C13.UART



6.2 Specifications and Parameters

- 43V Power Supply
- Maximum Operating Current: 30mA
- Power-off Leakage Current: < 1 uA
- Operating Current Supplied to the Controller: 50mA
- Operation Temperature: -20–60 °C
- Storage Temperature: -30–70 °C
- Waterproof Grade: IP65
- Storage Humidity: 30%–70%

6.3 Functional Overview

- The display adopts a two-way serial communication protocol.
- The external three-key keypad enables users to operate the display with ease.
- Intelligent battery charging level indication: thanks to an optimization algorithm, a stable display of the battery charging level is ensured, and the problem of fluctuating

battery level indications common to most displays is avoided.

- Level indication: this displays the current assistance level (level 0 to level 5).
- Fault code prompt.
- Push-assistance.
- Light control.

6.4 Items to be shown on the Display



- State of charge indication: Indicates the charging status level.
- PAS level indication: Indicates the level selected.
- Light ON/OFF indication: Indicates the status of the light.
- Power unit indication: Indicates the current power.
- Speed indication: Indicates the current speed, max. speed and average speed.
- Riding Records: Indicates trip and odometer.
- Error code indication: Indicates error code.
- Setting indication: (such as: modes, auto shut-off time, backlight grade, etc.).

- 1 Lamp status indication
- 2 State of charge indication
- 3 Riding record
- 4 Assistance level indication
- 5 Speed unit indication
- 6 Unit indication
- 7 Setting indication
- 8 Speed indication
- 9 "Down" button
- 10 Power on/off button
- 11 "Up" button

6.5 Usual operation

 There are three buttons (MODE, UP, DOWN) on the DP C13.UART display that represent the following functions respectively: MODE, UP, DOWN.

6.5.1 Power ON/OFF

- To switch ON the Pedelec system, hold the MODE button for 2 seconds.
- To switch OFF the Pedelec system, repeat the process and hold the MODE button for 2 seconds.
- When switching off the Pedelec system, the leakage current is less than 1uA.
- When the Pedelec remains parked for more than 5 minutes, the Pedelec system switches off automatically.
- After switching on the Pedelec system, the display shows Running Speed and Total Distance as well as the battery indicator and assistance level.

To change the indicated information, press the MODE button to opt for the following:

Total range"ODO"(Km) → Trip Distance (Km) → Remaining Distance (Km) → Trip Time (Min.) → Motor Power(W)→ Calory(C) → Max Speed(Km/h) → Average Speed(Km/h).

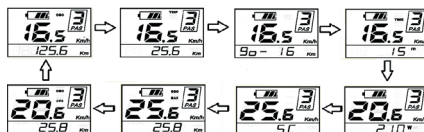

6.5.2 Push-assistance



The push-assistance function may only be used when pushing the Pedelec. There is a danger of injury when the wheels of the Pedelec are not in contact with the ground while using the push-assistance function.

- To access the push-assistance mode, hold the DOWN button; the Pedelec will travel at a uniform speed of 6 kmph.
- The screen will display "P" while the push-assistance is operational.
- The push-assistance function switches off as soon as you release the DOWN button.



Push-assistance Mode

6.5.3 Light ON/OFF button

- To switch on the display's backlight and the headlight of the Pedelec, hold the UP button for 2 seconds.
- Repeat the process of holding the UP button for 2 seconds, and the backlight and headlight will be switched off.

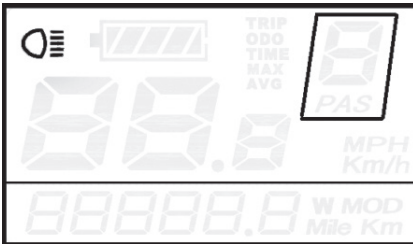

Light/backlight interface

6.5.4 PAS level selection

i The assistance level indicates the motor's output power.

- The default value is level "1".
- The default power ranges from level "0" to level "5".
- The output power is zero on level "0".
- Level "1" is the minimum power.
- Level "5" is the maximum power.
- To change the assistance level, press the UP or DOWN to increase or decrease until the desired assistance level is displayed.

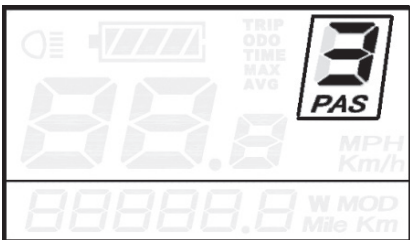

Assistance Level "3"

6.5.5 Clearing your Trip Distance

- To clear your trip distance, hold both the MODE and the DOWN button for 2 seconds: The Trip Distance will be reset.M

6.5.6 Clearing the Max speed,Average Speed and trip time

- To clear the Max speed,Average Speed and trip time,hold both the MODE and UP button for 2 seconds

6.5.7 Battery Indicator

i The 5 battery bars represent the state of charge of the battery. When the battery is low, the battery will flash to inform you that the battery needs to be recharged immediately

Bars	State of charge – Range	Example
5 bars	$\geq 75\%$	
4 bars	$50 \leq C < 75\%$	
3 bars	$30 \leq C < 50\%$	
2 bars	$10 \leq C < 30\%$	
1 bar	$5 < C < 10\%$	
Frame flickers	$\leq 5\%$	

Battery Indicator

6.6 Primary Settings

- Once the Pedelec system is switched ON, to access the Primary Settings menu, hold both the UP and DOWN buttons for 2 seconds.

- i** Never change settings while the Pedelec is in motion.

6.6.1 Unit Conversion "km/mile"

- i** U represents unit settings

- "1" is for miles, "2" is for kilometers.
- The default value is "2".
- To convert the units, press the UP or DOWN button to increase or decrease until the desired setting is displayed.
- To save a changed setting, hold the MODE button for 2 seconds and then exit settings.



Mile and Kilometer Conversion Settings Interface

6.6.2 Backlight Contrast Settings

- i** bL represents backlight contrast settings.

- These range from 1 to 8; Level.
- "1" is the lowest brightness.
- Level "8" is the highest brightness.
- The default value is "1".
- To modify the backlight brightness, press the UP or DOWN button to increase or decrease until the desired setting is displayed.
- To save a changed setting, press the MODE button and then access Wheel Diameter Settings.

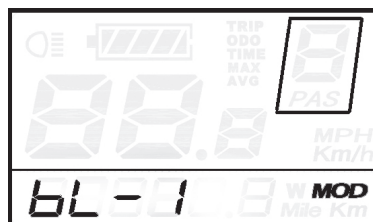

Backlight Brightness Settings Interface

6.6.3 Automatic Power-Off settings

- i** oFt represents the Automatic Power-Off Settings.

- The default value is 5 minutes or as specified by the owner.
- To change the basic settings, press the UP or DOWN button to increase or decrease until the desired value is displayed.
- These values range from 0 to 60 minutes. 0 means the display won't switch off automatically, while 60 means the display will switch off automatically after the Pedelec has been parked for more than 60 minutes.
- To save a changed setting and access the Assistance Level Selection interface, press the MODE button.



Automatic Power-Off Interface

6.6.4 Error Code Indication

- i** If there are errors pertaining to the electronic control system, the error code will appear automatically.



Error Code Indication

-  If an error code appears, take the Pedelec to a Service Center. Do not ride it until the Pedelec has been serviced.

6.6.5 Error Code Review

- The system can store a maximum of 10 error codes out of 20 available error codes
- To check the information, press the UP or DOWN button to review all the Error Codes.
- To exit the Advanced Settings, press the MODE button to return to the Unit Conversion between miles and kilometers.
- To clear the Error Code, hold the UP, DOWN and MODE buttons simultaneously for 2 seconds.



Error Code Memory Interface

6.6.6 Exit settings

- When in Settings, press the MODE button to confirm input.

- Hold the MODE button to save your settings, then exit the current settings.
- Hold the DOWN button to cancel the operation and discard your settings, then return to the previous menu.
- After 1 minute without use, the display will exit the settings automatically.

6.7 Error code definition

 This HMI DP C13.UART can indicate all errors occurring on the pedelec.

Error code	Error definition	Solution
0x07	High voltage protection	Check the battery voltage
0x08	Fault with motor hall sensor inside	Have your dealer check the motor stator
0x10	The motor temperature reaches to the max protection value	Stop riding and wait until the LED stop flickering
0x12	Fault with current sensor inside controller	Have your dealer check the controller
0x13	Fault with temperature sensor inside battery	Check the battery
0x21	Fault with wheel speed detecting sensor	Check the motor stator
0x22	BMS Communication fault	Replace the battery
0x30	Communication fault	<ol style="list-style-type: none"> 1. Check the connectors between the EB-BUS and the controller 2. Replace the controller

7 MAINTENANCE AND REPAIRS

i Keep all components of the electrical system clean. Clean gently with a damp, soft cloth. The components must not be immersed in water or cleaned with a water jet or steam jet. If the components are no longer functional, contact your dealer.

7.1 Installation and removal of the front wheel with motor

! Only have maintenance, repairs and repair work carried out by qualified personnel and only with original spare parts. In case of a flat tire or other technical problem, let your dealer carry out the repairs.

i When cabling the product or installing parts on the pedelec, be sure to disconnect the battery. Not doing so may result in electric shock.

When installing the front wheel with the front wheel hub motor, proceed as follows:

Rotation direction

Looking at the motor from the cable side, the motor rotates clockwise when the motor is turned on; when the motor is turned off, the wheel runs in a clockwise direction.

1. Insert the wheel in the center of the fork.

i Be sure to observe the direction of rotation of the front wheel hub motor. The cable must be positioned on the right side.

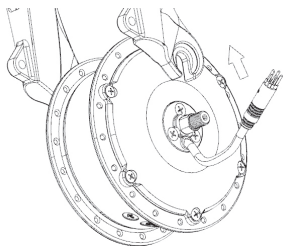

2. Please align the flat surface of the axle with the flat surface on the dropout and make sure the cable goes downwards, then put the whole motor into the dropout.

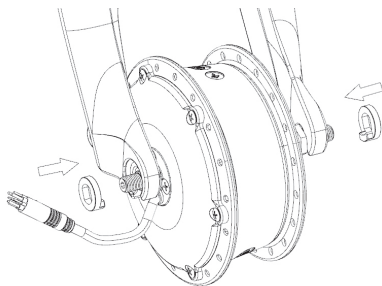

Loose axle lock washer and motor cable

3. Put the rotation stoppers on both sides of the dropout through the shaft, making sure the protrusion goes downwards into the opening of the dropout.

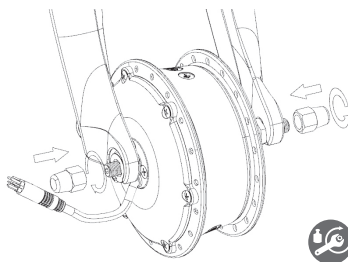

Screw the flange nuts on both out sides of the rotation stoppers on the axle. Tighten the nuts with the correct tightening torque. This is 30 Nm.

i A torque wrench must be used.

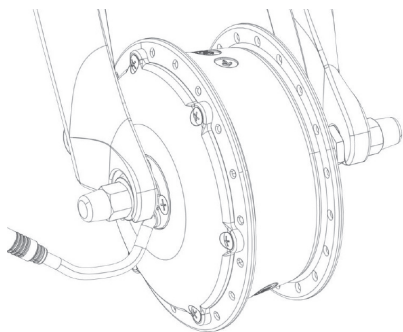

4. Hold and mount the cable along the right fork with the correct tools and parts.



5. Connect the motor cable connector to the connector of the controller cable.

i The housings of the coupling and the connector are marked with arrows. Both arrows must point towards each other when they are plugged together to ensure a correct connection.

6. Depending on the brake used: Fix the brake actuation cable correctly. Refer to the brake manual provided. Specialist knowledge is required to carry out this step correctly.

i For removal, please follow steps 1 to 6 in reverse order.

7.2 Storing the battery

i If you do not use your Pedelec for an extended period of time, remove the battery, charge it (60-80%) and store it separately in a frost-free, dry room.

- Check the charge level every 3 months and recharge if necessary.
- Store your battery at a temperature between -10°C and 35°C .
- Avoid storing in direct sunlight.
- To prevent deep discharge, the battery will go into sleep mode after a certain time.
- Do not expose the battery to temperatures below the permissible storage temperature of -10°C to 35°C . Note that temperatures of around 45°C are common near heaters, in direct sunlight or in over-heated vehicle interiors.

i If you notice the battery becoming hot during use, charging or storage, developing a strong odor, changing appearance, or any other abnormality, do not continue to use the battery. Immediately stop using the battery and have a dealer check it before you use it again.

7.3 Battery wear



The battery can run for approx. 500 charging. During that time, the battery capacity and range of your Pedelec will decrease. You should then replace the battery. If the range is still sufficient, you can continue to use it.

As the service life increases, the capacity of the battery slowly decreases. This also reduces the range of your Pedelec with regard to engine support. This does not constitute a defect.

The battery life depends on various factors:

- The number of charging operations (about 500 charging cycles).
- The age of the battery.
- The storage conditions.

Of course, your battery will deteriorate and capacity will be lost even if you do not use the battery. The lifetime of your battery can be influenced by the following measures:

- Charging your Battery after every ride, even short trips. Lithium-ion batteries are not subject to a memory effect.
- Avoiding driving in high gears with high levels of push-assistance.

8 CUSTOMER SERVICE



If you have any questions concerning the electrical system, please contact the manufacturer or your specialist dealer.

9 TRANSPORTING THE PEDELEC



Remove the battery before transportation and transport it separately. Cover the contacts with a transport cap to prevent the risk of a short circuit. In the case of a short circuit, there is a risk of injury and fire.

9.1 By car

You can transport your Pedelec by car as you would a normal pedelec. The weight of the Pedelec will call for a heavier-duty rack.

9.2 By public transport

The same regulations apply as when transporting a bicycle. For safety reasons, remove the battery before entering a train with the Pedelec, and do not put it back until you have dismounted.

9.3 By airplane

The battery must be considered as a hazardous material. It must be carried as such. Please consult your airline.

10 DISPOSAL CONSIDERATIONS

If parts of your Pedelec are replaced, please take note of the waste disposal instructions for your local waste disposal company. Used batteries and accumulators must not be disposed of with normal household waste.

Every consumer is obliged by law to dispose of used batteries at a collection point specifically for used batteries at a recycling center, battery trading company, specialist dealer or manufacturer.

Batteries containing harmful substances are marked with a symbol consisting of a crossed-out waste bin and the chemical symbol (Cd, Hg or Pb) of the heavy metal which is responsible for its classification as a pollutant.

For further information, please contact your local waste disposal service or your municipal administration.



Waste batteries, accumulators with lead, NiMH (nickel metal hydride) or lithium-ion technology are considered dangerous goods.

Lithium-ion batteries should be isolated on each pole with insulating tape to prevent short-circuiting, and potentially dangerous follow-up reactions. When transporting or transferring the batteries to a waste disposal facility, the provisions of the ADR (regulations for the transport of dangerous goods) apply.

i According to European Directive 2006/66/EC, defective or used batteries must not be used, and, in accordance with the European Directive 2002/96/EC, electrical equipment that is no longer usable must be collected separately and recycled in an environmentally sound manner.

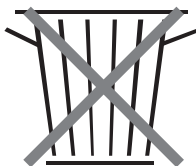

The drive unit, battery, display, control element, accessories and packaging must be recycled in an environmentally sound manner. Do not throw components of the electric drive out with household waste.

Dispose of used batteries with an authorized pedelec dealer.

11 SPECIFICATIONS

Motor

Position: Front Motor

Construction: Gear Motor

Nominal Voltage: 43 V

Rated Power: 250 W

RPM: 200 – 270

Max Torque: 30 Nm

Efficiency: 80 %

Mounting characteristics

Brake: Roller-Brake

Weight: 2.3 KG

Installation Width: 100 mm

Max. Housing Diameter: 138 mm

Cabling Shaft Side: Right

Spoke Specification: 13 G

Display

43V Power Supply

Maximum Operating Current: 30 mA

Charger

Input voltage range: 100 ACV – 240 ACV

Input power frequency: 47 Hz – 63 Hz

Efficiency: $\geq 80\%$

Rated output voltage: 49.2 V

Output current: $2 A \pm 0.2 A$

Battery

Basic settings	BT C01.340.UART	BT C01.450.UART
Nominal Voltage:	43 DCV	43 DCV
Nominal Capacity:	7.8Ah	10.4Ah
Power	340Wh	450Wh
Charge mode	CC-CV (Special 5P Charger)	CC-CV (Special 5P Charger)
Continuous Charge Current	2A – 4A	2A – 4A
Charging time	4.5 h with a 2A Charger	6.5 h with a 2A Charger

Basic settings	BT C01.340.UART	BT C01.450.UART
Operating Temperature during Charging	0° – 45°C	0° – 45°C
Discharge	-20° – 60°C	-20° – 60°C
Storage (At 35% SOC, -10 – 35°C)	6 Months	6 Months
Cycle Life	500 (60% SOC (@20 ± 5°C, Charge @ 0.2°C and discharge @ 0.5°C))	500 (60% SOC (@20 ± 5°C, Charge @ 0.2°C and discharge @ 0.5°C))
Riding Distance	Min. 35 km	Min. 50 km
Position	Carrier	Carrier
Dimension (L*W*H)	408*123*70mm	408*123*70mm
Weight	3 KG	3.5 KG

Torque table

Bolted connection	Bolt
Flange nuts/hub axle	30 Nm

12 AFTER-SALES AND WARRANTY POLICY

In all nations which apply EU law, the common conditions for warranty/liability for material defects apply. Please inform yourself about the applicable national regulations in your specific country.

Under EU law, the seller accepts liability for material defects for at least two years after the date of sale. This also covers defects which already existed at the time of sale/change of ownership. In fact, if material defects occur within the first six months, the assumption is made that these already existed at the time of sale.

One precondition for the seller assuming this liability is that the product's use and maintenance was in line with all conditions stipulated. These are outlined in the pages of this operating manual and in the supplied instructions from the component manufacturers.

In most cases, the customer can first request subsequent fulfilment. If repair fails conclusively, which is the assumption after two attempts, the customer is entitled to abatement or cancellation of the contract.

Liability for material defects does not cover normal wear occurring from the product's intended purpose. Components in the motor and deceleration system as well as tyres, light system and contact points of the rider with the pedelec are all subject to use-related wear.

Suzhou Bafang Motor Science-Technology Co., Ltd (hereinafter referred to as the "BAFANG Motor") guarantees that: During the warranty period, customers will enjoy warranty service from BAFANG for products purchased from BAFANG, as long as the products are within the warranty period and the issues are indeed quality issues concerning material and workmanship.

Warranty Period and Scope

The warranty period starts from the date of sale, and is 24 months for the motor, and 24 months for the controller, display, sensor and other components. Check your bicycle brand warranty papers for the specific details.

The BAFANG limited warranty does not cover or apply to the following situations:

1. Damage, failure and/or loss caused by refitting, neglect, improper maintenance, accident, misuse, abuse or use for competition or commercial purposes;
2. Damage, failure and/or loss due to shipping by customer;
3. Damage, failure and/or loss caused by improper installation, adjustment or repairs;
4. Damage, failure and/or loss irrelevant to material and workmanship, e.g., failure to follow instructions by users;
5. Damage, failure and/or loss caused by product's appearance or surface modifications which do not affect its function;
6. Damage, failure and/or loss due to maintenance or installation by repair stations or dealers unauthorized by BAFANG;
7. Damage, failure or loss caused by normal wear and tear.

BAFANG reserves the right to repair or replace the components, and is only responsible for repairing or replacing them.

Should pedelec manufacturers or dealers encounter quality issues when using or selling BAFANG products, they can report the purchase order number and product's serial number to BAFANG's technology service department who will check whether the products are under

Imprint

warranty or not. For products under warranty, and for minor problems, BAFANG will provide customers (dealers or pedelec manufacturers) with free spare parts so that they can correct the problem themselves. For serious issues, BAFANG will provide customers with free spare parts, show them what to do by sending them videos or documents or, in some cases, repair the products for them. For products no longer covered by warranty, BAFANG can still provide spare parts or repair the products for customers, but the incurred material cost, labor cost, freight etc. shall be undertaken by the customers.

If an end user has a pedelec equipped with BAFANG components which need repairing, they should contact the pedelec manufacturer or dealer directly.

If this warranty statement goes against a current Chinese law, the Chinese law shall prevail. BAFANG reserves the right to modify the terms without prior notice.

For the latest information, please visit the company website: www.szbaf.com.

For questions concerning your pedelec please always contact your dealer first, only then in case the manufacturer of the pedelec.

For contact details please refer to the warranty section, back cover or other included information of the brand/manufacturer.

BAFANG reserves the right of clarification with regard to the content and images:

BAFANG
Suzhou Bafang Electric Motor
Science-Technology Co., Ltd
No.9 Heshun Rd
Suzhou Industrial Park
215122, Suzhou China
bf@szbaf.com
www.szbaf.com

Legal inspection by a lawyer's office specialising in intellectual property.

In the case of delivery or use of this product outside of the scope of the aforementioned areas, the manufacturer of the pedelec is required to supply the necessary operating instructions.

© Multiplication, reprinting and translation as well as any commercial use (including extracts, in printed or digital form) is only permitted if specifically granted in writing in advance.

BF-CM-S-F02-EN-PRINT A/0 , June 2017

NOTES

NOTES

BAFANG

Suzhou Bafang Electric Motor
Science-Technology Co., Ltd
No.9 Heshun Rd
Suzhou Industrial Park
215122, Suzhou China
bf@szbaf.com
www.szbaf.com