

# HAYGAIN<sup>®</sup>

---

## hay steamers

### **HG2000 User Manual**

### **Operating & Safety Instructions**

Before using your HAYGAIN<sup>®</sup> Hay Steamer, please read this manual thoroughly and retain it for future reference.



<b>Contents</b>	<b>Page</b>
1. Unpacking your HAYGAIN	2
2. Locating your HAYGAIN	2
3. Assembling your HAYGAIN	3
4. Operating Instructions	4
4.1 Filling the Steam Generator with water	4
4.2 Loading the Hay Chest	4
4.3 Switching on	5
4.4 Steam cycle	5
4.5 Run Dry Alarm Buzzer	6
4.6 Empty Steam Generator after use	6
4.7 Safety Filler Cap	7
5. Important Electrical Considerations	7
5.1 Electrical specification	7
5.2 Plug sockets	7
5.3 Extension cables	7
5.4 Wall timers	8
6. Operating Considerations	8
7. Care and Maintenance	10
7.1 Maintaining your Steam Generator	10
7.1.1 Cleaning your Steam Generator	10
7.1.2 Descaling your Steam Generator	10
7.2 Maintaining your Hay Chest and surrounding area	11
7.3 General maintenance	12
7.4 Storing your HAYGAIN when not in use	12
8. Troubleshooting	13
8.1 HAYGAIN Troubleshooting Matrix	13
8.2 Steam is only coming from one Manifold	17
8.3 Using HAYGAIN in freezing conditions	17
8.3.1 When starting up in extreme temperatures	18
9. Guarantee	19
10. Frequently Asked Questions	22
11. Appendix	24

## HG2000 User Manual Operating & Safety Instructions

**Working safely with your HAYGAIN® Hay Steamer is only possible when these Operating and Safety Instructions are read completely and the contents contained herein are understood and followed.**

### 1. Unpacking your HAYGAIN

You will find the following:

- a) HAYGAIN Hay Chest with two fixed 5 spike Steam Manifolds.
- b) PB Steam Generator with Hose/Quick Release Fitting and 2 spare Filler Cap Seals.
- c) Plastic funnel.
- d) 1 Packet of HAYGAIN Descaler.
- e) HAYGAIN Operating and Safety Instructions.

If any of these parts are missing or damaged, notify your supplier.

### 2. Locating your HAYGAIN



**CAREFUL CONSIDERATION SHOULD BE MADE TO HEALTH AND SAFETY WHEN LOCATING YOUR HAYGAIN, RECOGNISING THAT THIS IS AN ELECTRICAL APPLIANCE THAT GENERATES HOT STEAM WHICH CAN BURN, HAS SHARP COMPONENTS AND SHOULD NOT BE ACCESSIBLE TO CHILDREN.**

**Power:** Your HAYGAIN should be located within 4 metres of a mains electrical socket. Your Steam Generator is an electrical appliance and is designed for indoor use only.

**Floor Surface:** Location must be level, well draining and easy to clean for both your Steam Generator and Hay Chest. Uneven surfaces can cause distortion to the Hay Chest and Heating Element to fail.

**Surrounding Environment:** Must be well ventilated to avoid damp conditions.

**Water Source:** Your HAYGAIN is designed to be used with clean tap water and can be easily filled with the use of a watering can and funnel.

### 3. Assembling your HAYGAIN

To attach the Steam Generator Hose to the Hay Chest: pull back the knurled brass Barrel of the Quick Release Fitting located on the end of the Hose; push firmly onto the brass Connector located at the back of the Hay Chest ensuring the Barrel slides forward into the locked position; and pull Hose to check it is secure, (see figure 1).



**ENSURE STEAM GENERATOR HOSE IS NOT KINKED OR RESTRICTED AND THE HAY CHEST IS NOT RESTING ON IT.**

**ENSURE ANY EXCESS ELECTRICAL CABLE IS HOOKED UP OFF THE FLOOR AND NOT LEFT ON THE FLOOR IN WET CONDITIONS.**

*Refer to 'Important Electrical Considerations', section 5.*

Figure 1: Quick Release Fitting

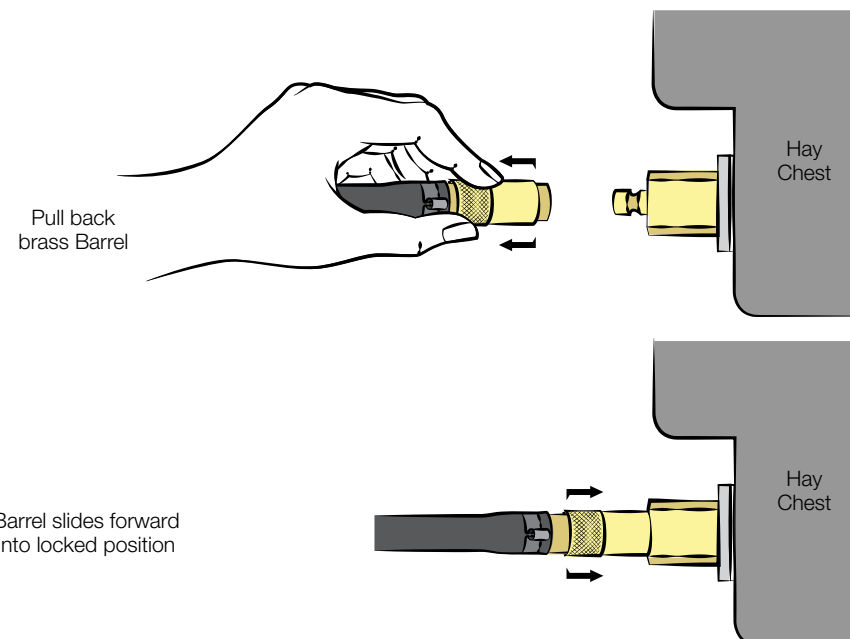

#### Note

Nutritionalists and Vets recommend introducing any dietary changes slowly. Mixing HAYGAIN steamed hay with your existing forage for a few days will allow your horse's digestive system to adapt.

## 4. Operating Instructions

### 4.1 Filling the Steam Generator with water:

Remove the Filler Cap on the Steam Generator and fill with clean tap water using the funnel provided (taking care not to spill water on the Steam Generator). The Steam Generator capacity is 8 litres and the HG2000 uses approximately 4 litres per bale. Once the Steam Generator is full, water will be visible in the Filler Spout. If water spills over from the Spout then the Steam Generator has been over filled. Excess water should be emptied until water is just visible in the Spout. If only steaming one bale, it is recommended that you fill the Steam Generator from empty with 6 litres of water using a measured watering can or container.

**Use only tap water. The use of antifreeze or other additives will seriously damage your Steam Generator, voiding the warranty and could be dangerous for you and your horse's health.**

Figure 2: Filling the Steam Generator

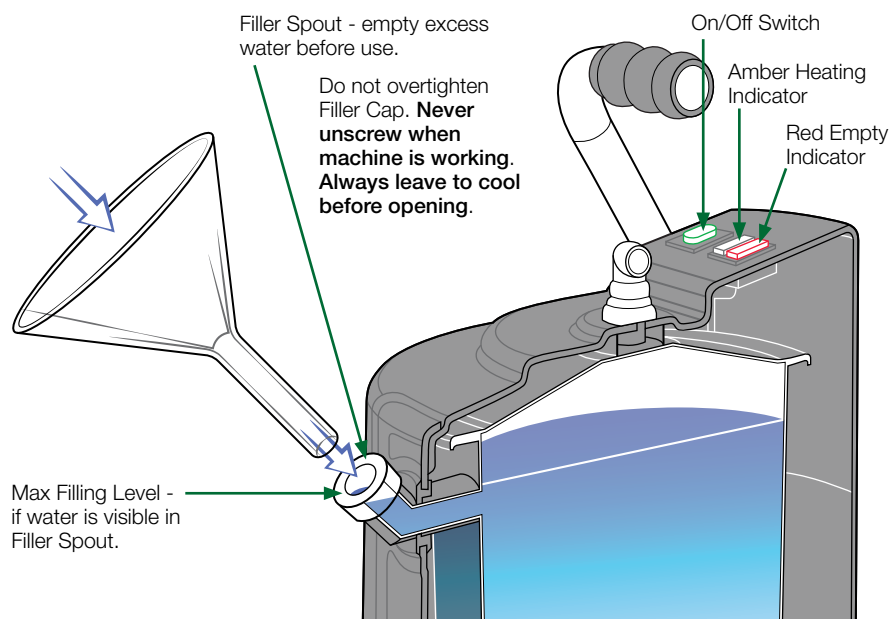

### 4.2 Loading the Hay Chest:

The HAYGAIN HG2000 will steam a fully strung bale of hay, several hay nets or loose hay from large bales. Place the hay onto the Steam Manifolds. Standard size bales should be put in the Hay Chest with the strings intact – only cut strings after the bale has been steamed and removed from the Hay Chest.

If using sections from big bales these should be placed vertically into the Hay Chest parallel to the sides. For hay nets, take two or three segments from a bale and load into a hay net. The hay nets must sit evenly and cover all the Manifold Spikes; several nets can be processed at once.

Raise lid using one of the rebated handles located at each side of the lid. Place the hay onto the Steam Manifolds and push down firmly so the Manifold Spikes pierce the hay to their full length. **Failure to do so will result in inconsistent performance.** Lower lid and fasten.

### 4.3 Switching on:

Plug the Steam Generator into a suitable power outlet and push down the **green** On/Off Switch that will illuminate to indicate the Steam Generator is 'on'. The **amber** Heating Indicator light will also illuminate to show the Steam Generator is heating up.

#### Note

The water in the Steam Generator will take 12-20 minutes to produce steam depending on the water temperature, ambient temperature and also the efficiency of your electrical supply.

### 4.4 Steam cycle:

From cold, the first bale must be steamed for at least 50 minutes and the lid Thermometer needle must have reached or be beyond the **green band** (refer to diagram (i) in Appendix) indicated around 80° Centigrade (corresponding to 100°C in the hay). **If after 50 minutes from cold the needle is not yet in the green zone, continue steaming until it is.** If you are steaming loose hay/hay nets, also steam for at least 50 minutes - even though it is not unusual for the Thermometer to read over 90 degrees, but is important you steam for the minimum of 50 minutes.

Timings are based on an average 25kg bale. Heavier bales will require a longer steaming period of up to 80 minutes. **Always ensure the Thermometer needle is in or beyond the green green band and it has had a minimum of 50 minutes from cold.**

Upon completion of the steam cycle, switch off the Steam Generator using the **green** On/Off Switch and disconnect the power supply.



**USE EXTREME CAUTION WHEN OPENING THE HAY CHEST AND REMOVING THE HAY. TEMPERATURES INSIDE IT CAN REACH IN EXCESS OF 100°C – STEAM CAN BURN.**

‘Operating Instructions’ cont’d

When opening the Hay Chest, **undo the catches and open from the side using the rebated handles located on each side of the lid - DO NOT LEAN OVER THE HAY CHEST.** Distribute the hay as required. Steamed hay will cool rapidly and should ideally be fed within 24 hours of steaming. If steaming hay nets, the hay in the centre of the net will remain hot for quite some time as the hay around it in the net insulates it. In our experience, horses are very happy to eat from the net when there is still steam coming out of it.



**METAL COMPONENTS (HOOKS, RINGS AND CLASPS) ON HAY NETS WILL BE VERY HOT IMMEDIATELY AFTER STEAM CYCLE. USE EXTREME CAUTION WHEN HANDLING.**

When steaming consecutive bales, subsequent steam cycle timings will be reduced as water is already at an elevated temperature. It is advised consecutive bales are steamed for a minimum of 40 minutes and the Thermometer Needle must be in or beyond the **green band** (refer to diagram (i) in Appendix).

For more detailed information on factors influencing steam cycle timing refer to ‘HAYGAIN Troubleshooting Matrix’, section 8.

#### 4.5 Run Dry Alarm Buzzer:

Before starting a steam cycle always ensure the Steam Generator contains enough water to complete the cycle. If this is over looked and your Steam Generator is allowed to run dry, a buzzer will sound and the **red** Empty Indicator light on top of the Steam Generator will illuminate. **TURN THE MACHINE OFF IMMEDIATELY.**

#### Note

If the Steam Generator is left switched ‘on’ without water, it will result in a heat build up and the Safety Thermofuse will activate. This will make the Steam Generator inoperable and cause the Buzzer to sound continuously. **Replacement of this component is not covered by the guarantee.**

**4.6 Empty Steam Generator after use:** (See instruction in ‘Care and Maintenance’, section 7)

Your Steam Generator should be emptied after use and regularly rinsed. Failure to do so will cause a build up of lime scale and sediment. This can cause blockages to the Manifold Spikes, Hoses, Filler Cap and Heating Element resulting in poor performance.

**Neglecting to care for your Steam Generator will invalidate your guarantee. Periodic use of a HAYGAIN descaling product is recommended.**

#### 4.7 Safety Filler Cap:

Your Steam Generator is fitted with a Safety Filler Cap. In some circumstances steam or water can be released from the Cap. In the event that this occurs turn off immediately to ensure no damage is caused to the Steam Generator or Steam Hose. **DO NOT REMOVE THE FILLER CAP – WAIT FOR MACHINE TO COOL DOWN** and refer to ‘HAYGAIN Troubleshooting Matrix’, section 8.

The potential causes of this are:

- 1) The Steam Generator has been overfilled.
- 2) The Steam Generator needs rinsing out and descaling to remove build up of sediment or scale.
- 3) The Steam Hose is blocked, kinked, restricted or frozen (see ‘Using HAYGAIN in freezing conditions’, point 8.3).

### 5. Important Electrical Considerations

#### 5.1 Electrical specification:

PB Steam Generator: 8 Litre water capacity | 2,900W | 50/60Hz~ | 230 Volt  
**THIS APPLIANCE MUST BE EARTHED**

#### 5.2 Plug sockets:

Ensure the electrical circuit is sufficiently rated to accommodate the above specification of the Steam Generator either for its sole use or use with other appliances that may draw similar wattage on the same electrical circuit.

Ensure that neither the Steam Generator nor the Hay Chest are directly located under a wall mounted socket as the steam could cause damage to it. It is recommended that all sockets are RCD protected.

#### 5.3 Extension cables:

Extension leads should only be used as a temporary measure. We do not recommend that extension leads are used as a permanent method of power supply.

Before using an extension lead check that it is correctly rated (see above ‘Electrical specification’, point 5.1) and not damaged in any way. Only use an extension lead when it is fully unwound.



**THE USE OF UNDERRATED OR WOUND UP EXTENSION LEADS IS DANGEROUS AND A FIRE HAZARD.**

If you are unsure consult a qualified Electrician.

### 5.4 Wall timers:

Wall timers should only be used if they are correctly rated and suitable for the environment in which you are using your HAYGAIN (see 'Electrical specification', point 5.1).

Wall timers should be regularly inspected to ensure they are securely fitted into the wall socket and the Steam Generator plug is firmly fitted into the wall timer. Do not use if the wall timer feels 'loose'.

If you are unsure consult a qualified Electrician.

## 6. Operating Considerations

HAYGAIN Hay Steamers are designed for steaming forage and straw bedding; ***they must not be modified in any way.***

HAYGAIN Hay Steamers are electrical steam generating appliances and therefore ***components may get very hot during operation and could cause burns.***

Your HAYGAIN should be regularly cleaned and maintained to ensure continued trouble free performance (see 'Care and Maintenance', section 7).

Persons using this equipment must be authorised to do so and must be familiar with the Operating and Safety Instructions. Relevant Health and Safety checks should be carried out.

Where necessary, protective clothing should be worn.

### ALWAYS:

- > The Steam Chest must be opened from the side using one of the rebated handles located on each side of the lid.
- > When the equipment is cold, check the Steam Hose is securely attached to the Steam Generator and the Hay Chest before operating.
- > Ensure Steam Generator and Hay Chest are on level ground before operating.
- > Raise / lower the Hay Chest lid carefully. **CAUTION STEAM CAN BURN.**
- > Use protective gloves when handling hot steamed hay.
- > Disconnect power supply and wait for the Steam Generator to cool down before re-filling with water. Mop up any water spillage before connecting to power supply.
- > Check power cable and plug before commencing use. Do not use the Steam Generator if either is damaged. Contact an approved service agent for repair.

- > Regularly check the Steam Hose for damage or distortion. Do not use the Steam Generator if the Hose is damaged. Spare hoses can be purchased directly from HAYGAIN Ltd.
- > Maintain order in the working area. Disorder increases the risk of an accident.
- > Keep children away from HAYGAIN equipment.
- > Disconnect from power supply when not in use.
- > Use only genuine HAYGAIN spare parts and approved accessories.
- > The manufacturer, an approved service agent or a competent person should only carry out servicing.

### NEVER:

- > Overfill the Steam Generator.
- > Remove or unscrew the Safety Filler Cap when steaming or when Steam Generator is hot.
- > Detach the Steam Hose when steaming or when Steam Generator is hot.
- > Over tighten the Filler Cap. Doing this can damage the rubber seal which will then require replacement.
- > Use under rated extension cables as this is dangerous.
- > Tilt or carry the Steam Generator when in use or when containing hot water.
- > Unplug the Steam Generator by pulling the electrical cord. Always switch off at the socket and pull the plug out of the socket by gripping the plug itself.
- > Allow people, children or animals to get inside the Hay Chest.

### Note

The Hay Chest is manufactured from high performance materials which are designed to flex with changing temperatures; this allows steam to emit from the Chest prior to the completion of the steam cycle.



## 7. Care and Maintenance

### 7.1 Maintaining your Steam Generator:

Flush with fresh water every few days to avoid the build up of sediment. Descale regularly to ensure no unnecessary strain is put upon the Heating Element. Hard water causes scale to form on the Heating Element and if not maintained properly this can cause the Thermofuse to activate as a safety precaution. This will cause the Steam Generator to buzz continuously rendering it inoperable until the Thermofuse is replaced.

#### 7.1.1 Cleaning your Steam Generator:

- 1) Disconnect from the power supply.
- 2) Disconnect the Steam Hose from the Hay Chest.
- 3) Half fill the Steam Generator with clean water; replace the Filler Cap and agitate vigorously - this action will suspend some sediment in the water; immediately remove the Filler Cap and empty the dirty water. Repeat this procedure until the water is completely clean.

It is recommended the Steam Generator be descaled at least every 6 weeks. Descaling frequency is dependent on usage and water hardness. Descaling frequency can be discussed with our Customer Helpline and HAYGAIN Descaler can be purchased by ringing HAYGAIN on 0333 200 5233 or visiting our website: [www.haygain.com](http://www.haygain.com).

#### 7.1.2 Descaling your Steam Generator:

- 1) Before descaling, carry out the above procedure (*'Cleaning your Steam Generator'*) to remove as much loose sediment as possible.
- 2) Leave Steam Hose disconnected from the Hay Chest.
- 3) **Always read Caution Instructions on descaling product and carefully follow directions.**
- 4) Dissolve/dilute descaler in **warm water** as directed by the manufacturer ensuring the correct water volume:descaler ratio is followed. Pour the diluted descaler solution into the Steam Generator and switch 'on'.
- 5) When the water starts to boil turn it 'off' immediately. Disconnect power and leave for a minimum of 3 hours. For best results leave to descale overnight.
- 6) **Clearly label your Steam Generator so no one attempts to use the unit whilst it contains descaling product.**
- 7) Before flushing descaler from the Steam Generator, agitate vigorously to suspend any sediment in the water, then empty.

- 8) Half fill the Steam Generator with clean water, agitate vigorously then empty water out. Repeat this process until the water drained is completely clear.



**FAILURE TO LABEL YOUR STEAM GENERATOR WHILST DESCALING OR FAILURE TO FLUSH TANK OUT AFTER DESCALING COULD BE A POTENTIAL HEALTH HAZARD TO YOUR HORSE.**

**FAILURE TO MAINTAIN YOUR STEAM GENERATOR WILL VOID ITS WARRANTY.**

#### Note

The water in the Steam Generator must be allowed to cool to a temperature which will not cause injury before emptying.

### 7.2 Maintaining your Hay Chest and surrounding area:

Clean out any loose hay in the base of the Hay Chest. Ensure the Steam Manifold Holes are clear from obstruction, and clear Drain Hole after use.

Wash out once a week ensuring the space under the Manifolds is cleaned.

When not in use disconnect the Steam Hose from the Hay Chest and tilt the Chest backwards. This allows any condensation in the Hoses to drain through the brass Connector at the side of the Chest. During freezing weather this must be done after each operation to help avoid condensation in the Hoses from freezing, (see *'Using HAYGAIN in freezing conditions'*, point 8.3).

The area surrounding the HAYGAIN should also be swept and cleaned once a week to avoid damp and mouldy conditions.

Keep the Lip Seal and the Base clean and free from loose strands of hay to ensure a good seal when in use.

When not in use, leave the Hay Chest Lid down but the Catches of the Hay Chest undone to ensure that the Lip Seal is not permanently under pressure.

After prolonged periods when the machine is not in use disinfect the interior of the Hay Chest prior to use. Further information on suitable disinfectants can be sourced from our helpline.

Make sure the Thermometer Probe on the inside of the Hay Chest Lid is not damaged.

### 7.3 General maintenance:

In addition to mandatory electrical tests, check the condition of the Steam Generator's Plug, Cable and Cable Restraint where it enters the unit's Outer Case. Ensure all warning labels are legible.

Check the general condition and fit of the Steam Generator's Safety Filler Cap and Filler Spout. Ensure there is no damage or excess corrosion and there is no hay or chaff in the Safety Filler Cap.

Ensure no Hoses or fittings are damaged and they fit correctly - (see section 3).

### 7.4 Storing your HAYGAIN when not in use:

The Hay Chest should be cleaned appropriately before storing.

The Steam Generator should be emptied and cleaned. The electrical cable should be coiled around the handle and it should be put in a dry location.

If the Steam Generator is not to be used for an extended period it is recommended the unit be descaled before it is stored away.

When recommencing use, the Steam Generator should be checked to ensure there has been no damage to the cable from rodents etc. and the plug is clean and untarnished to enable proper electrical connections. Dirty and damp plugs are a hazard and must never be used.

The Hay Chest should be sterilised before use. Further information on suitable disinfectants can be sourced from our helpline.

## 8. Troubleshooting

### 8.1 HAYGAIN Troubleshooting Matrix









**WARNING: YOUR HAYGAIN OPERATES AT HIGH TEMPERATURES AND PRODUCES STEAM WHICH CAN BURN - USE EXTREME CAUTION. TROUBLESHOOTING SHOULD ONLY BE CARRIED OUT BY A COMPETENT PERSON.**

? The steam cycle takes longer than normal.	
<i>Probable Cause</i>	<i>Solution</i>
Ambient/water and bale temperature is low, therefore starting temperature of the hay and water is lower than normal.	Steam hay for longer than normal ensuring that the Thermometer reaches at least 80°C (indicated in the green band - refer to diagram (f) in Appendix).
Bale being steamed is heavier than normal - if you change batches of hay, new bales may be heavier or denser.	The greater the weight of hay that is steamed per cycle, the longer it takes to reach temperature (like cooking meat in an oven). Increase steaming time until Thermometer reaches at least 80°C (indicated in the green band).  Dressing the top of the hay with 3 litres of water can assist with the conduction of the heat within the bale and help to reduce the steaming time.
Element is scaled up reducing its efficiency.	Flush out the Steam Generator and descale (see point 7.1.2).
Electricity voltage may be lower than normal. This can happen in the winter when demand is high and also if you are running kettles, washing machines and heaters at the same time.	Check you have sufficient power supply to run all the equipment in your yard - if in doubt consult a qualified Electrician. If the supply is sufficient but the voltage is low then you will need to steam for longer.
<b>Note - The use of hot water in your Steam Generator will help to speed the warm up time which will assist in reducing the steam cycle time.</b>	
? Hay is not steaming properly / steam is not coming from all Manifold Spikes.	
<i>Probable Cause</i>	<i>Solution</i>
Hay bales are very dense/heavy or the hay is very loosely packed.	It may be necessary to steam the hay for longer. Dressing the top of the hay with 3 litres of water can assist with the conduction of the heat within the hay and help to reduce the steaming time.
Check the HAYGAIN is on level ground.	If your Hay Chest is not on level ground steam will find the easiest exit and may favour some Manifold Spikes over others.



'Troubleshooting' cont'd

 <b>Hay is not steaming properly / steam is not coming from all Manifold Spikes (cont'd).</b>	
Probable Cause	Solution
Manifolds require re-balancing	Firstly steam up without any hay in the Hay Chest. <b>Note</b> - it is normal for water to bubble and spurt out of the Spikes as steam is generated. If steam is not coming from all Spikes, restrict the Hose that leads to each individual Manifold momentarily (one at a time) by pinching (using pliers and gloves) to create a back pressure, then release to clear any blockages ( <i>refer to point 8.2</i> ).
Hose from the Steam Generator to the Hay Chest is restricted or has deteriorated.	Hoses will deteriorate over a period of time and may need to be replaced. Failing to drain hoses of condensation on a regular basis and allowing hoses to freeze with condensation in them will shorten the life span of the hoses.  Replacement hoses can be ordered directly from your supplier.
 <b>The Steam Generator buzzes when full.</b>	
Probable Cause	Solution
Steam Generator has been left to run dry on previous cycle causing it to overheat which has activated the Thermofuse.	The Steam Generator needs servicing and the Thermofuse needs replacing.  Always descale the Steam Generator once the Thermofuse has been changed.
Heating Element is scaled up causing it to overheat activating the Thermofuse.	
Steam Generator has been run on an unlevel surface causing Heating Element to overheat which has activated the Thermofuse.	
Steam Generator has been switched 'on' with frozen water inside it causing the Heating Element to overheat and activate the Thermofuse ( <i>refer to 'Using HAYGAIN in freezing conditions', point 8.3</i> ).	
 <b>The Steam Generator cuts out and buzzes before water runs out.</b>	
Probable Cause	Solution
Build up of lime scale causing the thermal cut out to engage and the Steam Generator Buzzer to operate intermittently.	Descale your Steam Generator ( <i>see point 7.1.2</i> ). If this doesn't resolve the problem contact your supplier.

 <b>The Steam Generator does not operate and the indicator lights do not come on.</b>	
Probable Cause	Solution
No power supply.	Check that you have a power supply. Try plugging into another power outlet.
The fuse in the Steam Generator plug has blown.	
If using an extension lead the thermal trip may have activated or it may not be suitable - <b>WARNING INCORRECTLY RATED OR WOUND UP EXTENSION LEADS CAN BE A FIRE HAZARD.</b>	Replace with 13Amp fuse.
Green On/Off Switch has failed.	Check the extension lead is suitably rated and fully unwound. If the extension lead is correctly rated check the Thermal Reset button or read the manufacturer's instructions or warning labels on the extension lead for further information.
	Contact your supplier.
 <b>The Steam Generator amber Heating Indicator light comes on but the unit does not heat or only gets warm.</b>	
Probable Cause	Solution
Steam Generator has been over filled.	<b>Wait for the equipment to cool down.</b> Check that your Steam Generator has not been over filled. Over filling can result in water and steam being forced out of the Safety Filler Cap and may also result in other damage. Pour excess water out of the Steam Generator until water can just be seen in the Filler Spout ( <i>refer to point 4.1</i> ).
Heating Element has failed.	
	Contact your supplier.
 <b>The Steam Generator trips the circuit breaker or RCD.</b>	
Probable Cause	Solution
Power supply is not sufficient for total demand of appliances being used.	Switch off items such as kettles and heaters and check the supply is sufficient for the appliances that are being run from the circuit.  If in doubt consult a qualified Electrician.
Steam Generator has been allowed to get damp.	
	The Steam Generator should always be kept in a warm dry environment. Allow the Steam Generator to dry out for 24hrs and try again. ( <i>Also see 'Using HAYGAIN in freezing conditions', point 8.3</i> ).
<b>Note - If problem persists contact your supplier.</b>	

'Troubleshooting' cont'd

? <b>Steam is escaping from the Safety Filler Cap.</b>	
Probable Cause	Solution
Steam Generator has been over filled.	<b>Wait for the equipment to cool down.</b> Check that your Steam Generator has not been over filled. Over filling can result in water and steam being forced out of the Safety Filler Cap and may also result in other damage. Pour excess water out of the Steam Generator until water can just be seen in the Filler Spout (refer to point 4.1).
Sediment, limescale or hay trapped in Safety Filler Cap.	Wash the inside of the Filler Cap and remove any impurities. Ensure you locate the Filler Cap Seal correctly and that no hay or straw is to be found inside the Cap as this can obstruct the Pressure Release Valve. If the Filler Cap Seal is damaged, replace it (see Probable Cause below). If the Filler Cap has a build up of scale and sediment in it, this indicates that the Steam Generator is not being flushed or descaled regularly (refer to point 7.1).
Filler Cap Seal is damaged or missing.	Replace Filler Cap Seal with spare that was supplied with your unit. Ensure the replacement Seal is located in the base of the Filler Cap under the thread - (please note Seals are designed to be a very snug fit and will require the use of a screwdriver to slot firmly into place). Replacements can be ordered from your supplier. Use only genuine HAYGAIN replacement parts.
Blocked or restricted hoses.	Check the Steam Generator Hose for kinks and make sure the Hay Chest or Wheels are not sitting on the Steam Hose. <b>Wait for the equipment to cool down.</b> Disconnect the Steam Generator Hose at both ends and flush through with water. Re-attach to the Steam Generator but not to the Hay Chest. Turn on the Steam Generator. If steam no longer comes from the Filler Cap when steam appears through the Hose, switch 'off' and allow to cool. Then re-attach the Hose to Hay Chest and turn 'on' again. If steam still comes from Filler Cap it is likely that your Steam Generator Hose needs cutting down or replacing. Contact your supplier.
	If replacing the Filler Cap Seal and cutting down/ replacing the Steam Hose does not resolve the problem, the hoses within the Hay Chest will need to be replaced. Contact your supplier.
<b>Please note - Hoses will deteriorate over a period of time and may need to be replaced. Failing to drain hoses of condensation on a regular basis and allowing hoses to freeze with condensation in them will shorten the life span of hoses.</b>	

? <b>Steam is escaping from the Safety Filler Cap (cont'd).</b>	
Probable Cause	Solution
Hoses or Manifolds are frozen.	Sub zero temperatures can cause condensation in the hoses and Manifolds to freeze. Follow procedures in 'Using HAYGAIN in freezing conditions', point 8.3.
? <b>Steam is emitted from the side of the Hay Chest.</b>	
Probable Cause	Solution
HAYGAIN is reaching the end of its cycle.	It is normal for steam to be emitted from the sides of your Hay Chest when it is nearing the end of the steam cycle.
Ensure the Hay Chest is located on flat ground.	If your Hay Chest is located on uneven ground it can flex and twist as it warms up which will enable steam to escape between the Lid and the Base. Re-locate the Hay Chest to flat ground.
Hay is obstructing the Lip Seal.	Avoid hay sticking out of the unit and clear any debris from the Seal channel.

**8.2 Steam is only coming from one Manifold:**

Ensure HAYGAIN is on flat ground.

If only one Manifold is producing steam, wearing gloves and using a pair of pliers (as hoses will be too hot to handle) squeeze the hoses to try and get steam to come through the other Manifold.

If steam still favours one Manifold than the other, and not both, then squeeze the rubber pipe before the split to both Manifolds for a maximum of 10 seconds. Squeeze to restrict the pipe of the Manifold that the steam is coming out of; release the main pipe and the back pressure of steam should force the excess water/condensation out through the holes in the Spikes in the non operating Manifold. Once this is clear, (there will be water initially coming out of the holes) both Manifolds should be balanced and working.

**8.3 Using HAYGAIN in freezing conditions:**

When your HAYGAIN is not in use, your Steam Generator should always be empty and kept in a sheltered and warm (above freezing) environment.

If you are concerned there is frozen water in your Steam Generator you must allow it to defrost thoroughly. **Failure to do so will cause damage which will not be covered under warranty.**

'Troubleshooting' cont'd

Before use, ensure your Hay Chest, Internal Hose and Manifolds are not frozen. If you suspect any of these components are frozen, use an adequate amount of hot water to pour over the Hose and Manifolds. Squeeze the rubber Hose in the Hay Chest as this should break up any ice in the pipe work.

### 8.3.1 When starting up in extreme temperatures:

Turn on the Steam Generator without connecting it to the Hay Chest to ensure the Steam Hose is clear and ice-free. If the Hose is not clear (i.e. steam is coming from the Filler Cap), immediately turn the machine 'off'.

**DO NOT UNSCREW THE FILLER CAP** but immerse the Steam Hose in hot water and squeeze it to clear the frozen water. Try again.

Connect the Steam Hose to the Hay Chest. **DO NOT PUT HAY IN THE HAY CHEST.** Check that steam/condensation is coming through the hoses and Manifold Spikes.

If not, immediately switch 'off'. **DO NOT UNSCREW FILLER CAP** and defrost the Hay Chest using hot water.

After use, disconnect the Steam Hose from the Hay Chest and tip it backwards to drain any condensation that is in the Manifolds or pipe work.

You can use normal pipe insulation on the Steam Hoses to both protect them from freezing and make them thermally more efficient. The use of pipe insulation can be discussed with our Customer Helpline by calling HAYGAIN: 0333 200 5233.



**NEVER USE ADDITIVES, LIKE ANTI FREEZE, WITH THE WATER IN YOUR STEAM GENERATOR. IT CAN CAUSE SERIOUS PROBLEMS AND WILL VOID YOUR WARRANTY.**

***If there is still a problem, please contact your dealer.***

## 9. Guarantee

The guarantee covers the repair or replacement (at the discretion of HAYGAIN Ltd) of your machine or part of your machine if it is found to be defective due to faulty materials or workmanship within the guarantee period. This includes all parts and labour required to get the machine working properly again without charge.

Guarantee work is normally carried out at a HAYGAIN authorised service centre, but at the company's discretion work can sometimes be carried out on site.

Where possible we will offer a loan machine whilst repairs are being carried out. However relevant charges will be applied to cover transportation costs.

If you require a loan machine you may be offered an exchange machine and the faulty machine will be collected from you. If this is the case, no charge will be made and the exchange machine will become your replacement machine.

If any part is no longer available, we will replace it with a functional replacement part.

HAYGAIN machines are engineered and constructed for continual high performance in normal use. If a machine is used in the way indicated by these instructions and it breaks down within the guarantee period, it is our responsibility to repair, replace or exchange it.

### **Your Steam Generator is covered by a 12 month HAYGAIN Guarantee if you maintain the unit as follows:**

- Do not allow your Steam Generator to boil dry.
- Descale your Steam Generator at least every 6 weeks with HAYGAIN Descaler.
- Flush your Steam Generator out with clean water at least once every 2 weeks.
- Use clean fresh **tap/distilled water**.
- Empty the machine of water when it is not in use.
- Ensure the Steam Generator and Hay Chest are on a hard level surface.
- The machine is only to be used for steaming hay, haylage and straw.
- Regularly check the hoses for blockages.
- The warranty does not cover misuse or preventable damage.

'Guarantee' cont'd

**There are some circumstances in which a HAYGAIN Guarantee will NOT cover the repair, exchange or replacement of a machine. These are detailed below:**

- Normal wear and tear, including parts that might wear out over time (e.g. fuse, hose, seals, etc.).
- Accidental damage.
- Removal of blockages. If your machine becomes blocked, *please refer to 'Care and Maintenance', section 7*, for details of how to unblock it. If you are unsure, please call our Customer Helpline and a member of our team can help you.
- Faults caused as a result of scale or sediment build up within the Steam Generator, (*refer to point 7.1*). If you are unsure, please call our Customer Helpline and a member of our team can help you.
- **Faults caused by negligent use, misuse, neglect or careless operation of the machine, this includes:**
  - > Use of dirty water. Only **tap/distilled water** is approved.
  - > Foreign objects, such as hay and straw, found in the Steam Generator Tank or pipe work.
  - > Corrosion of the unit due to storage or outdoor use.
  - > Steam Generator not emptied of water after use.
  - > Damage to the Heating Element or Thermofuse due to lack of water in the Tank or Tank being allowed to run dry.
  - > Not ensuring the Steam Generator Tank is filled sufficiently before use if used on a timer.
  - > Damage to the Heating Element due to use on uneven surfaces.
  - > Use of the machine that is not in accordance with the Operating and Safety Manual.
  - > Use of the machine for anything other than its specific designed purpose as described in the brochure and Operating and Safety Manual.
  - > Use of parts not assembled or installed in accordance with the Operating and Safety Manual.
  - > Use of parts and accessories which are not HAYGAIN Ltd genuine components. Faulty assembly or installation of parts or accessories.
  - > Repairs or alterations carried out by parties other than HAYGAIN Ltd or its authorised agents.

**Note**

An inspection charge and carriage charge will be made if a fault is deemed to be caused by misuse.

If you have any questions about what is not covered please call our Customer Helpline: 0333 200 5233.

**The Terms and Conditions of a HAYGAIN Guarantee are as follows:**

- The guarantee becomes effective at the date of purchase or the date of delivery if this is later.
- You must provide proof of delivery/purchase before any work can be carried out on your machine under the guarantee. Please note that without this proof any work carried out will be chargeable. Please keep your purchase receipt as proof of purchase date; for reference enter these details into the back of this manual.
- HAYGAIN or its authorised agents will carry out all work.
- Any parts that are replaced will become the property of HAYGAIN.
- The repair, replacement or exchange of your machine under guarantee will not extend the period of the guarantee.

Any faults with your Steam Generator or Hay Chest should be reported immediately on receipt of the unit to the dealer you purchased it from.

## 10. Frequently Asked Questions:

### How much does HAYGAIN cost to run?

The running costs are minimal and you will use considerably less water compared to soaking. The Steam Generator uses just 2.9kW of electricity per hour.

Electricity costs vary between utility companies but typically are between 7-18p per kW/hour. In order to work out exactly how much it costs you, check your electricity bill to see how many pence per kW/hour your rate is and then multiply that number by 2.9(kW) to give you the electricity cost per hour.

*For example: if you are paying 10 pence per kW/hour, it will cost 29p per hour (the average cycle time is 50 minutes).*

### How long does it take to process the hay?

This can vary according to how densely packed the hay is, the weight of hay being processed, the ambient and water temperature and the voltage supply. The Thermometer on the Lid is there to act as a guide. When you first set up your HAYGAIN you will need to time how long it takes to reach the green band (required temperature) within the Thermometer. From then on you can use a timer set for the appropriate time.

The minimum cycle time is 50 minutes. This is based on a standard 25kg bale in mild weather conditions with a good power supply.

### Does the outside of the Hay Chest get hot?

No. All of the HAYGAIN range is made from composite materials with highly efficient thermal properties so although the inside of the Hay Chest can reach over 100°C, the outside is only warm to touch. Therefore HAYGAIN Hay Steamers are environmentally friendly and energy saving.

### Once steamed, how long before I can feed the hay and how long does it last?

The hay is very hot when you first take it out and it should be handled with care. However it cools very quickly once it is in the air and the steamed hay can be fed immediately. It is best fed while it is warm and steamy and most horses prefer it like this. Otherwise it should be used within 24 hours. If steaming hay nets, the hay in the centre of the net will remain hot for quite some time. This is because the central hay in the net is insulated by the hay surrounding it. In our experience horses are very happy to eat from the net when there is still steam coming out of it.

### What is the difference between soaking, and steaming in a HAYGAIN?

Soaking hay will dampen the spores down so they are less likely to be inhaled. Soaking, however, has also been shown to increase the bacterial content in hay. With HAYGAIN steaming, the combination of the heat and the moisture actually kills the mould spores and bacteria so the risk is completely eliminated.

### Will my horse like it?

The hay comes out of the HAYGAIN looking and feeling like life has been breathed back into it! It is warm and sweet smelling. Most horses LOVE it and find it more palatable than dry or soaked hay. Palatability trials at the Royal Agricultural College and Writtle College both concluded that steamed hay, once tasted, was the preferred choice. It is often used as an effective way to encourage fussy eaters and recovering post-op horses in Veterinary Hospitals. However, horses are individuals and we have come across the odd one that is initially skeptical about the steamed hay and appears not to like it simply because it is different. If this is the case you can try the following to encourage them to taste it:

- Mix it with their normal forage for a few days. This should be done anyway to allow the horse's digestive system to adapt to the new forage particularly if changing from haylage to hay.
- Feed the steamed hay cold.
- Sprinkle water on top of the hay prior to steaming. This will give a "wetter" steam and often works well for horses that are used to soaked hay.

### How much water will be used?

The hay will absorb the steam/water and therefore hydrate it. This brings the hay back towards its original moisture content that is approximately 15+% of its original weight. However the hay is neither soggy nor heavy. About 4L of water is processed per bale and a residue of, on average, a teacup of water (condensed steam) remains from each steam cycle. If steaming hay nets or very light/ loose bales you may get slightly more water residue at the end of the cycle.

### What is the company background?

The Propress Group has been in business for 30 years and is a worldwide leader in high quality, professional steam appliances. We have supplied International and High Street names for years from large department stores to charity shops and hotels, as well as hundreds of thousands of independent customers. Our back up and after sales service is unparalleled.

11. Appendix

Diagram (i): Thermometer

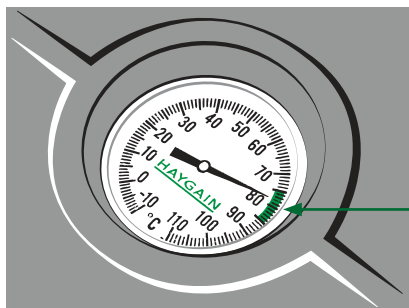

**Green band** (required temperature) on Thermometer, located on Hay Chest Lid.

Diagram (ii): HG2000 Hay Chest

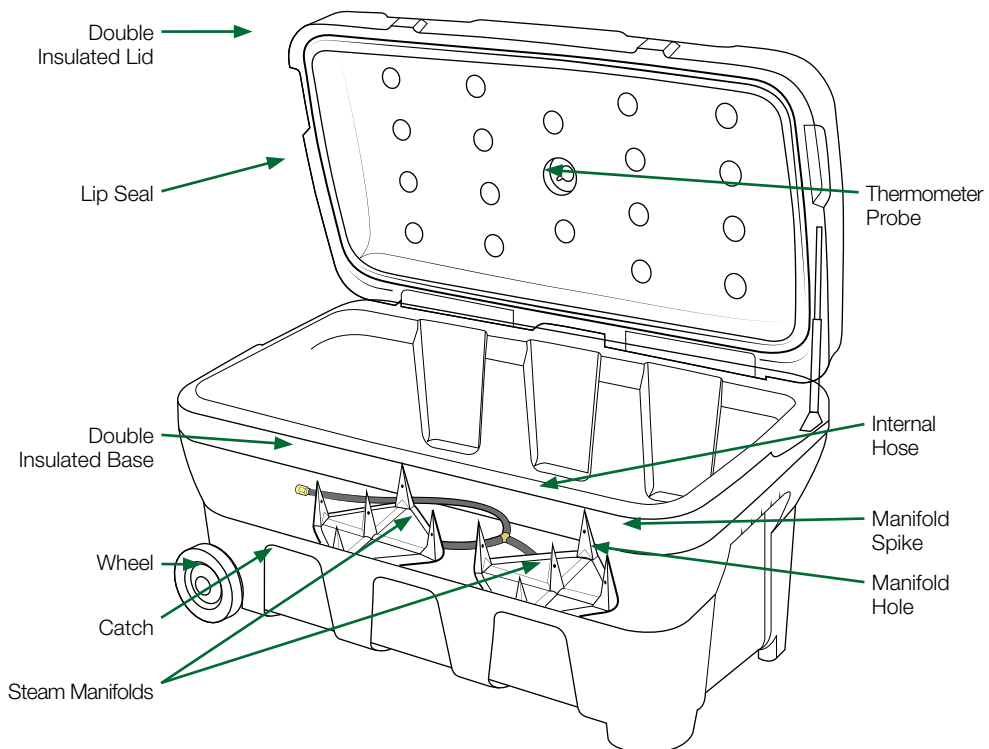
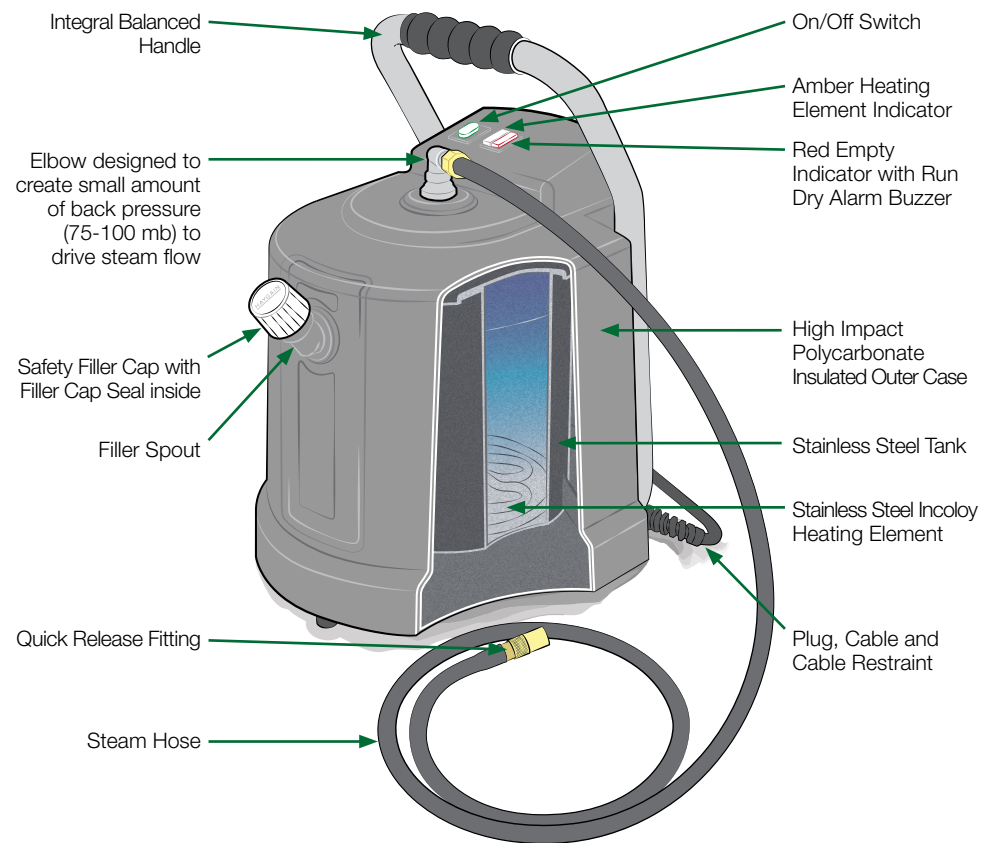

Diagram (iii): Steam Generator





### For Your Record

Area Consultant (name & contact details):

.....  
.....  
.....  
.....  
.....  
.....

I steam: Bales [ ] Loose hay [ ] Hay nets [ ]

Average weight of my bales: .....

Time to steam ~ Summer: .....

Time to steam ~ Winter: .....

### Hay Chest

Cleaned by:	Date:	Cleaned by:	Date:

### For Your Record

#### Steam Generator

Cleaned by:	Date:	Descaled by:	Date:

**Memo**

If you have any questions or comments relating to your HAYGAIN®, please contact the HAYGAIN Customer Care Team.

Tel: +44 (0)333 200 5233

Fax: +44 (0)333 200 5244

Email: [info@haygain.com](mailto:info@haygain.com)

[www.haygain.com](http://www.haygain.com)

Head Office: HAYGAIN Ltd., The Stables, Bockhampton Manor Farm,  
Lambourn, Berkshire, RG17 7LX

# HAYGAIN<sup>®</sup>

---

## hay steamers

Record your HAYGAIN<sup>®</sup> Hay Steamer serial number and purchase date here for future reference.

Serial Number: .....

Date of Purchase: .....

Date of Delivery: .....

Your HAYGAIN<sup>®</sup> Steam Generator and Hay Chest are covered by a 12 month HAYGAIN Guarantee.

Customer Helpline: **+44 (0)333 200 5233** | [www.haygain.com](http://www.haygain.com)