

UniInsulate

High quality - High performance insulation for heat exchangers

UNEX

HEAT EXCHANGERS



UNEX offers a comprehensive range of insulation suitable for use with their heat exchangers. High quality insulation is not only important to ensure that the energy being transferred inside the heat exchanger remains inside the heat exchanger - but also to protect equipment, objects and people from coming into contact with the heat exchanger that can regularly be operating at over 100°C.

SUMMARY:

- Helps maximise the efficiency of your heat exchanger
- Standard range covers -50°C to +150°C
- Simple and easy to fit
- Comply with the latest EU fire regulations
- Also available for exchanger from other manufactures
- Helps protect from burn / freeze injuries
- Customisation for specific requirements possible

PROTEX

UNEX pre-insulated UniBraz plate heat exchangers provide a single unit capable of being used for both low and high temperature applications. The clean and simple PU foam is moulded directly onto the heat exchanger, producing a vapour-tight seal. This professional solution not only looks nice but also saves on transport and storage of the exchanger and insulation as separate items.

TECHNICAL DATA	
MATERIAL	PUR rigid foam
OPERATING TEMPERATURE (°C)	-50°C to +150°C (peak / +135°C continuous)
THERMAL CONDUCTIVITY (W/MK)	0.029 W/mK
VAPOUR TRANSMISSION (μ)	> 10,000
FIRE CLASS (BASED ON EN 13501)	EN 13501 E (DIN 4102-1 B2)



RUBBERISED BARRIER

This industry standard material can be found in use throughout plant construction. As one of the most effective and cost efficient methods of insulating equipment that is used in temperatures where condensation can build on external surfaces during operation, this material seals, insulates and prevents this problem. UNEX rubberised barrier kits are pre-cut, self-adhesive and should be fitted prior to mounting the exchanger.

TECHNICAL DATA	
MATERIAL	10 or 19mm self-adhesive synthetic foam rubber (Elastomer)
OPERATING TEMPERATURE (°C)	-50°C to +105°C
THERMAL CONDUCTIVITY (W/MK)	0.033 W/mK
VAPOUR TRANSMISSION (μ)	> 10,000
FIRE CLASS (BASED ON EN 13501)	EN 13501 B (DIN 4102-1 B1)



ALUMINIUM COATED

This timeless classic remains in high demand, despite the other available options. UNEX produces this insulation in a 3 part kit, enabling retrospective fitting - even when the exchanger has already been installed. Customisation and modification of this insulation is possible for UniBraz heat exchangers (eg. special feet or mounting bolts). Insulation for the front plate is also available for this insulation.

TECHNICAL DATA	21mm
MATERIAL	21mm PUR rigid foam core (CFC, HCFC & HFC-free) sandwiched in aluminium
OPERATING TEMPERATURE (°C)	-35°C to +150°C (peak / +135°C continuous)
THERMAL CONDUCTIVITY (W/MK)	0.0206 W/mK
FIRE CLASS (BASED ON EN 13501)	EN 13501 B (DIN 4102-1 B1)
TECHNICAL DATA	50mm
MATERIAL	50mm PUR rigid foam core (CFC, HCFC & HFC-free) sandwiched in aluminium
OPERATING TEMPERATURE (°C)	-35°C to +150°C (peak / +135°C continuous)
THERMAL CONDUCTIVITY (W/MK)	0.025 W/mK
FIRE CLASS (BASED ON EN 13501)	EN 13501 B (DIN 4102-1 B2)



HARD SHELL

UNEX hard shell insulation is an easy to use 2 part insulation, held together by stainless steel spring clips at either end. This insulation is robust, good looking and easily mounted and removed - even with the heat exchanger in place. This insulation is available for many standard UniBraz heat exchangers.

TECHNICAL DATA	
MATERIAL	30mm Coated steel sheet and polyester insulation
OPERATING TEMPERATURE (°C)	-35°C to +150°C (peak / +135°C continuous)
THERMAL CONDUCTIVITY (W/MK)	0.042 W/mK
FIRE CLASS (BASED ON EN 13501)	EN 13501 E (DIN 4102-1 B2)



HARD PANEL

Specially developed for the UniBraz PB97, hard panel insulation is designed specifically for the demands of larger exchangers. The modular construction form provides not only a smart protecting cover for the exchanger but is also easy to pre-install or install on existing exchangers – even in confined spaces.

TECHNICAL DATA	
MATERIAL	30mm Coated steel sheet and polyester insulation
OPERATING TEMPERATURE (°C)	-35°C to +150°C (peak / +135°C continuous)
THERMAL CONDUCTIVITY (W/MK)	0.042 W/mK
FIRE CLASS (BASED ON EN 13501)	EN 13501 E (DIN 4102-1 B2)

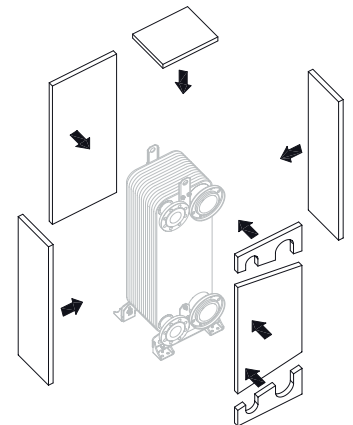

APPLICATIONS FOR PARACONNECT INCLUDE:

- Domestic and commercial heating and cooling systems
- Plant construction
- OEM Manufacturers
- Heat recovery
- Protection of equipment and people from heat / cold



Sales Network:

To find out about other uses please contact your UNEX partner.
Your nearest partner can be found on the UNEX website www.unex-eu.com