

KR 1100

230V/50Hz - 115V/60Hz

Compressivo Macchina

Frame and Chassy (Assembly)

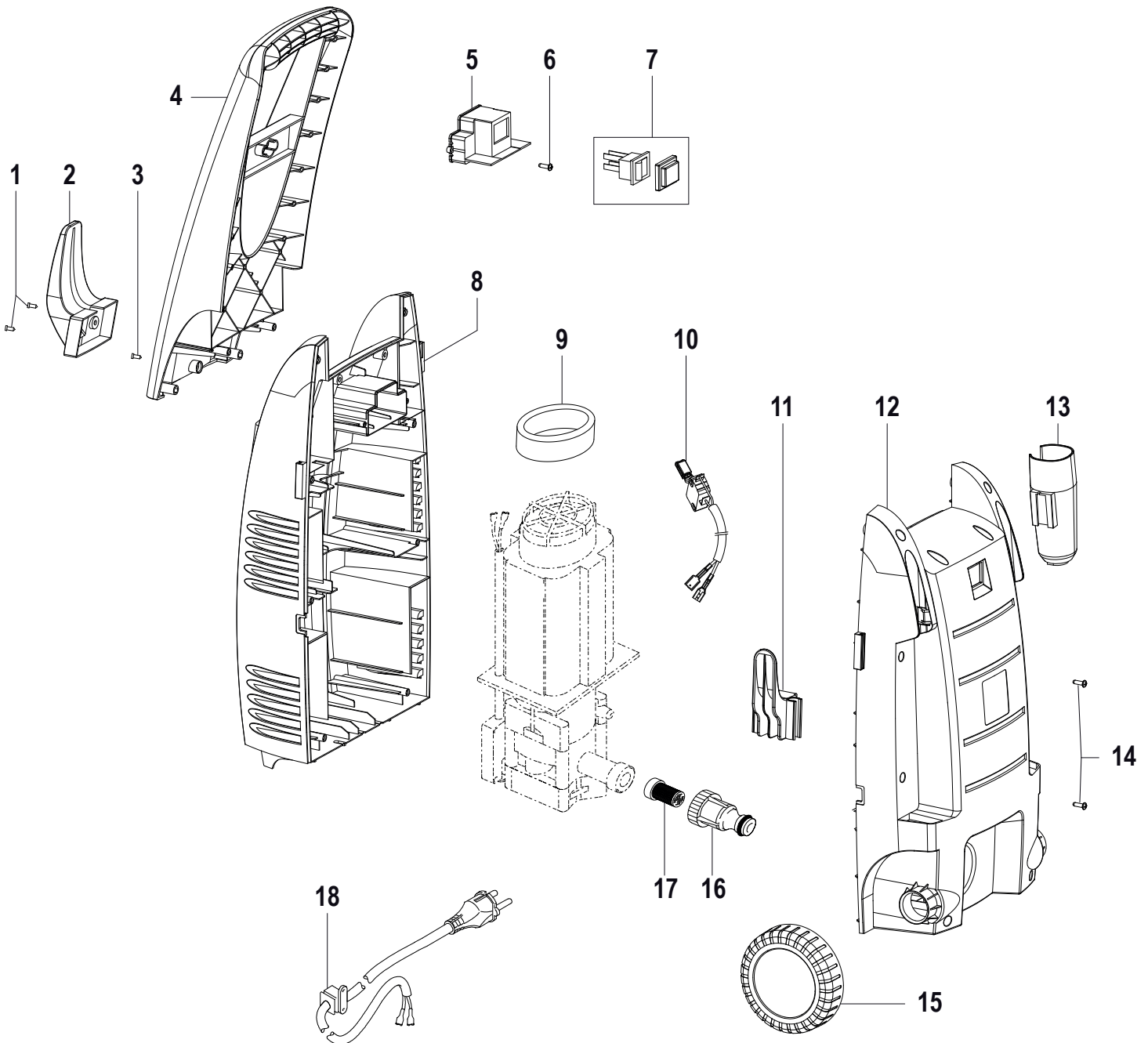

N°	Cod.	Descrizione	Description	Note	Q.ty	Model
1	3605 0148	Vite	Screw	5x16	2	
2	3002 0744	Supporto Tubo A.P.	Support H.P. Hose		1	
3	3605 0148	Vite	Screw	5x16	1	
4	1411 0053	Manico	Handle		1	
5	3001 0549	Scatola Elettrica	Electrical Box		1	
6	3605 0149	Vite	Screw	3x14	2	
7	1410 0131	Interruttore	Switch		1	
8	0477 0309	Carenatura Frontale	Front Cover	Grigio / Grey	1	
8	0477 0310	Carenatura Frontale	Front Cover	Azzurro / Cyan	1	
9	1002 0229	Filtro Fonoassorbente	Soudproof Filter		1	

N°	Cod.	Descrizione	Description	Note	Q.ty	Model
10	1002 0228	Filtro Antidisturbi	Interference Suppressor		1	
11	3002 0742	Supporto Cavo Elettrico	Support Electrical Cable		1	
12	0477 0311	Telaio Inferiore	Lower Frame		1	
13	3002 0743	Supporto Accessori	Accessories Support		1	
14	3605 0148	Vite	Screw	5x16	10	
15	2810 0104	Ruota e Copriruota	Wheel and Cover		2	
16	2803 0617	Kit Raccordo Aspirazione	Suction Coupling Kit		1	
17	1002 0227	Filtro Aspirazione	Scuction Filter		1	
18	2434 0073	Pressacavo	Cable Holder		1	

KR 1100

230V/50Hz - 115V/60Hz

Kit Ricambi

Spare part Kit

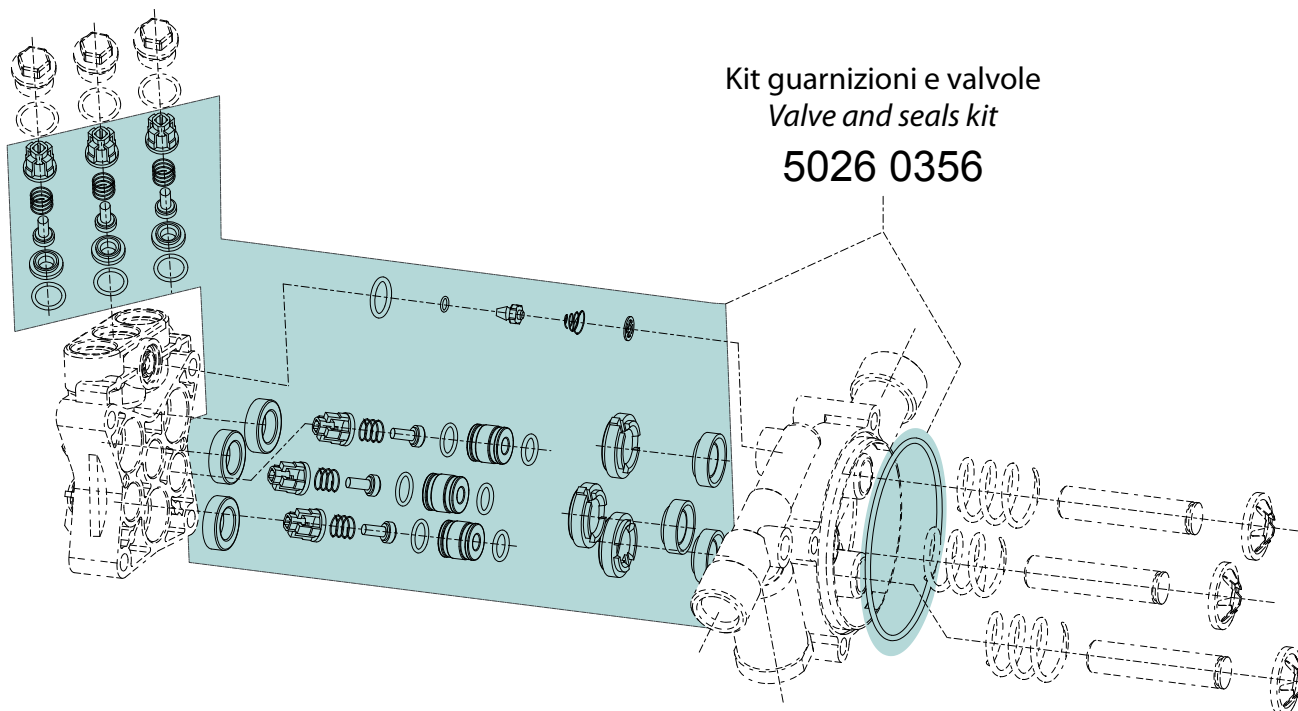

Kit guarnizioni e valvole
Valve and seals kit
5026 0356

KR 1100

230V/50Hz - 115V/60Hz

Motopompa

Motorpump

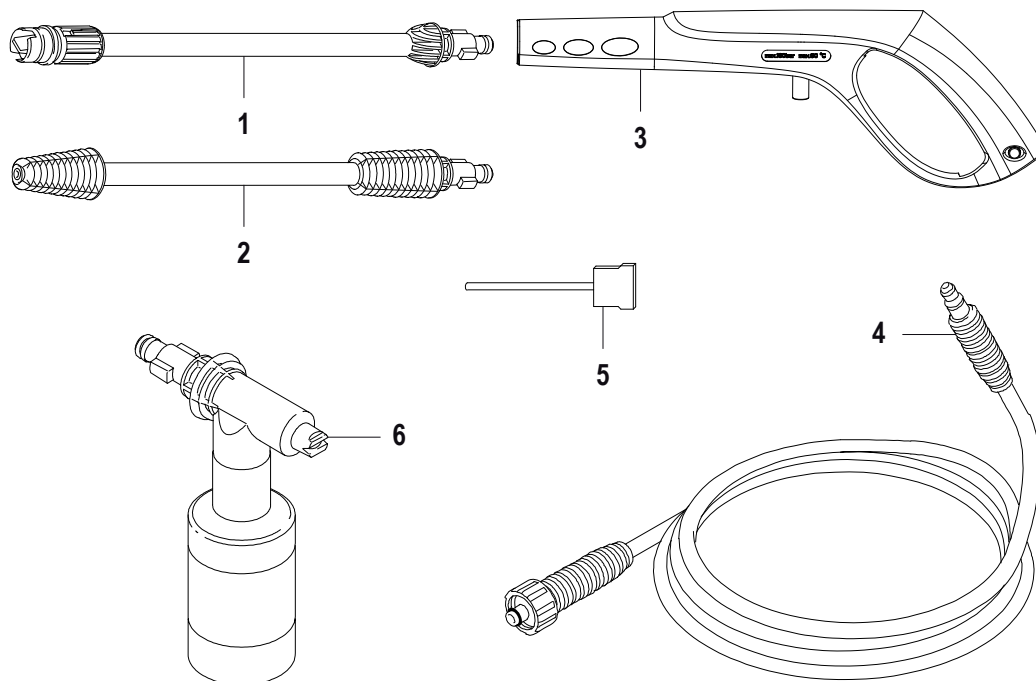

N°	Cod.	Descrizione	Description	Note	Q.ty	Model
1	3301 1209	Testina Getto Regolabile	Adjustable Lance (Blister COMET)		1	
2	3301 1211	Testina Ugello Rotante	Rotojet Lance (Blister COMET)		1	
3	2410 0170	Pistola	Spray Gun (Blister COMET)		1	
4	3301 1207	Tubo A.P.	H.P. Hose (Blister COMET)	1/4" - 5mt	1	

N°	Cod.	Descrizione	Description	Note	Q.ty	Model
5	0455 0019	Spillo Pulizia Ugello	Nozzle Cleaning Pin		1	
6	3301 1213	Lancia Schiumogena	Foam Lance Kit (Blister COMET)		1	