

## Features

- **Frequency Range**  
9 kHz to 30 MHz
- **Built-in, Battery Operated Preamplifier**
- **Electric or Magnetic Field Measurements**
- **Individual Calibration per IEEE 291 Included**
- **Three-year Standard Warranty**

## Description

The AL-130 is an Active Loop Antenna (loop size: 19" x 19" [0.5 m x 0.5 m] with electrostatic shield), operating over the frequency range of 9 kHz to 30 MHz, with built-in preamplifier. It is an active antenna, in that it has a built-in, low-noise preamplifier, which increases overall measurement sensitivity as well as the overall signal to noise ratio.

The preamplifier is battery powered (rechargeable 6V NimH battery pack). The AL-130 can also be powered by the supplied charger/power adapter. The front panel has indicators for power, battery low, amplifier saturation, as well as charging status.

## Construction

The AL-130 is designed for durability, making it the ideal choice for daily use in most environments. It is constructed using high grade aluminum, which is also powder coated for additional durability.

The output port connector is a female BNC-type connector.

## Mounting

The AL-130 has a 1/4 inch x 20 threaded hole on the under side of the preamplifier enclosure, which is used to secure the antenna to any tripod or antenna mast with a compatible mounting arrangement.

Com-Power's **AT-220 Tripod** is the recommended support for this antenna. Using this tripod, the center-point of the loop can be adjusted from 0.95 meter to 1.35 meters (37" to 53"). Com-Power's **AT-812 Tripod** can also be used, which allows height adjustment from 1.08 meters to 1.575 meters (42.5" to 62").



## Application

The AL-130 Active Loop Antenna is intended for use as an EMI test antenna for qualification-level regulatory compliance measurements per most commercial product test procedures including, but not limited to, ANSI C63.4, along with most CISPR, EN, ETSI standards.

Typically, the antenna is positioned vertically with the center-point of the loop elevated one meter above the ground. The loop is then rotated about its horizontal and vertical axis to achieve the maximum reading at each frequency.

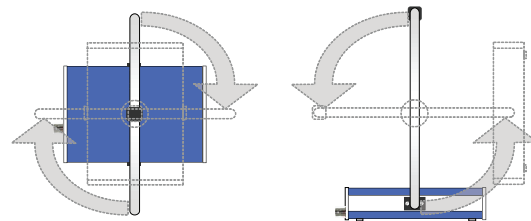

The AL-130 can be used for Electric field (E-Field) or magnetic field (H-Field) measurements. Factors are provided for both types of measurements. The relationship between E-Field and H-Field is given below:

$$H\text{-Field (dBuA/m)} = E\text{-field (dBuV/m)} - 51.5 \text{ dB}[\Omega]$$

or, in linear terms:

$$H\text{-Field (uA/m)} = E\text{-field (uV/m)} / 377 \Omega$$

where:  $377\Omega = 51.5 \text{ dB}[\Omega] = 120 \pi$  (intrinsic impedance of free space)

## Calibration

The antenna is individually calibrated at a 1 meter distance per IEEE 291; using NIST traceable equipment. The calibration data, along with certificate, are provided. Recognized ISO 17025 accredited calibration is available upon request.

### Specifications

Product Name	Active Loop Antenna
Frequency Range	9 kHz to 30 MHz
Loop Size	19" x 19" (0.5 m x 0.5 m)
Nominal Impedance	50Ω (output port)
Battery Type	6 VDC NimH (rechargeable)
Average Battery Life	10-12 hours
E-Field Antenna Factors	13.4 to 16.4 (average: 14.9) [dB(m <sup>-1</sup> )]
Saturation Level	>1 V/m / >120 dBμV/m (>2.65 mA/m) / 68.5 dBμA/m
Antenna Factor Variation	±1.5 dB
RF Connector	BNC-type (female)
Specifications	ANSI C63.4, CISPR, EN, ETSI, etc.
Dimensions (H x W x D)	20.1" x 19.7" x 10.6" [51 x 50 x 27 cm]
Weight	5.5 lbs. [2.5 kg]

Accessories available from Com-Power:



PAM-103 Preamplifier



AT-220 Antenna Tripod



SPA-800 Spectrum Analyzer

Also Available:

- AB-900A Biconical Antenna
- AM-741 Active Monopole Antenna
- AL-100, ALP-100, ALC-100 Log Periodic Antennas

$$\frac{H}{[H\text{-Field}] \text{ (magnetic field)}} = \frac{E}{[E\text{-Field}] \text{ (electric field)}} - \text{Log}^1 \left[ \frac{51.5 \text{ dB}}{377\Omega} \right] \text{ (impedance of air)}$$

All specifications are subject to change without notice. All values are typical, unless specified.

**MAGNETIC FIELD EQUATIONS**  
(AMPS per meter)

A/m = [E-Field] Strength (V/m) / 377Ω  
 dBA/m = [E-Field] Strength (dBV/m) - 51.5  
 dBA/m = Voltage (dBV) + [E-Field] Factor - 51.5  
 dBA/m = Voltage (dBV) + [H-Field] Factor

**ELECTRIC FIELD EQUATIONS**  
(VOLTS per meter)

V/m = [H-Field] Strength (A/m) x 377Ω  
 dBV/m = [H-Field] Strength (dBA/m) + 51.5  
 dBV/m = Current (dBA) - [E-Field] Factor + 51.5 dB  
 dBV/m = Current (dBA) - [H-Field] Factor  
 dBV/m = Voltage (dBV) + [E-Field] Factor

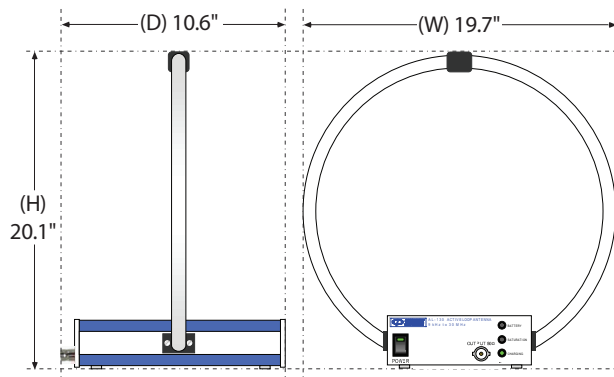

### Active Antenna Factors (E-Field & H-Field)

