



RANGE OF PERFORMANCE

Flow rate up to 160 l/min (9.6 m³/h)
Head up to 58 m

LIMITS OF USE

Manometric suction lift up to 7 m
Liquid temperature up to + 90°C
Liquid temperature up to + 40°C in the CPX version
(with technopolymer impeller)
Environment temperature up to + 40°C

CONSTRUCTION AND SAFETY STANDARDS

EN 60034-1
IEC 34-1
CEI 2-3



INSTALLATION AND USE

They are recommended for pumping clean water and liquids that are chemically non aggressive to the materials from which the pump is made. **RELIABLE AND MAINTENANCE FREE THEY ARE WIDELY USED IN THE DOMESTIC AND CIVIL SECTOR, IN PARTICULAR FOR WATER DISTRIBUTION IN COMBINATION WITH SMALL OR MEDIUM PRESSURE SETS, FOR TRANSFER IN GENERAL, FOR IRRIGATING GARDENS.**

The pumps must be installed in enclosed places, or at least protected against inclement weather.

GUARANTEE 2 YEARS subject to our general terms of sale.

CONSTRUCTION CHARACTERISTICS

- **PUMP BODY:** cast iron, with threaded ports ISO 228/1.
- **BODY BACK-PLATE:** stainless steel AISI 304 or cast iron on higher powered models.
- **BRASS IMPELLER:**
CP 100-CP 132-CP 152-CP 150-CP 170-CP 190-CP 200
- **STAINLESS STEEL IMPELLER:**
CP 130-CP 158
- **MOTOR SHAFT:** stainless steel EN 10088-3 - 1.4104.
- **MECHANICAL SEAL:** ceramic - graphite - NBR.
- **ELECTRIC MOTOR:** the pumps are close-coupled to a carefully matched PEDROLLO electric motor, quiet running, totally enclosed fan cooled (TEFC), suitable for continuous duty.
CPm: single-phase 230 V - 50 Hz with capacitor and thermal overload protector built into the winding.
CP: three-phase 230/400 V - 50 Hz.
- **INSULATION:** class F. ● **PROTECTION:** IP 44.
- **REGISTERED MODEL n° 72753.**

OPTIONS ON REQUEST

- ⇒ impeller in **technopolymer** (CPm...X - CP...X)
- ⇒ special mechanical seal
- ⇒ other voltages or frequency 60 Hz

CURVES AND PERFORMANCE DATA AT n= 2900 1/min

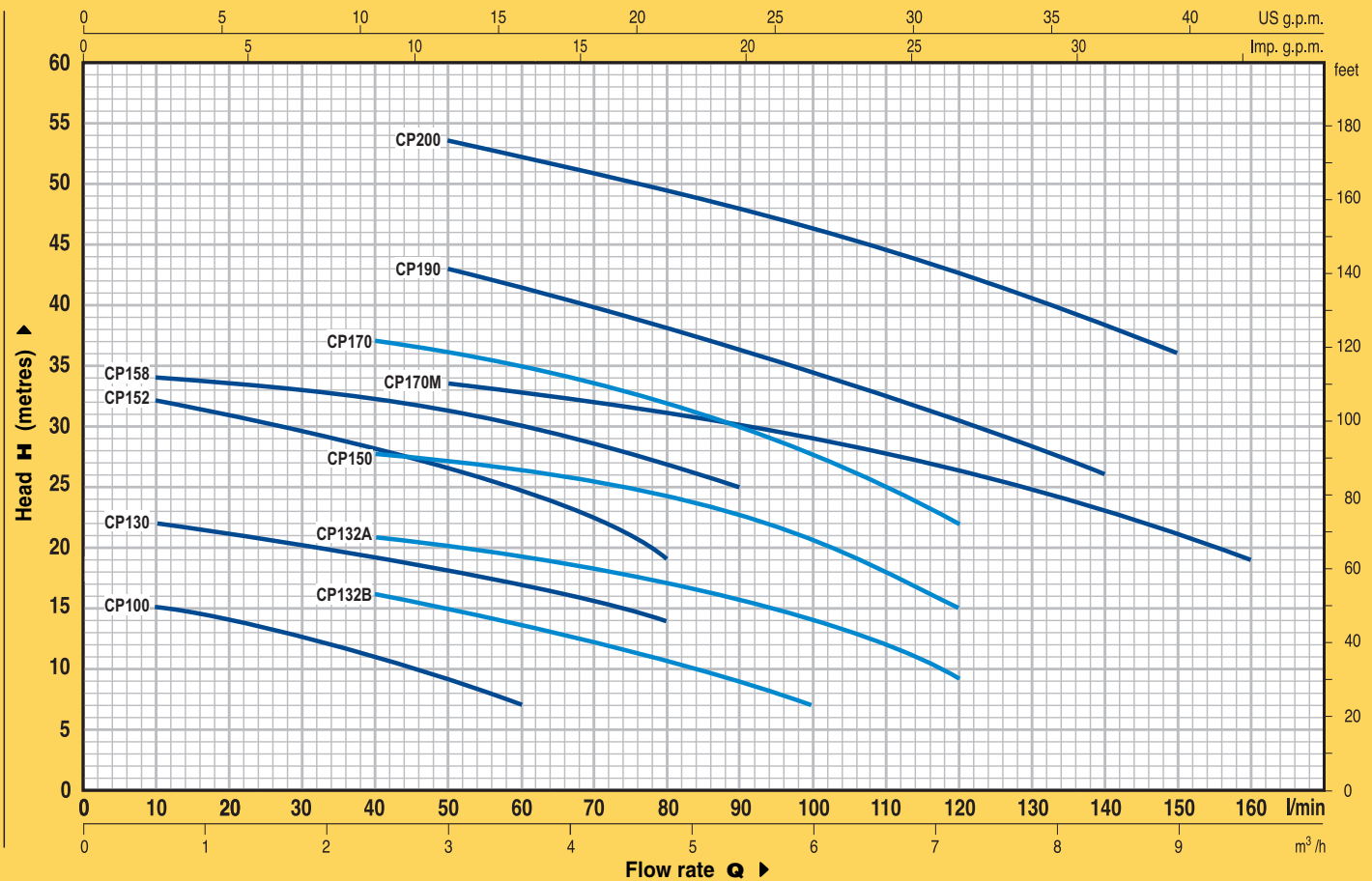

TYPE		POWER		Q	Flow rate																	
Single-phase	Three-phase	kW	HP		m³/h	0	0.6	1.2	1.8	2.4	3.0	3.6	4.2	4.8	5.4	6.0	6.6	7.2	7.8	8.4	9.0	9.6
CPm 100	CP 100	0.25	0.33	l/min	0	10	20	30	40	50	60	70	80	90	100	110	120	130	140	150	160	
CPm 130	CP 130	0.37	0.50	H metres	16	15	14	12.5	11	9	7											
CPm 132B	CP 132B	0.45	0.60		23	22	21	20	19	18	17	15.5	14									
CPm 132A	CP 132A	0.60	0.85		20	—	18	17	16	15	13.5	12	10.5	9	7							
CPm 152	CP 152	0.55	0.75		23	—	22	21.5	21	20	19	18	17	16	14	12	9					
CPm 150	CP 150	0.75	1		33	32	31	29.5	28.5	27	25	23	19									
CPm 158	CP 158	0.75	1		29.5	—	29	28.5	28	27.5	26.5	26	24.5	23	21	18	15					
CPm 170	CP 170	1.1	1.5		36	34	33.5	33	32.5	31.5	30	28.5	27	25								
CPm 170M	CP 170M	1.1	1.5		41	—	—	38	37	36	35	33.5	32	30	27.5	25	22					
CPm 190	CP 190	1.5	2		36	—	—	35	34.5	33.5	33	32	31	30	29	28	26.5	25	23	21	19	
—	CP 200	2.2	3		50	—	—	46	44.5	43	41.5	40	38	36	34.5	32.5	30.5	28	26			
					58	—	—	55	54.5	53.5	52	51	49.5	48	46	44.5	42.5	40.5	38.5	36		

Q = Flow rate H = Total manometric head

Tolerance of the performance curves according to EN ISO 9906 App. A.

DIMENSIONS AND WEIGHTS

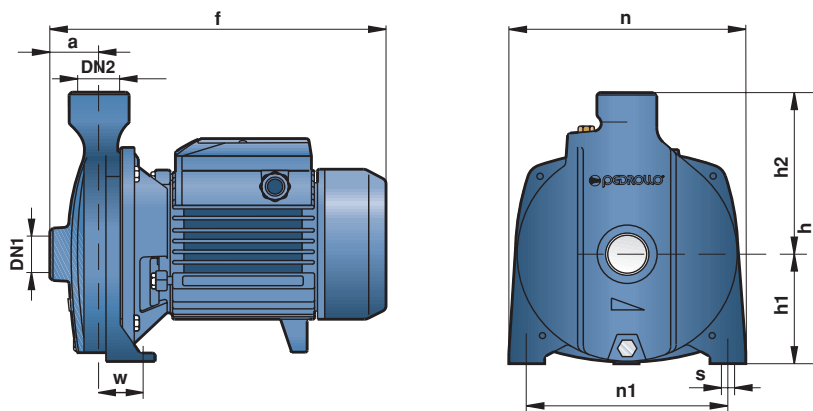

TYPE		PORTS		DIMENSIONS mm								kg					
Single-phase	Three-phase	DN1	DN2	a	f	h	h1	h2	n	n1	w	s	1~	3~			
CPm 100	CP 100	1"	1"	34	247	187	77	110	148	118	45	10	6.8	6.9			
CPm 130	CP 130			42	259	205	82	123	165	135	41		38	7.8	7.6		
CPm 132B	CP 132B													8.0	7.5		
CPm 132A	CP 132A			11/4"	1"	51	367	260	110	150	206		165	44.5	11	8.4	8.1
CPm 152	CP 152															11.5	11.5
CPm 150	CP 150															12.5	11.3
CPm 158	CP 158	11/4"	1"	51	364	290	115	175	242	206	32.5	11	12.1	11.6			
CPm 170-170M	CP 170-170M												19.2	18.5			
CPm 190	CP 190												25.0	24.2			
—	CP 200												-	25.5			