

®

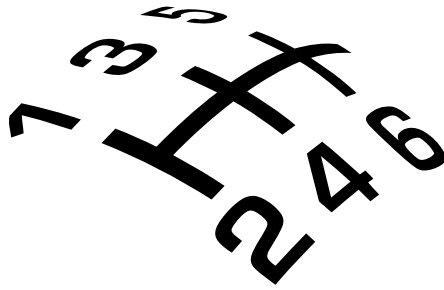

SHORT-SHIFTERS.COM

4H-TECH Short Shifters. **Power shifters for quicker and shorter gear changes**

Fitting guide for I-Shift short shifter.

Removal:

Remove the old complete gearchange linkage from the car. (you can find this on the top of the gearbox at the back) Remove M8 bolt at the back (1), little pin in the joint (4), plastic lever at the top (2), and clips 3 and 5. Take the complete gearchange linkage out of the engine bay.

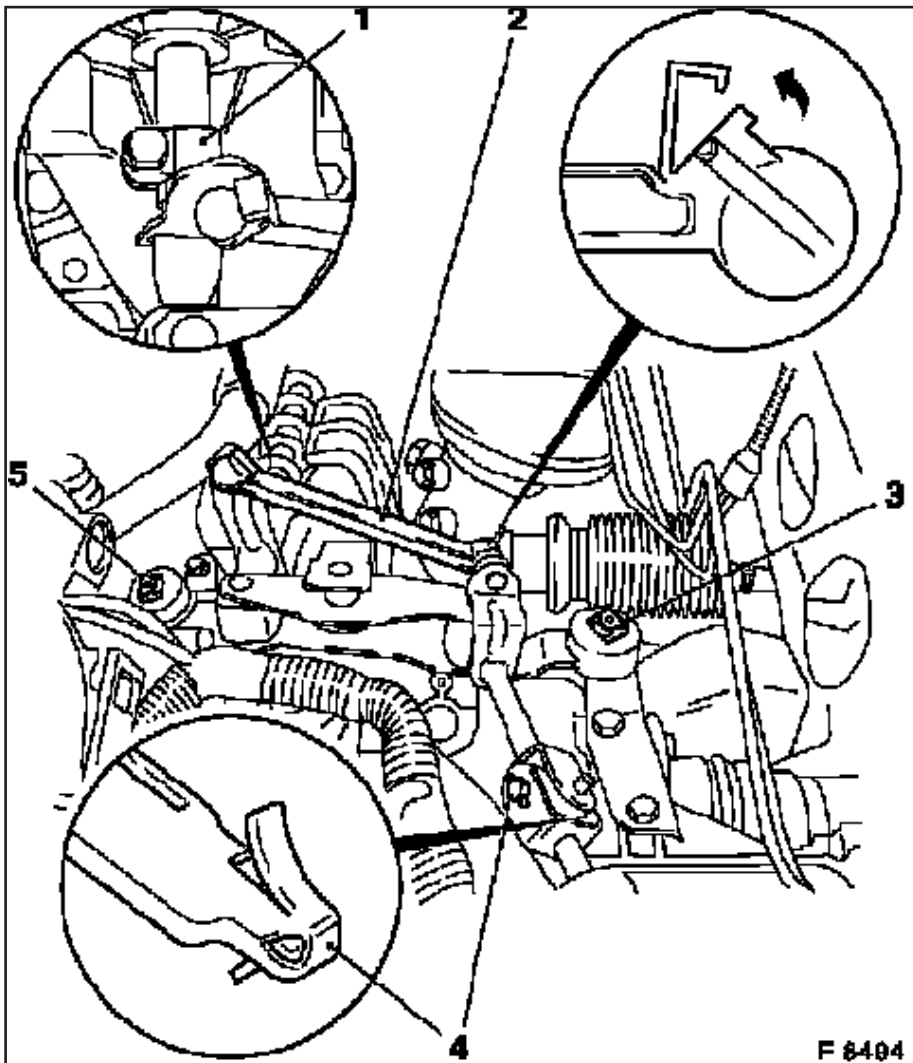



SHORT-SHIFTERS.COM

Take a grinder and flex the top of the pin in the middle flat with the metal surface, till the pin drops out of the joint from below. (See picture)

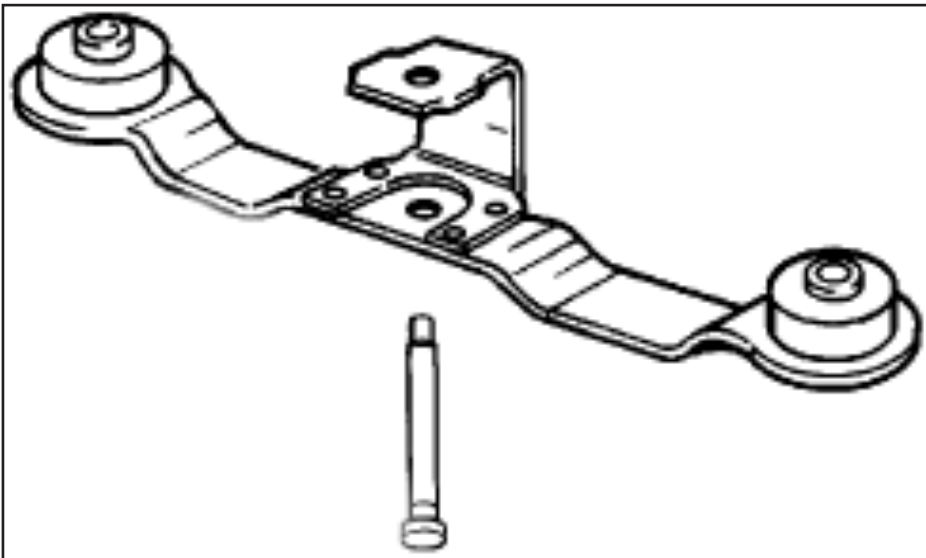
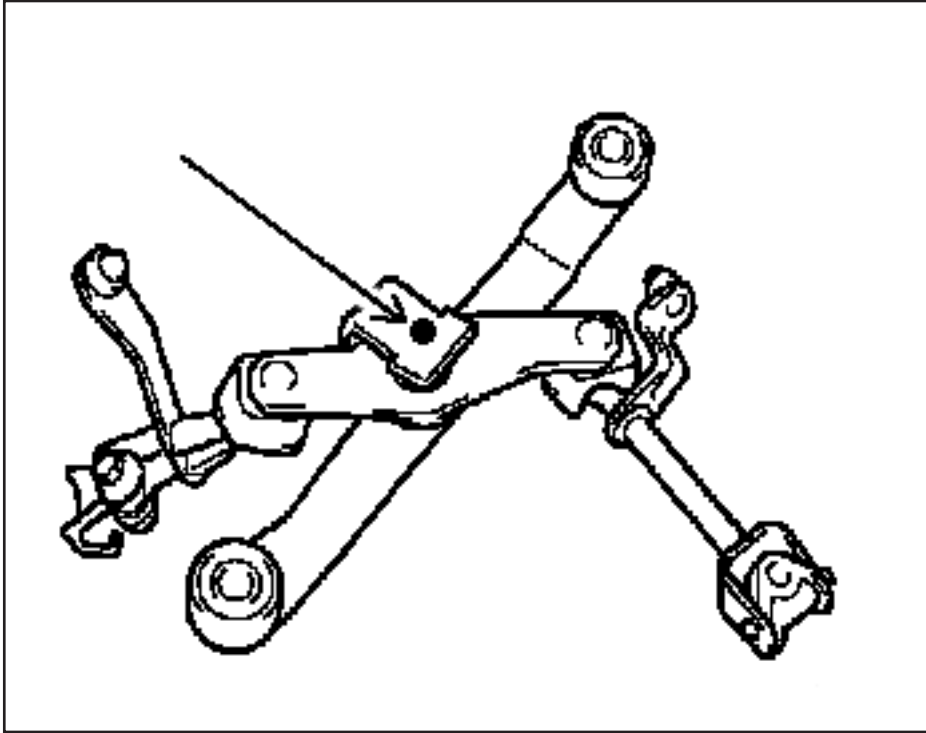

Dismantle the old linkage complete and reassemble every part on the new linkage (shift shortener)

When reassembling , fill everything with silicone grease before fitting to be sure of a smooth gearchange.

Use the extra special bolt and M7 nut to fit the new shortened gearchange linkage.

Refitting:

Mount the new gearchange linkage back in the car. Fit the M8 bolt at the back (1), little pin in the joint (4), plastic lever at the top (2), and clips 3 and 5.



SHORT-SHIFTERS.COM

Adjust the linkage, as follows:

Keep the gears in neutral.

Pull the rubber boot up from the base of the gear lever and move the lever, still in neutral, to the 1st/2nd gear plane. In this position the 2 holes on the stop sleeve and lever housing will be aligned. You can put a 5mm drill through the holes to keep the lever in it's position. (see picture).

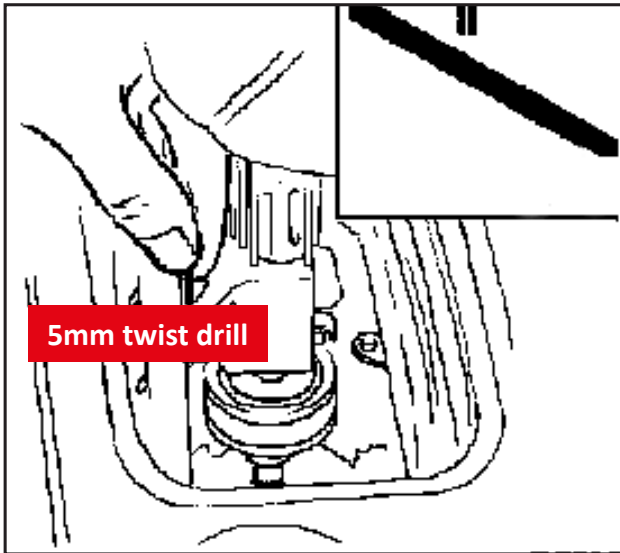

Push the adjustment pin in the gearbox casing. (Turn the selector rod protruding from the selector cover in an anti-clockwise direction (looking towards the front of the car) until the adjustment pin will slide onto it.

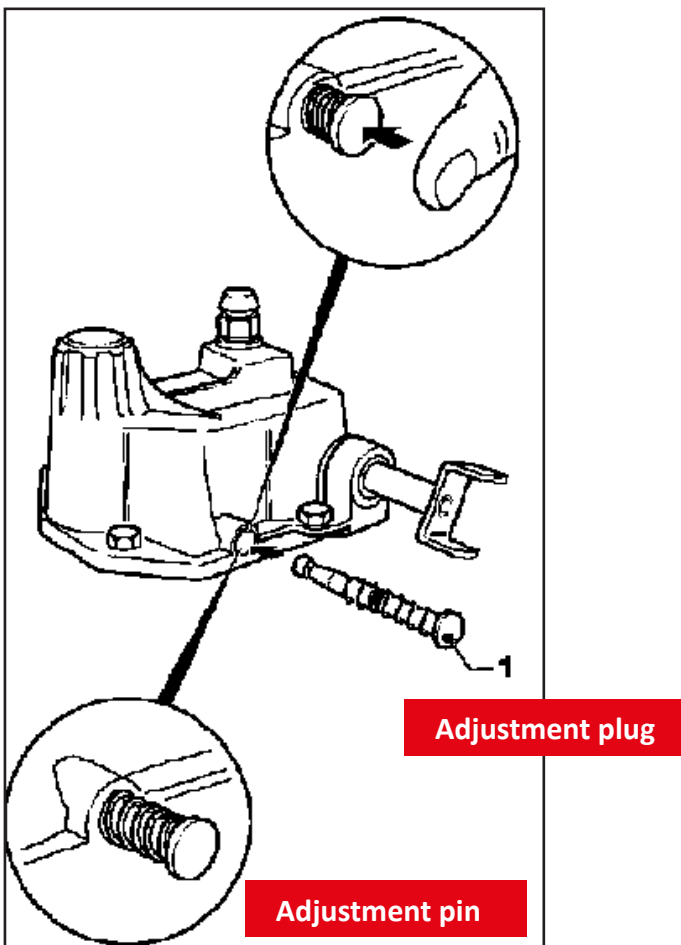



SHORT-SHIFTERS.COM

Tighten the M8 gearchange coupling pinch-bolt in this position.

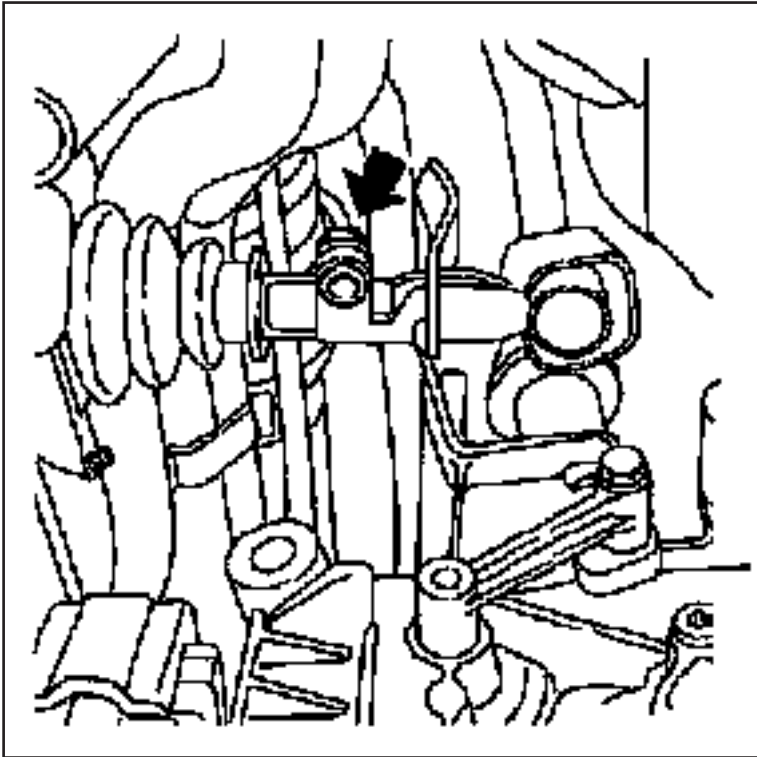

Pull the adjustment pin back out of the casing. Check that all gears can be engaged satisfactorily. Refit the gear lever boot.