



# 953

## INSTALLATION AND USE MANUAL



CE  
Made in Italy

AC 2743/UK - Rev.04 - 05/13

**GEMINI Technologies S.p.A.**

Via Luigi Galvani 12 - 21020 Bodio Lomnago (VA) - Italia

Tel. +39 0332 943211 - Fax +39 0332 948080

[www.gemini-alarm.com](http://www.gemini-alarm.com)

ISO 9001 Certified Company

	Page 2
<b>1.0 - PRELIMINARY ADVICE</b> .....	Page 2
<b>2.0 - USE AND MAINTENANCE</b> .....	
<b>USER MANUAL</b>	
<b>3.0 - ALARM SYSTEM CONTROL DEVICES DESCRIPTION</b> .....	Page 3
3.1 - Remote control.....	Page 3
3.2 - Electronic key.....	Page 4
<b>4.0 - SYSTEM OPERATION - BASIC CONFIGURATION</b> .....	Page 4
4.1 - Arming.....	Page 4
4.2 - Topcase/seat open warning signal.....	Page 4
4.3 - Pre-arm mode.....	Page 4
4.4 - Siren exclusion.....	Page 5
4.5 - Motion sensor exclusion.....	Page 5
4.6 - Full arming.....	Page 5
4.7 - Alarm.....	Page 5
4.8 - Limiting acoustic signals.....	Page 5
4.9 - Neutral time between alarm events.....	Page 6
4.10 - System disarming without alarm memory.....	Page 6
4.11 - System disarming with alarm memory.....	Page 6
<b>5.0 - PROGRAMMABLE FEATURES</b> .....	Page 7
5.1 - Acoustic and optic signals.....	Page 7
5.2 - Remote panic alarm.....	Page 7
5.3 - Shock sensor.....	Page 7
5.4 - Passive arming.....	Page 7
5.5 - Anti-hijack feature.....	Page 8
5.6 - Pre-alarm mode.....	Page 8
5.7 - Self-rearming.....	Page 8
<b>6.0 - SLEEP MODE</b> .....	Page 8
<b>7.0 - HAZARD FEATURE</b> .....	Page 9
<b>8.0 - PIN-CODE OVERRIDE</b> .....	Page 10
<b>9.0 - PIN-CODE OVERRIDE EXAMPLE</b> .....	Page 11/12
<b>10.0 - PIN-CODE CUSTOMIZATION</b> .....	Page 13
<b>11.0 - REPLACING REMOTE CONTROL BATTERIES</b> .....	Page 13
<b>12.0 - WASTE ELECTRICAL AND ELECTRONIC EQUIPMENT (WEEE) DIRECTIVE</b> .....	Page 13

**1.0 - PRELIMINARY ADVICE**

Dear Customer,

Thank you for choosing this Gemini 953 alarm system designed and manufactured in Italy specifically for two-wheeled vehicles.

The present manual includes information for all options available, you may therefore find that some of the information does not apply.

Identify your model and follow the correct directions:

**953:** self-powered, supplied with 2 remote controls and 1 electronic key.

**953.02:** self-powered, supplied with 2 remote controls and snap-in LED indicator.

**952:** not self-powered, supplied with 2 remote controls and snap-in LED indicator.

Please read this manual carefully to familiarize yourself fully with the alarm system features and operating procedures and do keep it handy for future reference.

The following signal words and symbols are included to emphasize important instructions and to alert user/installer to potential hazards:

**⚠ WARNING**

Non-compliance to this instruction could result in serious damage to the vehicle and to the alarm system.

**CAUTION**

Non-compliance to this instruction may cause serious damage or operational failures to the alarm system.

**2.0 - USE AND MAINTENANCE**

Care should be taken to protect the electronic alarm system:

- Do not clean the alarm unit with water but use a damp cloth to wipe.
- Do not use voltages other than the one specified by the manufacturer.
- Protect the alarm from any direct water flow such as high-powered water jets found in a car wash.

**⚠ WARNING**

Gemini Technologies S.p.A. will not be held responsible for any damage caused by improper use.

## USER MANUAL

### 3.0 - ALARM SYSTEM CONTROL DEVICES

The remote controls and electronic key are used to operate the alarm system. A PIN-CODE can also be used to emergency override the system should the remote control be lost or inoperative. Override PIN CODE is entered by means of ignition key (see chapters 8 and 9).

#### 3.1 - REMOTE CONTROL

The remote control has 2 different function buttons each of which corresponds to a control signal that activates a selected action according to the operational condition and alarm configuration.

The textured button is for arming/disarming the alarm while the smooth button is used to exclude or trigger the siren.

The remote control has a low charge battery indicator that gives you early warning to avoid malfunctioning. When the batteries are fully charged, the LED will show a steady light at the press of a button. If the batteries are low, the LED will start blinking when the button is pressed.

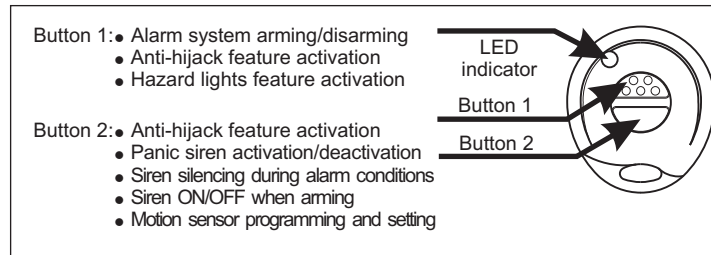

#### 3.2 - ELECTRONIC KEY

The electronic key is a simplified remote control. In emergency situations (ex. in case of remote control failure), it can be used to arm/disarm the alarm or activate/deactivate the anti-hijack feature (if enabled).

To use the electronic key, simply touch it to its receptacle.

The touch receptacle incorporates a LED warning light that serves as both a system status indicator and a visual theft deterrent.

#### Electronic Key Receptacle Positioning

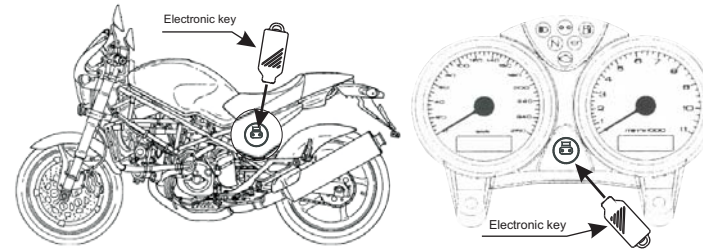

### 4.0 - SYSTEM OPERATION - BASIC CONFIGURATION

#### 4.1 - ARMING

Press remote control button 1 or insert the electronic key into its receptacle to arm the alarm system. Arming is confirmed by a flash of the turn indicators and 2 short beeps. The LED turns ON steady.

#### 4.2 - TOPCASE/SEAT OPEN WARNING SIGNAL

If, during the arming process, the topcase or seat are open or incorrectly closed, a low-tone signal (boop) will sound after the arming confirmation tones.

The alarm will arm but an alarm condition will be triggered after the pre-arm mode.

#### 4.3 - PRE-ARM MODE

After the arming confirmation signals, the LED turns ON steady to indicate the system is in pre-arm mode; it will become fully active after 20".

Engine immobilization and optional module inputs are active during the pre-arm mode.

#### 4.4 - SIREN EXCLUSION

During the first 4" of the pre-arm mode, the alarm siren can be excluded by pressing remote control button 2. The turn indicators will give a quick flash to confirm the siren has been excluded.

#### CAUTION

If the siren is excluded (Mute alarm) only the turn indicators will flash during an alarm event. Engine immobilization will remain enabled.

**NB:** Siren exclusion is bound to each single arming cycle.

#### 4.5 - MOTION SENSOR EXCLUSION

The alarm built-in sensor to detect tilt, motion or a sudden shock can be excluded during the first 4" of the pre-arm time by inserting the electronic key into its receptacle after the alarm system is armed. The status LED will blink once to confirm the sensor has been excluded.

**NB:** Sensor exclusion is bound to each single arming cycle.

#### 4.6 - FULL ARMING

After the 20" pre-arm time, the alarm system is fully armed and ready to detect any irregularity. The LED will start blinking to confirm the armed condition.

#### 4.7 - ALARM

If an alarm condition is detected during the armed state, the siren will sound, the LED will turn ON steady and the turn indicators will flash repeatedly for approx. 30 seconds.

The following irregularities will trigger an alarm if the relative sensors are activated:

- Cable cut tamper detection;
- Ignition attempt (positive under key);
- Motion detection (ex. lifting, towing, forcing the steering lock);
- Seat/topcase unauthorized access (if protected by a contact switch );
- Panic siren ( remote control button 2).

When the alarm condition ceases, the system returns in armed mode. To interrupt the siren and the flashing indicators during an alarm condition, without disarming the alarm, press remote control button 2.

#### 4.8 - LIMITING ACOUSTIC SIGNALS

Each alarm event caused by unauthorized movement, seat/topcase opening or ignition attempt will trigger the siren for 7 consecutive cycles.

The siren will then be automatically excluded for the following reasons:

- To comply with the regulations in force aimed at limiting noise pollution;
- To save power and maximize vehicle battery life;
- If, after 7 cycles, no one checks the vehicle, it is useless to have it sound again.

#### 4.9 - NEUTRAL TIME BETWEEN ALARM EVENTS

When the alarm cycle is over, any further alarm event will be ignored for 5 seconds; the LED will be ON steady.

During neutral time, the system can be disarmed by PIN CODE (see chapters 8 and 9).





#### 4.10 - SYSTEM DISARMING WITHOUT ALARM MEMORY

Press remote control button 1 or insert the electronic key in its receptacle to disarm the alarm system. The LED will turn OFF and disarming will be confirmed by 3 beeps and 3 flashes of the turn indicators.

#### 4.11 - SYSTEM DISARMING WITH ALARM MEMORY

If an alarm event has occurred while you were away from your vehicle, it will be signalled by 2 flashes of the turn indicators and 2 low-tone beeps.

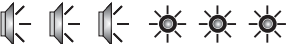
The last cause of alarm can be identified as follows by observing the status LED:

<b>Motion sensor alarm:</b>	
<b>Ignition attempt alarm:</b>	
<b>Topcase/seat alarm:</b>	
<b>Cable cut alarm:</b>	

### 5.0 - PROGRAMMABLE FEATURES

The alarm system is factory preset with some features enabled and others disabled. The shock sensor is preset to be at minimum sensitivity.

<i>Factory setting</i>	
<i>Feature</i>	<i>Status</i>
Acoustic signals	Enabled
Panic siren	Enabled
Motion sensor	Enabled
Passive arming	Disabled
Anti-hijack	Disabled
Pre-alarm	Disabled
Self-rearming	Disabled

### 5.1 - ACOUSTIC AND OPTICAL SIGNALS

Optical signals (turn indicators and status LED) and acoustic signals (siren) indicate arming/disarming, alarm memory, system programming and learning of new devices. Acoustic signals can be disabled.

### 5.2 - REMOTE PANIC SIREN

For use in emergency situations. Panic alarms can be triggered as many times as necessary but at least 5" must elapse between two consecutive alarms. Pressing button 2 will immediately activate the siren and the turn indicators for approx. 30 seconds. To deactivate the panic siren simply press button 2 again. The panic siren can be activated with either an armed or disarmed system.

### 5.3 - SHOCK SENSOR

The built-in sensor with adjustable sensitivity will trigger an alarm whenever it detects tilt, motion or a sudden shock to the vehicle.

### 5.4 - PASSIVE ARMING

The system can be programmed to automatically arm every time ignition is turned OFF, making sure the vehicle won't be left unprotected.

When ignition is turned OFF the turn indicators will flash once, the status LED twice and the siren will chirp 2 times to indicate the system is in pre-arm mode.

The system fully arms (passive arming) 35" after ignition is turned OFF. A flash of the turn indicators and 2 beeps will confirm the system is armed. The LED will turn ON steady.

Lifting the seat or opening the topcase (if protected by a contact switch) during the 35" pre-arming time will cause the procedure to interrupt; it will resume once the seat or topcase are closed.

To interrupt passive arming, turn ignition ON within 35" of turning it OFF.

### 5.5 - ANTI-HIJACK FEATURE

This feature allows the user to remotely switch off the motorcycle engine in case of a hijack attempt.

To activate the anti-hijack while the engine is running, either:

- Press remote control button 1, or
- Press remote control button 2, or
- Insert the electronic key in its receptacle.

Two quick flashes of the turn indicators will confirm activation and the LED will turn ON steady.

#### **CAUTION**

Once the anti-hijack is activated, the remote controls will be inoperative.

The system will cause the motorcycle engine to be cut off 20" after activation. Two seconds later the siren will go off continuously for 1 minute and the turn indicators will start blinking repeatedly until the anti-hijack is disabled. To deactivate anti-hijack insert the electronic key in its receptacle.

### 5.6 - PRE-ALARM MODE

During an alarm event, the siren will only go off for 2.5 seconds (rather than for the standard 30 sec.). The pre-alarm mode is only activated for the first 3 alarm events, from the 4th detection the siren will sound for the full 30 sec. sequence. The pre-alarm feature helps preserve battery life and reduce noise pollution. Alarm cycles will be reset every time the alarm is disarmed or whenever the panic alarm is activated.

### 5.7 - SELF-REARMING

When the system is armed and then accidentally disarmed, the system will automatically rearm 35" after it has been unintentionally disarmed. The standard acoustic and optical signals will confirm activation.

## **6.0 - SLEEP MODE**

If the vehicle will be sitting idle for a period of time, the alarm can be switched off (sleep mode) to preserve battery life.

To activate the Sleep mode feature, proceed as follows:

- Turn ignition key "ON"; the LED will light up for approx. 1".
- Within 4" of the LED flash, insert the electronic key into its receptacle; a beep will confirm the alarm system has been turned OFF.
- Turn ignition key "OFF".
- To re-arm the alarm system, turn ignition key "ON" and then "OFF".

## **7.0 - HAZARD FEATURE**

To make the turn indicators flash as hazard warning lights proceed as follows:

- Turn ignition key "OFF".
- Then turn ignition key "ON"; the LED will light up for approx. 1 second.
- While the LED is ON, press remote control button 1.
- Turn ignition key "OFF"; the turn indicators will start flashing.
- To disable flashing, turn ignition key "ON" (and eventually "OFF") or arm the system.

## 8.0 - PIN-CODE OVERRIDE

If you cannot disarm the system from the remote control or with the electronic key (remotes are lost or broken or batteries are flat), you will be able to disarm the system by using the PIN override procedure. Override PIN code is entered by means of ignition key.

For security reasons, we recommend that you change the PIN code from the factory default setting 1-1-1-1 (see chapter 10). It can be set to any number between 1 and 9.

To override the system:

- Trigger an alarm condition; as soon as the alarm ceases, the status LED will turn ON steady for approx. 5".
- While the LED is ON steady, turn ignition key "ON" and then "OFF".

### CAUTION

If the ignition key stays in the "ON" position for more than 5", the system will interpret the situation as a theft attempt and therefore trigger another alarm.

- The status LED will turn OFF to confirm the system is in disarm mode.
- 4" after the LED has turned OFF, it will start flashing a series of 9 blinks.
- At the number of flashes equal to the PIN CODE 1st digit, turn ignition key ON and OFF. This will confirm the entered digit.
- After 4", the LED will flash again 9 times.
- When the number of flashes is equal to the PIN-CODE 2nd digit, turn ignition key ON and OFF.
- Repeat the above steps for the remaining two digits.
- If the code has been entered correctly, the system will disarm and indicate the last cause of alarm as indicated in paragraph 4.11 "System disarming with alarm memory".

### CAUTION

If the LED blinks more than 9 times, the procedure will be invalidated and considered a theft attempt.

## 9.0 - PIN-CODE OVERRIDE EXAMPLE

To help you understand the override procedure by PIN-CODE, here below is a step-by-step example entering PIN-CODE 2-3-4-1.

Arm the system, wait for the end of pre-arm time and then generate an alarm condition.

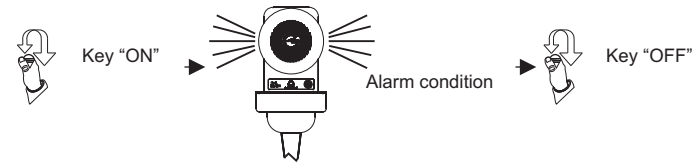

When the alarm condition ceases, the status LED turns ON steady for approx. 5". While the LED is ON, turn ignition key "ON" and "OFF"; the LED will turn OFF to confirm the system is in PIN CODE disarm mode.



The LED will start blinking 4" after turning OFF. Count the flashes and turn ignition key "ON" and "OFF" when the number of flashes equals the PIN-CODE 1st digit (in this case '2').

After 4" the LED will start blinking again.

Count 3 blinks (3rd digit) and turn ignition key "ON" and "OFF".

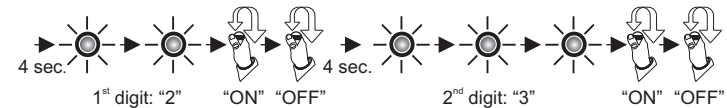

After another 4" the LED will blink again. Turn ignition key "ON" and "OFF" when the number of flashes equals the other 2 digits (4 and 1).

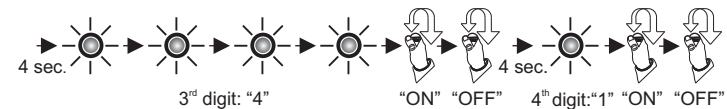

If the PIN CODE has been entered correctly, the alarm system will disarm and indicate the last cause of alarm.

## 10.0 - PIN-CODE CUSTOMIZATION

Here below is a step-by-step example showing how to customize the PIN-CODE. In this case the selected PIN-CODE is **2-3-4-1**.

Disarm the alarm system.

Ground the BROWN/GREEN wire. Open the seat (if protected by a contact switch).

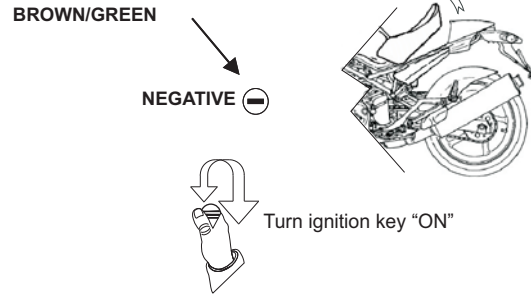

The status LED will light up for 0.5 seconds. While the LED is ON, simultaneously press both buttons on the remote control. The alarm will beep twice and the LED will turn ON steady.

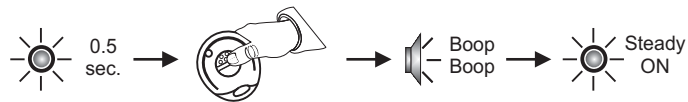

Remove the BROWN-GREEN wire from negative. Close the seat (if protected by a contact switch).

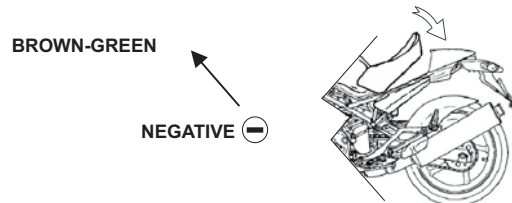

Press both buttons at the same time. The LED will turn OFF.

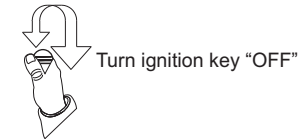

After 4 seconds, the LED will flash 9 times. Count the flashes and turn ignition key "ON" and "OFF" when the number of flashes equals the new PIN-CODE 1st digit.

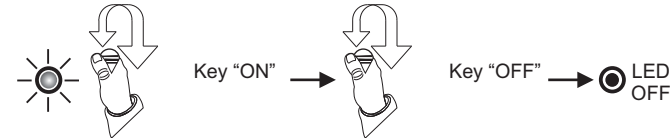

After 4", the LED will flash again 9 times. Repeat the above steps to enter the 2nd digit.

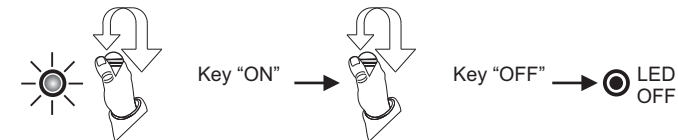

Repeat the above steps to enter the last two digits. When the 4th digit is entered, the system automatically exits the procedure. Two low tone acoustic signals and a high tone signal will confirm the code has been entered successfully.

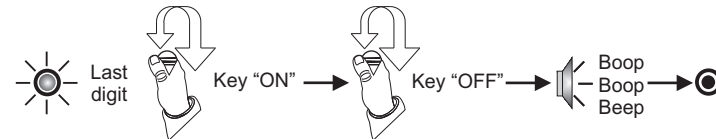

### 11.0 - REPLACING REMOTE CONTROL BATTERIES

The remote control operates using alkaline batteries. When the batteries are too weak, replace them as follows:

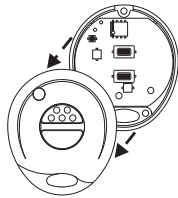

Separate the remote halves taking care not to damage the internal circuit.

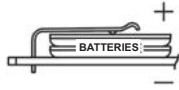

Remove the discharged batteries and insert the new ones taking care not to invert the battery polarity.

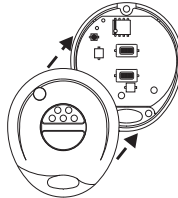

Close the remote halves and make sure it works properly.

#### ⚠ WARNING

Use only **CR1616** batteries.  
Different type batteries can seriously damage the remote control unit.  
Discard used batteries properly in special dedicated containers.

### 12.0 - WASTE ELECTRICAL AND ELECTRONIC EQUIPMENT (WEEE) DIRECTIVE

The present device does not fall within the scope of Directive 2002/96/EC on Waste Electrical and Electronic Equipment (WEEE) as specified in art. 2.1 of L.D. no. 151 of 25/07/2005.

### 13.0 - TECHNICAL SPECIFICATIONS

Power supply	12 Vdc
Supply voltage range	9Vdc-15Vdc
Current absorption @ 12Vdc	<0,7mA (system armed and LED flashing)
Current absorption in sleep-mode	< 1µA
Siren sound level	118 dBA @1 meter
Relay capacity	8A

### R&TTE Declaration of Conformity Doc ref. No. 2010-01

We, the undersigned,

Company	GEMINI TECHNOLOGIES S.p.A
Address, City	Via Luigi Galvani 12, 21020 Bodio Lomnago (VA)
Country	Italy
Phone number	+39 0332 943211
Fax number	+39 0332 948080

Declare under our sole responsibility that the following equipment:

Product description / Intended use	Remote control at 433,92 Mhz for vehicle alarm system
EU / EFTA member states intended for use	EU: all members EFTA: all members
Member states with restrictive use	None
Manufacturer	GEMINI TECHNOLOGIES S.p.A.
Brand name	GEMINI
Type / Model	7208E and 7218E

Is tested to and conforms with the essential requirements as mentioned in Art. 3.1 (a) for protection of Health and Safety of the user and any other person and in Art. 3.1 (b) for Electromagnetic Compatibility, as included in the following standards:

Art. of Directive	Standard	Date of issue of the standard
3.1 (a) Health	EN 50371	2002
3.1 (a) Safety	EN 60950-1 +A11	2006; 2009
3.1 (b) EMC	EN 301 489-3	V2.1.1 (2009-05)
3.1 (b) EMC	EN 301 489-1	V1.8.1 (2008-04)

And is tested to and conforms to Art. 3.2, with the essential radio test suites so that it effectively uses the frequency spectrum allocated to terrestrial/space radio communication and orbital resources so to as avoid harmful interference, as included in following standards:

Art. of Directive	Standard	Date of issue of the standard
3.2 Spectrum	EN300 220-2	V2.3.1 (2010-02)

And therefore complies with the essential requirements and provisions of the **Directive 199/5/EC** of the European Parliament and of the council of March 9, 1999 on Radio Equipment and Telecommunications Terminal Equipment and the mutual recognition of their conformity and with the provisions of Annex II.



TCF reference nr.	TCF_7208E/7218E
Date	August 23, 2010
Name and position	Andrea Rossi, General



## INSTALLER MANUAL

### CONTENTS

<b>1.0</b> - PRELIMINARY ADVICE.....	Page 15
<b>2.0</b> - ALARM UNIT POSITIONING.....	Page 16
<b>3.0</b> - ALARM UNIT SEALING.....	Page 17
<b>4.0</b> - ACCESSORIES POSITIONING.....	Page 18
4.1 - Receptacle for electronic key and LED indicator.....	Page 18
4.2 - Contact switch (optional).....	Page 18
<b>5.0</b> - ELECTRICAL CONNECTIONS.....	Page 19
<b>6.0</b> - WIRING DIAGRAM.....	Page 20
<b>7.0</b> - ENGINE IMMOBILIZATION CONNECTION DIAGRAM (ground wire).....	Page 21
<b>8.0</b> - ENGINE IMMOBILIZATION CONNECTION DIAGRAM (cut wire).....	Page 22
<b>9.0</b> - EXAMPLE OF ENGINE IMMOBILIZATION CONNECTION WITH SPECIFIC WIRING HARNESS.....	Page 23/24
<b>10.0</b> - ELECTRICAL CONNECTIONS WITH SPECIFIC WIRING HARNESS.....	Page 25
10.1 - Engine immobilization connections.....	Page 25
10.2 - Turn indicator connections.....	Page 25
10.3 - Ground connection.....	Page 25
10.4 - Electronic key receptacle with built-in LED.....	Page 25
<b>11.0</b> - DIODE INSTALLATION.....	Page 26
<b>12.0</b> - LEARNING NEW DEVICES (with ground wire).....	Page 27
<b>13.0</b> - LEARNING NEW DEVICES (without ground wire).....	Page 28
<b>14.0</b> - PROGRAMMABLE FEATURES.....	Page 29/30
<b>15.0</b> - PROGRAMMING EXAMPLE.....	Page 31
<b>16.0</b> - MOTION SENSOR ADJUSTMENT.....	Page 32

### 1.0 - PRELIMINARY ADVICE

**Please read all instructions and understand them thoroughly before starting installation.**

### 2.0 - ALARM UNIT POSITIONING

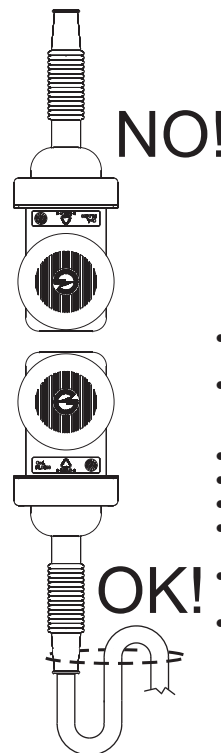

Do not install the alarm unit in this position as water ingress over time may seep through the rubber sheath and permanently damage the electronic circuit making the alarm system unreliable. Eventual malfunctioning due to water infiltration is not covered by warranty.

- Fitting the control unit in this position, will prevent water entering the unit.
- It is important to give the rubber sheath a 'goose-neck' bending as shown in the picture opposite and secure with a tie wrap.
- Do not expose to atmospheric agents.
- Pay attention not to muffle the siren speaker.
- Secure away from moving mechanical parts.
- Keep away from devices that could generate high frequency electromagnetic disturbances.
- Keep away from devices that could reach high temperatures when the vehicle is in use.
- Do not secure the control unit directly on the vehicle frame.

#### CAUTION

If a jet wash is used to clean the vehicle, protect the alarm unit from water splashes and be careful not to expose it to high pressure jets. The warranty will not cover damages to the system due to water infiltrations caused by improper installation, jet washing or the use of non original accessories, not approved by the manufacturer.

### 3.0 - ALARM UNIT SEALING

To seal the alarm, position the rubber cap over the external edge of the alarm housing as shown below.

Pull the plastic rectangular flange over the rubber cap and secure with the supplied screws. Do not over tighten the screws.

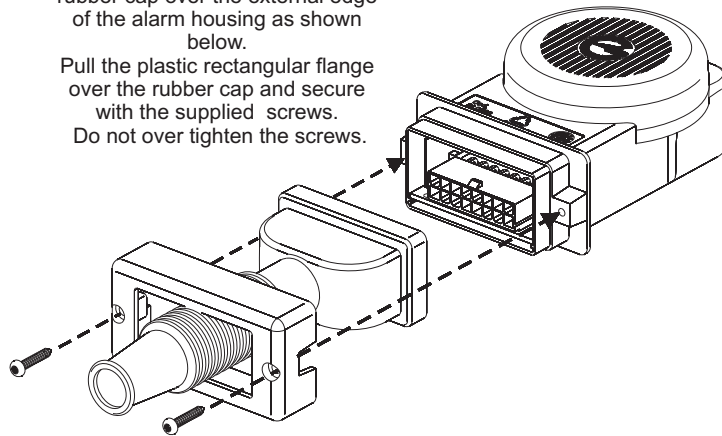

Alarm unit sealed

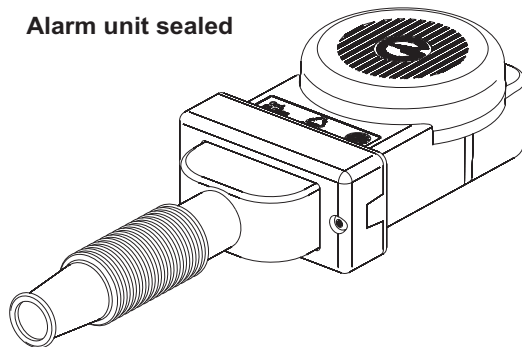

### 4.0 - ACCESSORIES POSITIONING

#### 4.1 - RECEPTACLE FOR ELECTRONIC KEY AND LED INDICATOR

The receptacle with built-in LED (or the LED) must be installed where it can readily be seen and accessed by the user. The LED warning light serves as both a system status indicator and a visual theft deterrent.

Always check for rear clearance before drilling. If drilling a hole in the plastic dash, check the position of the handlebars with the steering lock engaged. Make sure the LED will not be covered by the handlebars when the vehicle is parked.

Drill size for the electronic key receptacle: 13mm.

Drill size for the LED indicator: 10mm.

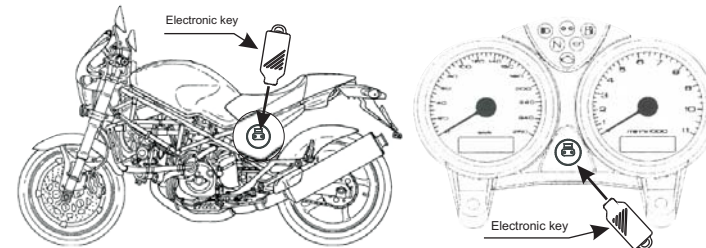

#### 4.2 - CONTACT SWITCH (OPTIONAL)

A contact switch can be fitted to protect the seat or topcase. It must be installed in such a way as to detect the opening of the seat/topcase without being accessible from the outside. The trigger threshold must be carefully set to avoid false alarms.

Do not ground the switch terminal to the vehicle frame as it might not be connected to the battery negative pole. Connect to a cable that provides continuous ground such as the indicator lamp negative lead.

**NB:** If no contact switch is fitted, the GREEN/BROWN wire will remain free for other possible uses.

## 5.0 - ELECTRICAL CONNECTIONS

### CAUTION

The tables below refer to the standard wiring harness (KITCA 417).  
For a complete list of model-specific wiring harnesses, please visit:  
[www.gemini-alarm.com](http://www.gemini-alarm.com) (private area).

Pos.	Wire colour	Wire function
- 1 -	Brown	Electronic key ground
- 2 -	Brown	Ground
- 3 -	White-Violet	Device learning push-button input
- 4 -	Green-Brown	Contact switch input
- 5 -	---	Not applicable
- 6 -	---	Not applicable
- 7 -	Yellow	Ignition
- 8 -	Black	LED negative output
- 9 -	Green	Electronic key input
- 10 -	Grey	Engine cut (N.C.)
- 11 -	White	Engine cut (Com.)
- 12 -	White-Grey	Engine cut (N.O.)
- 13 -	Orange	Turn indicators
- 14 -	Red	Positive
- 15 -	Orange	Turn indicators
- 16 -	Black	Antenna

### ENGINE CUT-OFF - cut wire

Wire colour	Connection
White	Connect to ignition key switch cut end
Grey	Connect to vehicle electric system cut wire

### ENGINE CUT-OFF - grounded wire

Wire colour	Connection
White	Connect to vehicle continuous negative (do not connect to vehicle frame)
White/Grey	Connect to the cable end which, if earthed, will cut the engine

## 6.0 - WIRING DIAGRAM

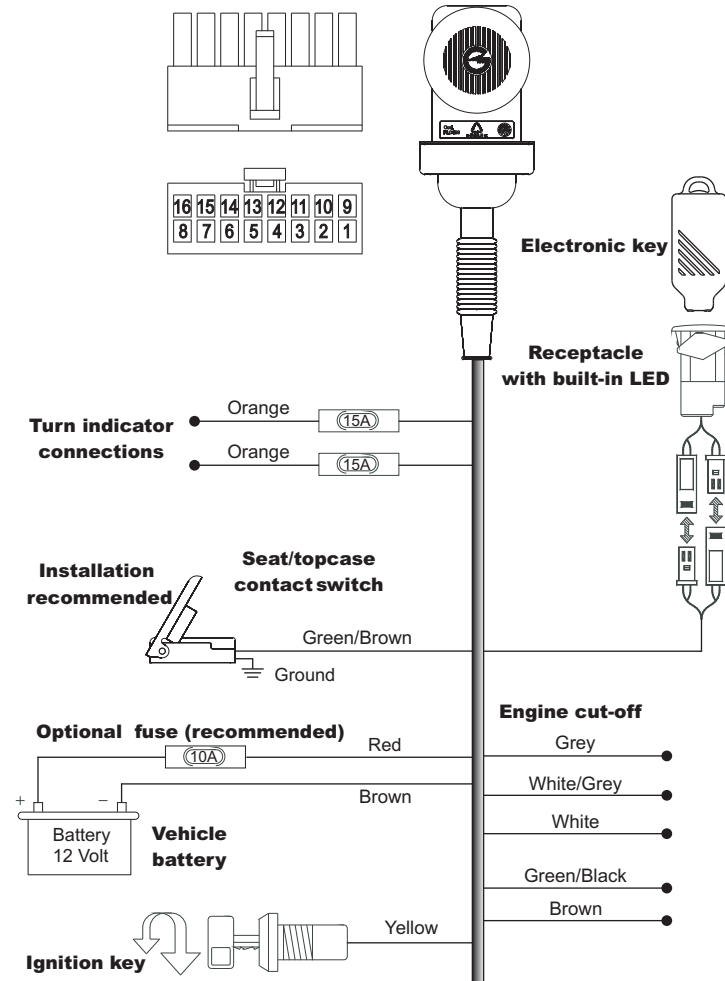

**7.0 - ENGINE IMMOBILIZATION CONNECTION DIAGRAM**

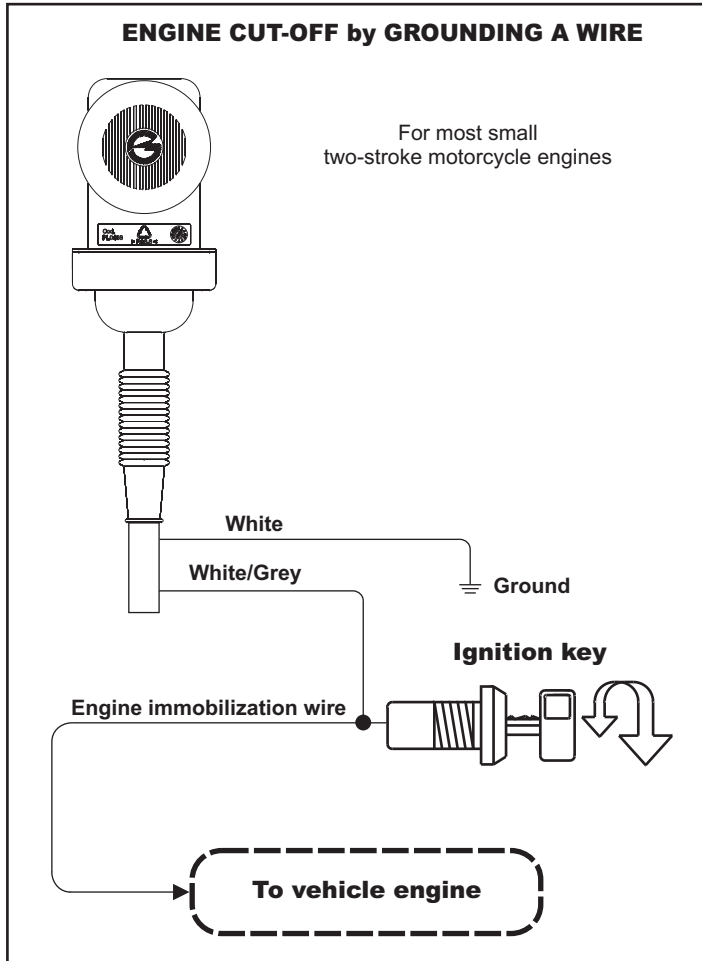

**8.0 - ENGINE IMMOBILIZATION CONNECTION DIAGRAM**

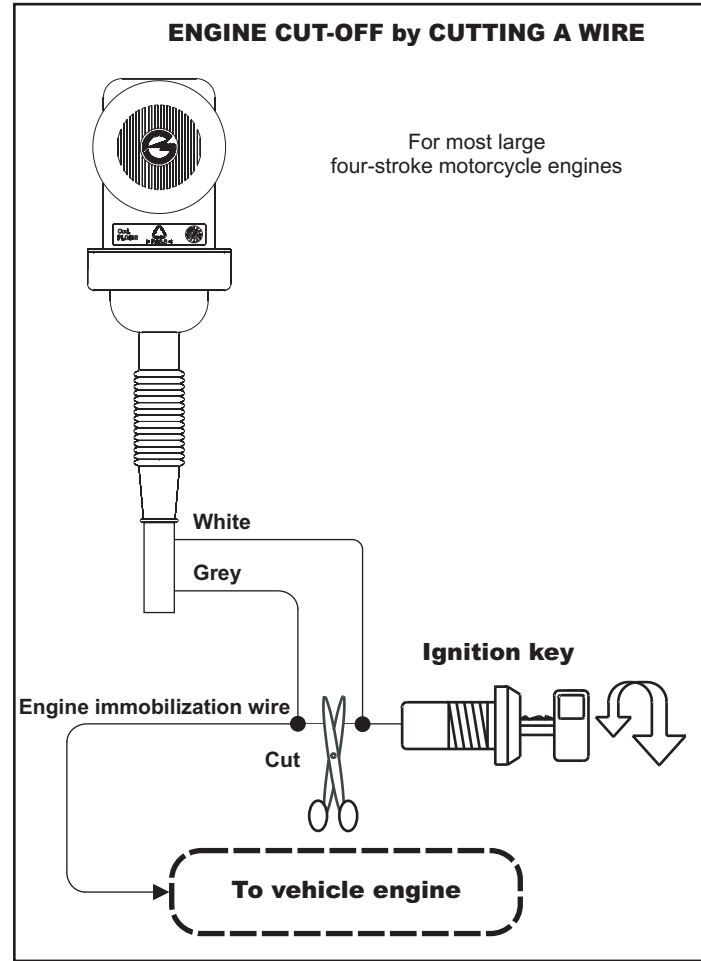

**9.0 - EXAMPLE OF ENGINE IMMOBILIZATION CONNECTION WITH SPECIFIC WIRING HARNESS**

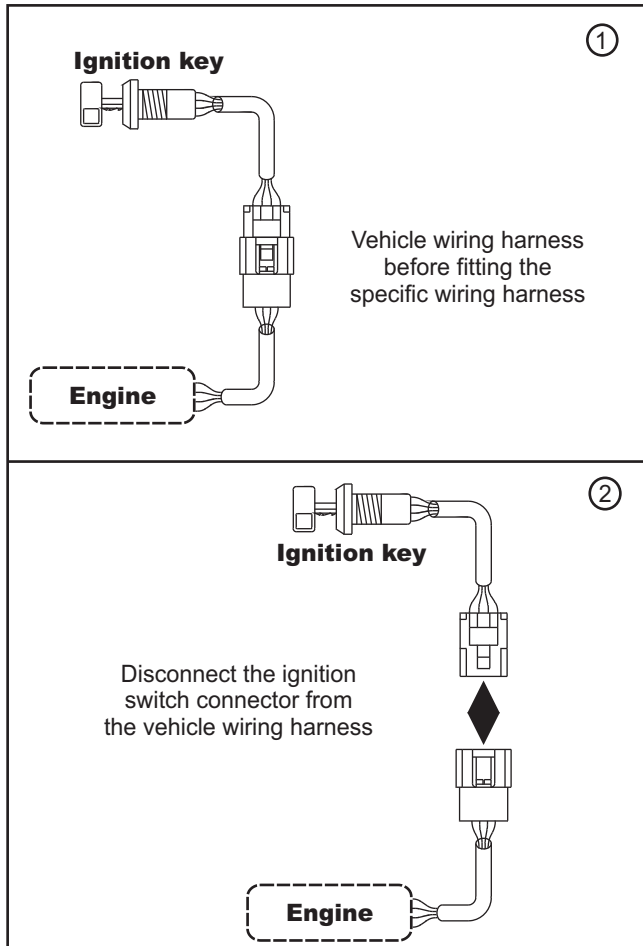

**9.0 - EXAMPLE OF ENGINE IMMOBILIZATION CONNECTION WITH SPECIFIC WIRING HARNESS**

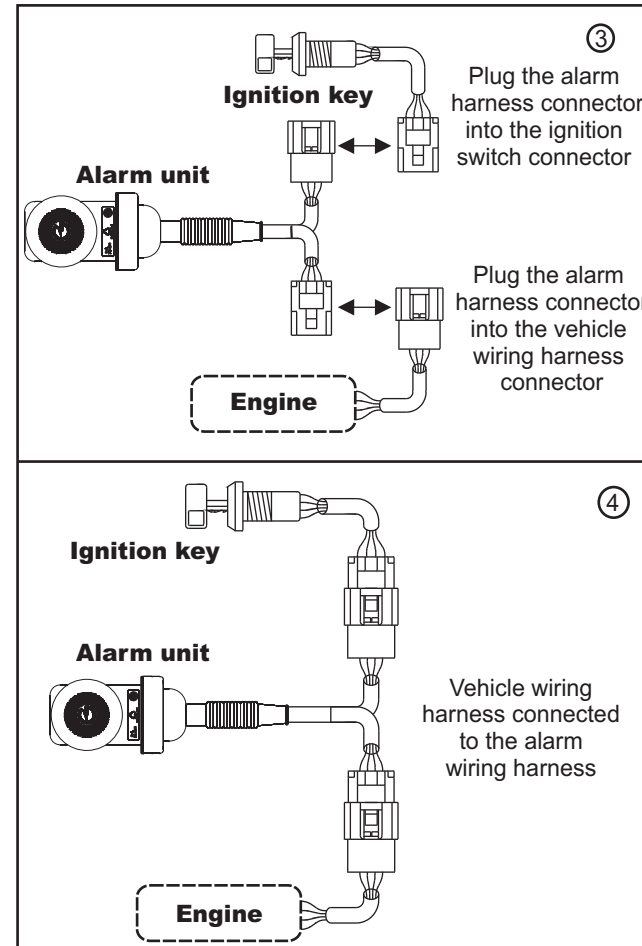

## 10.0 - ELECTRICAL CONNECTIONS WITH SPECIFIC WIRING HARNESS

After selecting the appropriate position for the alarm system and accessories (electronic key receptacle, seat/topcase contact switch), proceed with the electrical connections.

Pay special attention to the following instructions in order to ensure proper electrical connections and refer to the relative drawings.

### 10.1 - ENGINE IMMOBILIZATION CONNECTIONS

- Disconnect the ignition switch connector (or the factory installed device for engine immobilization) from the vehicle main wiring harness connector (fig.2).
- Insert the alarm harness connectors as follows: one into the ignition switch connector (or the factory installed immobilization device) and the other into the vehicle main wiring harness (fig.3).
- Connectors cannot be inverted because they are polarized.

### 10.2 - TURN INDICATOR CONNECTIONS

- Connect the alarm harness wires to the the same color vehicle wires that provide a positive feed to the turn indicator lamps.

### 10.3 - GROUND CONNECTION (WHEN NOT AVAILABLE ON THE IGNITION SWITCH)

- If the vehicle ignition switch does not have a ground wire (ex. four-stroke engine vehicles) the alarm ground wire must be connected to a vehicle ground point (ex. turn indicator negative lead).
- Do not connect the alarm ground cable to the vehicle frame.

### 10.4 - ELECTRONIC KEY RECEPTACLE WITH BUILT-IN LED

Connect the receptacle 2-way BLACK connectors to the relative alarm unit 2-way BLACK connectors.

Wires inside the receptacle connectors are RED and BLACK and they are BROWN and GREEN in the alarm unit connectors.

## 11.0 - DIODE INSTALLATION

Check if a diode needs to be installed on the vehicle:

- Activate one of the turn indicators, turn ignition OFF and arm the alarm.
- If the instrument panel comes on when the turn indicators are activated, a diode needs to be installed (see diagram below).
- If the instrument panel does not light up, do not insert a diode.

### CAUTION

A diode is not really necessary if, when the alarm is armed, the instrument panel comes on.  
No damage will be incurred to the vehicle in case a diode is not fitted.

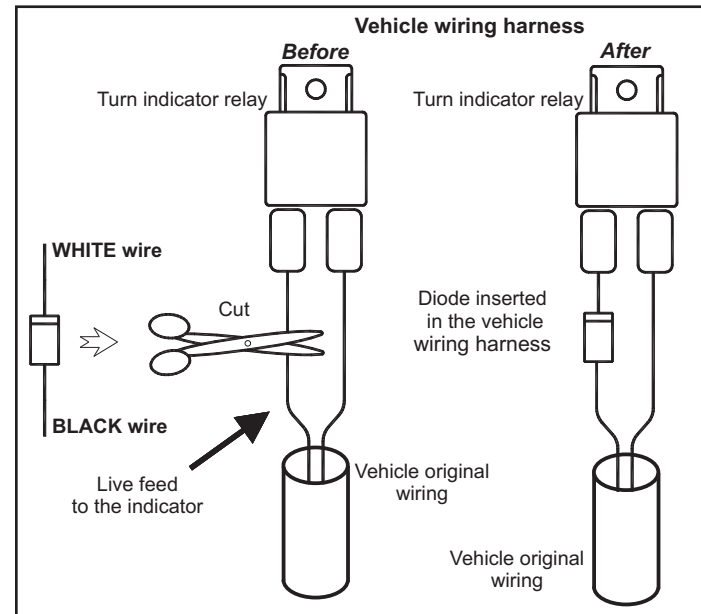

## 12.0 - LEARNING NEW DEVICES (With BROWN/GREEN WIRE GROUND CONNECTION)

The alarm is supplied with 2 remote controls and 1 electronic key but extra optional devices can be added.

To learn a new device, proceed as follows:

- Make sure passive arming feature is disabled.
- Disarm the alarm system via remote control or electronic key.
- Lift the seat or open the topcase or, if no contact switch is fitted, ground the BROWN-GREEN wire.
- Connect the learning button to the relative connector, YELLOW or yellow sheathed.
- Press and hold the learning button.
- Turn ignition key "ON".
- Two flashes of the turn indicators and two beeps, a high and a low tone, will confirm the system is in learn mode.
- Release the button.
- Press one of the buttons on the remote control to be learned or insert the electronic key in its receptacle.
- A flash of the turn indicators and a beep will indicate the new device has been learned.
- If other devices need to be learned, press and release the learning button once again and then press the remote control button or insert the electronic key in its receptacle.
- Turn ignition key "OFF" to exit the procedure, a low-tone beep and a single flash of the direction indicators will confirm the end of the procedure.
- Close the seat or topcase or remove the BROWN/GREEN wire from ground.

### CAUTION

Alarm memory will only store 8 devices.  
Saving an extra device will automatically delete the first one.

## 13.0 - LEARNING NEW DEVICES (Without BROWN/GREEN WIRE GROUND CONNECTION)

The alarm is supplied with 2 remote controls and 1 electronic key but extra optional devices can be added.

To learn a new device, proceed as follows:

Make sure passive arming feature is disabled.

- Disarm the alarm system via remote control or electronic key.
- Turn ignition key "ON".
- The status LED will turn ON for 1".
- While the LED is ON, press both buttons on the remote control simultaneously or insert the electronic key into its receptacle.
- Two flashes of the turn indicators and two beeps, a high and a low tone, will confirm the system is in learn mode.
- Press one of the buttons on the remote control to be learned or insert the electronic key in its receptacle.
- If other devices need to be learned, wait 2" and then press one of the buttons on the remote control or insert the electronic key in its receptacle.
- Turn ignition key "OFF" to exit the procedure.
- A low-tone beep and a flash of the turn indicators will confirm the end of the procedure.





### CAUTION

Alarm memory will only store 8 devices.  
Saving an extra device will automatically delete the first one.

## 14.0 - PROGRAMMABLE FEATURES

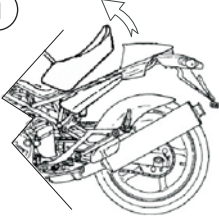
To either enable or disable one of the programmable features proceed as shown below:

**NB: Remember to ALWAYS arm and disarm the alarm before programming.**

<p><b>1</b></p> 	<p>With the alarm system disarmed, lift the seat or open the topcase (if they are protected by a contact switch) otherwise ground the GREEN/BROWN wire. Remove from ground after programming.</p>
<p><b>2</b></p> 	<p>Turn ignition key "ON".</p>
<p><b>3</b></p> 	<p>The LED will light up for approx. 1".</p>
<p><b>4</b></p> 	<p><b>While the LED is ON</b>, simultaneously press the 2 buttons on the remote control. Two beeps (a low and a high tone beep) will confirm the system is in programming mode. The LED will light up steady .</p>

After pressing both buttons simultaneously (step 4), program the features according to your needs.

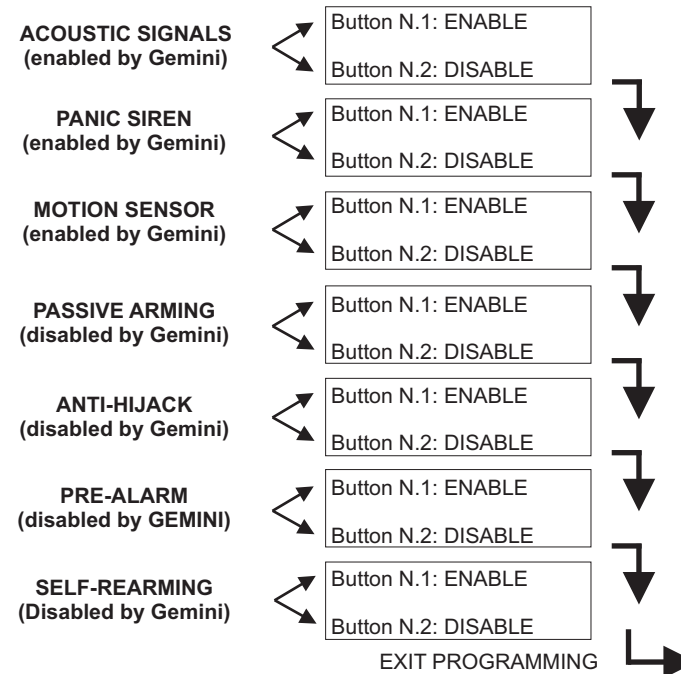
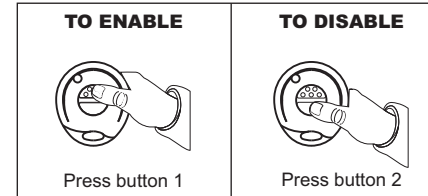



## 15.0 - PROGRAMMING EXAMPLE

To help you understand the programming procedure, here below is an example showing how to activate the acoustic signals, the panic alarm, the shock sensor and the pre-alarm features.

Keep in mind that, at every button press, the system automatically scrolls to the next feature.

- With the system disarmed, lift the seat or topcase (if protected by a contact switch) otherwise ground the BROWN/GREEN wire.
- Turn ignition key "ON"; the LED will turn ON for 1".
- While the LED is ON, simultaneously press the two buttons on the remote control. Two beeps will confirm the system is in programming mode. The LED will light up steady.
- Press button 1; a high tone beep will confirm acoustic signals have been **enabled**.
- Press button 1; a high tone beep will confirm the panic siren has been **enabled**.
- Press button 1; a high tone beep will confirm the motion sensor has been **enabled**.
- Press button 2; a low tone beep will indicate passive arming has been **disabled**.
- Press button 2; a low tone beep will indicate the anti-hijack feature has been **disabled**.
- Press button 1; a high tone beep will confirm pre-alarm has been **enabled**.
- Press button 2; a low tone beep will confirm self-rearming has been **disabled**.
- When the last feature has been enabled or disabled, the system automatically exits the programming procedure. Two low tone beeps followed by a high tone beep will confirm the end of the procedure. The status LED will also turn OFF .
- Turn ignition key "OFF". Close the topcase or seat or remove the BROWN/GREEN wire from ground.

### CAUTION

You can exit the programming procedure at any time by turning ignition key "OFF".  
Programmed features will automatically be saved while the others will remain unvaried.

## 16.0 - MOTION SENSOR ADJUSTEMENT

The alarm system has a built-in shock sensor with 5 levels of sensitivity adjustment. The shock sensor is factory preset to be at minimum sensitivity.

To change the sensitivity level proceed as follows:

- Disarm the alarm system via remote control or electronic key.
- Turn ignition key "ON"; the status LED will turn ON for 1".
- While the LED is ON, press remote control button 2 and, within 2", press it again.

### CAUTION

The procedure will be voided if more than 2 seconds go by between the first button press and the second.

- Two LED flashes and two low tone beeps will confirm the system has entered adjustment mode.
- Press remote control button 2 to increase sensitivity (press 4 times to set at maximum level); there will be a LED flash and a short beep at every button press.
- When the sensor is adjusted, turn ignition key "OFF".
- If adjusted at the highest level, the system automatically exits the procedure.
- In both cases, a LED flash and a low tone beep will confirm the end of the procedure.

### CAUTION

Entering in programming mode resets features to factory default settings.