

TECHNICAL DATA SHEET

Ref. 500010

Unipolar BATTERY

MASTER SWITCH

24VDC / 250A

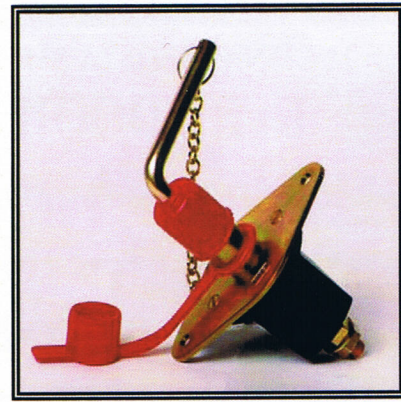

GENERAL CHARACTERISTICS

Protection degree: IP65
Ambient temperature: -40°C to +85°C
Weight: 0.562 Kg approx.
Contacts: Copper
Connections: not polarized

FIELDS OF APPLICATION

Handling vehicles, industrial vehicles,
agriculture machinery, industry...

POWER CIRCUIT

Connection: M10 terminals
Tightening torque: 1.5 +/- 0.1 daN·m
Type: D1 normally open
Nominal current: 250 A
Nominal voltage: 24 VDC
Max. capacity: 2500 A during 5 seconds

PARTICULAR CHARACTERISTICS:

Removable handle with PVC protector

SPARE PARTS

Handle + chain + protector	520020
Handle	520009
Strap + PVC protection	520003

Size diagrams

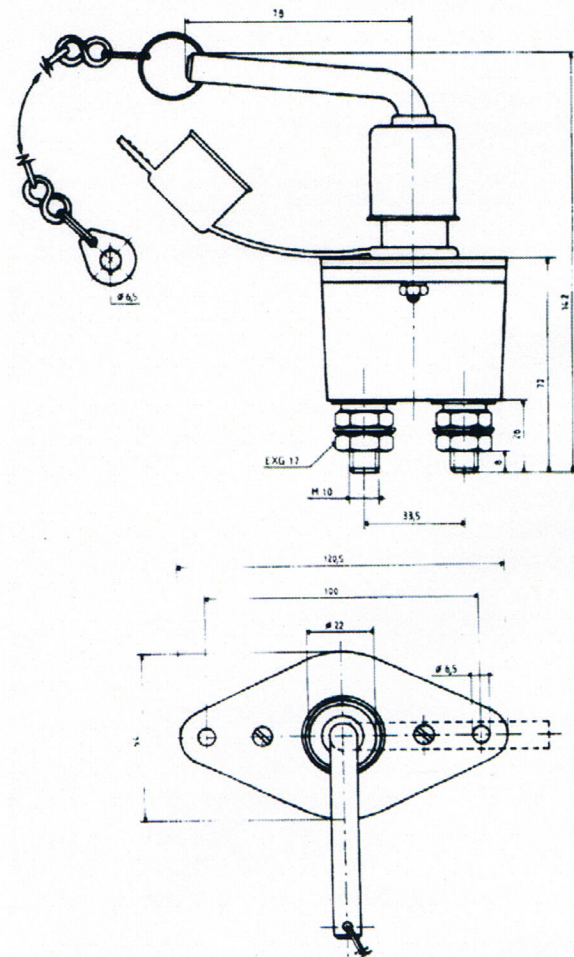

Connection diagram

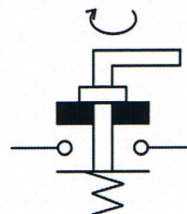

Fixing diagram

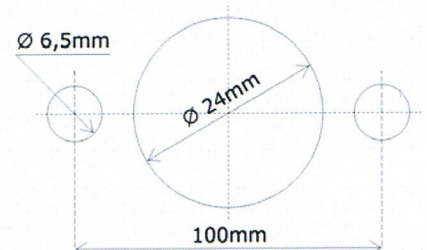

P.I. EL RAÍQUER, C/ EL RAÍQUER, S/N, NAVE Nº21-22
08170 MONTORNÈS DEL VALLÈS
BARCELONA (SPAIN)
TEL. : + 34.93.544.44.80 - FAX : + 34.93.544.44.90
WWW.CORMAR.ES - info@cormar.es