

zibro[®]

made by **TÖYÖTÖMI**

RS – G24



GB	OPERATING MANUAL	PAGE 2
D	GEBRAUCHSANWEISUNG	PAGE 16
F	MANUAL D'UTILISATION	PAGE 30
NL	GEbruIKSAANWIJZING	PAGE 44
E	INSTRUCCIONES DE USO	PAGE 58
I	ISTRUZIONI D'USO	PAGE 72
DK	BRUGERVEJLEDNING	PAGE 86
N	BRUKERINSTRUKSEN	PAGE 100
S	INSTRUKTIONERNA INNAN ANVANDNING	PAGE 114
FIN	KÄYTTÖOHJEET	PAGE 128

Thank you for choosing a "TOYOTOMI" product!

Toyotomi products are used by satisfied customers worldwide. In order to assure the comfortable and safe use of our products by customers in each country, our products conform to the safety standards not only in Japan but also in every country around the world we do business with.

Toyotomi tailors its products to satisfy its customer's needs by always pursuing our business philosophy, "sharing joys in daily living". We will continue to research, develop and manufacture products that match people's lifestyle for efficiency, safety and comfort.

We hope that you'll enjoy your Toyotomi appliance for years to come!

We invite you to read this instruction manual first, to ensure the maximum lifetime for this appliance.

Get to know us better...visit us at www.toyotomi.eu for our full line of products.

1 READ THE DIRECTIONS FOR USE FIRST.

2 IN CASE OF ANY DOUBT, CONTACT YOUR DEALER.

3 BEFORE YOU START READING, CONSULT THE MAIN COMPONENTS LIST ON THE LAST PAGE.

GENERAL DIRECTIONS FOR USE

Below you will find the main steps to be taken for using your heater. For more details, please refer to the MANUAL.

- 1** Remove all packaging materials (*refer to Section A, Fig. A*).
- 2** Fill the removable tank **8** and wait 30 minutes before you ignite the heater (*refer to Section B, Fig. I*).
- 3** Check whether the combustion chamber **3** is fully upright (*refer to Section A, Fig. E*).
- 4** Ignite the heater by turning the knurled wick adjustment knob **2** as far to the right as possible (*refer to Section C, Fig. K*).
- 5** After igniting the heater it will take 30 minutes before you can check if the heater burns well (*refer to Section D*).
- 6** Switch off the heater (*refer to Section E*).

- As a fire precaution, the tank must be filled either when the heater has been switched off or in another room than the room where the heater is installed.
- Always ensure that the tank is closed properly after filling it at a safe distance from all sources of heat and open flames (see Section B).
- Store all fuel containers with their original caps and seals in a cool and dark place.
- Fuel ages. Use new fuel at the start of every heating season.
- Only use high quality and water -free pure paraffin in accordance with local legislation.
- Before changing brands and/or types of fuel make sure that the mobile heater first completely empties all of the remaining fuel inside the heater.
- The first time you ignite your heater it will smell like 'new' for a short time.

WHAT YOU NEED TO KNOW IN ADVANCE

ALWAYS MAKE SURE THAT THERE IS SUFFICIENT VENTILATION

Read this user manual carefully before using the appliance and keep it for future reference. Install this device only when it complies with local/national legislation, ordinances and standards. This product is intended to be used as a heater in residential houses and is only suitable for use in dry locations, in normal household conditions, indoors in living room, kitchen and garage.

For comfortable and safe heating ensure that there is sufficient ventilation.

Note: To avoid unexpected shut off, we recommend to put a door or window ajar when the heater is operating.

For each model the minimum size of space is specified in which you can use the heater safely, without additional ventilation (*refer to Section J*). If a particular room is smaller than the specified space, always leave a window or door slightly ajar (± 2.5 cm). We also recommend doing this in highly insulated or draught-free rooms and/or at altitudes above 1,500 metres. Do not use your heater in cellars or other underground areas.

Be aware that the grid and the top plate become hot. If the appliance is covered there is a risk of fire. Due to high surface temperature, keep away from children.

ESPECIALLY FOR FRANCE: Your heater was designed to operate exclusively on fuel for liquid fuel-operated mobile heaters in accordance with the Decrees of 18-07-2002 and 25-06-2010. The use of other fuels is forbidden. Ask your dealer or check our website for the addresses of our retailers. The liquid fuel-operated mobile heater is intended as an extra heater, and not as a continuous source of heat.

ESPECIALLY FOR UNITED KINGDOM: Only use Class C1 paraffin fuel in accordance with BS2869; Part 2, or equivalent.

The user must comply with the following instructions for proper use:

DO NOT

- use the liquid fuel-operated mobile heater in caravans, boats, and vehicle cabins;
- use the liquid fuel-operated mobile heater in insufficiently ventilated rooms (consult the table of properties for the minimum dimensions of the room to be heated), underground rooms and / or at a height of over 1500 metres;
- modify the heater safety features.

The use of this type of heating in public rooms is subject to prior regulatory permission. Obtain proper information on this in advance.

THE RIGHT FUEL

Your heater has been designed for use with high-quality water-free pure paraffin oil. Only fuels of this kind will ensure clean and proper burning. Lower quality fuel may result in:

- increased possibility of malfunctioning
- incomplete burning
- reduced heater lifetime
- smoke and/or smells
- deposits on the grid or mantle

Using the right fuel is therefore essential for safe, efficient, and comfortable use of your heater.

Damage and/or malfunctions of the heater due to the use of other than high quality water-free pure paraffin oil is not covered by the warranty. Always refer to your local dealer for the right fuel for your heater.

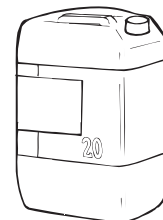

Only the use of the correct fuel will ensure safe, efficient, and comfortable use of your heater.



This transportation cap is packed separately in the box. Only this cap ensures trouble-free transportation of the heater after use. Store it well!

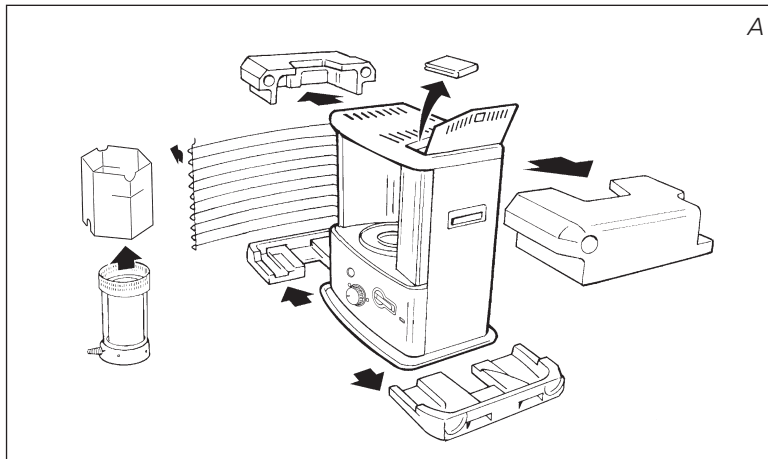

MANUAL

A INSTALLING THE HEATER

1 Carefully remove your heater from the box and check the contents.

In addition to the heater you also need to have:

- a manual fuel pump
- a transportation cap
- these directions for use

Keep the box and the packaging materials (Fig. A) for storage and/or transportation.

2 Remove the other packaging materials:

- Remove the packaging material from the grill **6**. Lift the grill from the slot (Fig. B) and pull it forward.
- Push the packing material on top of the combustion chamber **3** slightly down and remove it (Fig. C). Remove the packaging materials from under the combustion chamber as well (Fig. D).
- Put the combustion chamber back into its place. The combustion chamber is positioned correctly when it can be smoothly moved a little to the left and to the right by its handle **4** (Fig. E). Close the grill: Slightly lift it to reposition it in its slot.
- Open the lid of the removable tank **7** and remove the piece of cardboard.

3 Fill the removable tank as indicated in *Section B*.

4 The floor should be firm and completely level. Reposition the heater, when it is not level. Do not correct the situation by placing books or other goods under the heater.

5 Your heater is now ready for use.

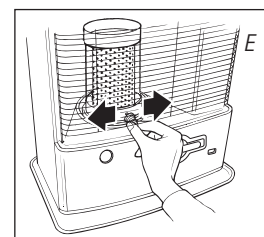
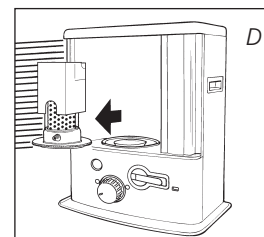
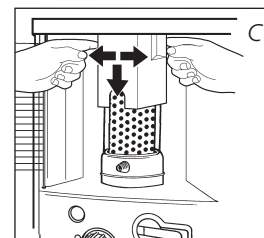
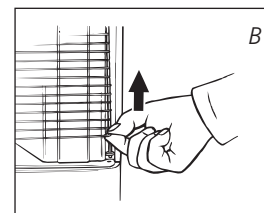

B FILLING FUEL

Fill the removable tank in a suitable place since there can always be some spillage. Follow the procedure below:

- 1 Make sure that the heater is switched off.
- 2 Open the upper lid 7 and lift the removable tank 8 out of the heater (Fig. G).
Note: Some drops may leak from the tank. Put down the removable tank (cap pointing upwards, handle on the floor) and screw off the fuel cap. (Fig. H).
- 3 Take the manual fuel pump and insert the smooth, most rigid tube into the jerrycan. Make sure that it is in a higher position than the removable tank (Fig. I). Insert the ribbed hose into the opening of the removable tank.
- 4 Lock the valve on top of the pump (turn clockwise).
- 5 Squeeze the pump a few times, until fuel starts flowing into the removable tank. As soon as this happens, there is no need to press any longer.
- 6 Check the fuel gauge of removable tank 9 while filling the tank (Fig. J). Stop filling by loosening the valve on top of the pump (turn anti-clock-wise), once the gauge indicates that the tank is full. Never overfill the tank, especially not when the fuel is very cold (fuel expands when it heats up).
- 7 Let the remaining fuel in the pump flow back into the jerrycan and carefully remove the pump. Carefully screw the fuel cap back on the tank (Fig. J1). Clean off any spilled fuel.
- 8 Check whether the fuel cap is straight and tightened properly. Reinstall the removable tank in the heater (cap down). Close the lid.
Be sure to tighten the fuel tank cap and confirm that there is no leakage of the fuel when the cap side is placed down. Then insert the removable fuel tank into the heater.

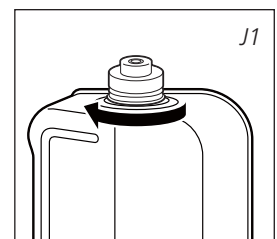
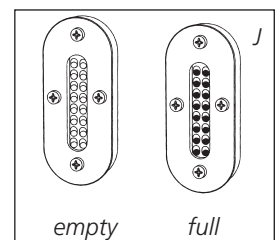
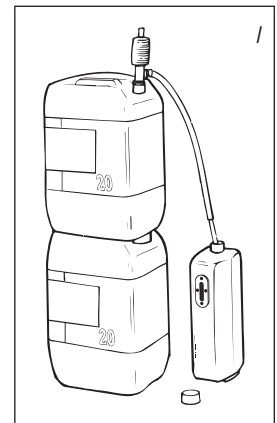
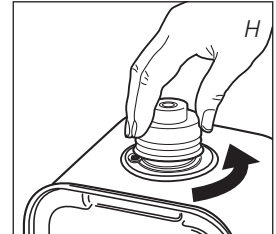
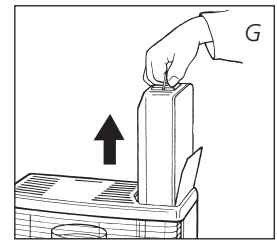

C IGNITING THE HEATER

A new heater may give off some smells for a short while, when it is used for the first time. You should therefore provide extra ventilation or ignite the heater outside the living room.

! When you use the heater for the first time, first put the filled removable tank into place, and then wait approximately 30 minutes before you ignite the heater. This allows the glass fibre wick to soak up the fuel. Follow the same procedure when you have completely burnt up all fuel from the tank, and after the glass fibre wick has been replaced.

Before igniting the heater, always check the fuel indicator 5 to see whether the removable tank needs filling up (Green=full, Red=empty).

Always ignite the heater with the knurled wick adjustment knob 2. Never use matches or a cigarette lighter.

Follow the procedure below:

GB

6



- 1** Turn the knurled wick adjustment knob **2** clockwise to its stop (Fig. K). If you apply more pressure you may turn it slightly further; however, it will automatically return to the start position. When you have set the wick to its highest position, this action will automatically activate the safety device.

Pull out the handle of "dynamo" until the handle is locked without fail. (Fig. L1)

Turn it to the direction of either right or left (Fig. L2,M). You will hear discharging sound for ignition. The heater may not be ignited if the rotation speed is slow even you hear the discharging sound. Make sure to turn it around 1.5~2 times per second.

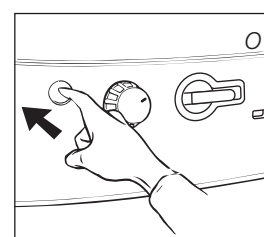
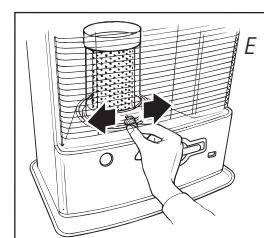
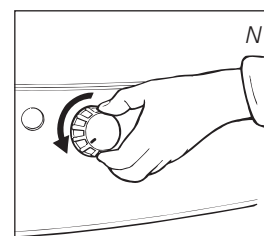
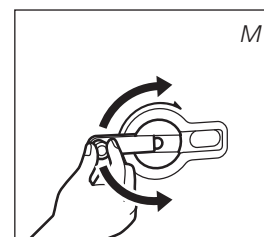
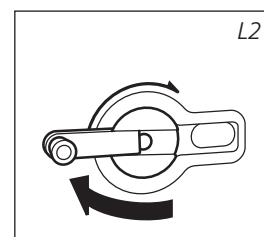
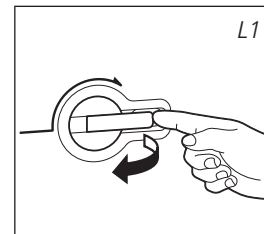
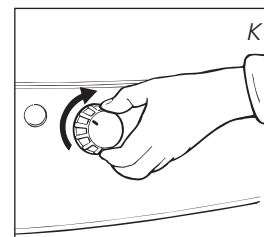

! If the heater has been used only a few times and the wick adjustment knob is not locked, first turn the wick adjustment knob (Fig. N) completely left, before putting the wick in the highest position for ignition (Section C).

! After having ignited the heater, always check whether the combustion chamber **3** is level, by sliding it slightly to the left and the right by combustion chamber handle **4** (Fig. E). This should be a smooth movement. If the combustion chamber is not level, this will cause smoke and soot to develop.

D BURNING OF THE HEATER

After you have ignited the heater, it will take 10 to 15 minutes before you can check whether the heater is burning well. Too high a flame may cause smoke and soot, whereas too low a flame causes smells. The page opposite the folding page shows the minimum and maximum permissible burning heights of the flame (Fig. R).

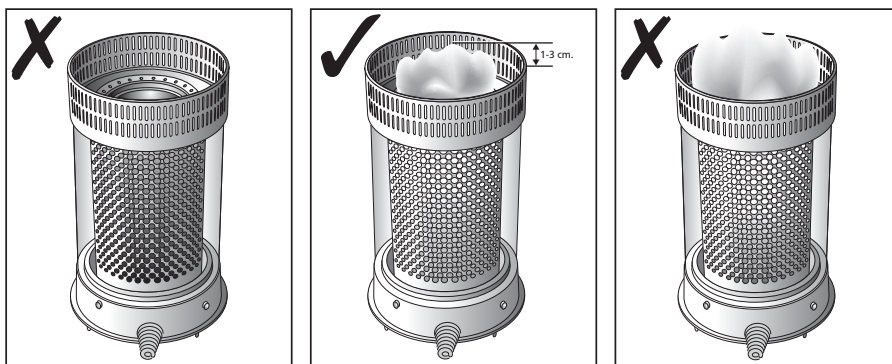

! If the flame remains low after the adjustment, the wick height must be adjusted (refer to Section G).

Burning that is too low may be caused by:

- insufficient fuel (fill the tank)
- poor fuel quality (contact your dealer)
- insufficient ventilation (put window or door ajar)
- wastage of the wick (contact your dealer or replace the wick, refer to section L)

E SWITCHING OFF THE HEATER

Push the OFF-button **1**. The flame will extinguish after a little while (Fig. O).

F MALFUNCTION, CAUSES AND SOLUTIONS

If any malfunctioning cannot be solved from the directions below, please contact your dealer.

THE HEATER DOES NOT IGNITE

- You have run out of fuel from the tank or the wick has been replaced.
After having refilled and replaced the removable tank, wait for 30 minutes before igniting the heater.

IRREGULAR FLAME AND/OR SOOT AND/OR SMELLS

- The combustion chamber ③ has not been positioned correctly.
Use the combustion chamber handle ④ to put it level, until you can easily slide it slightly to the left and to the right and the chamber is level.
- You are using fuel which is past its 'use by' date.
Start every heating season with fresh fuel.
- You are using the incorrect type of fuel.
Refer to THE RIGHT FUEL (See Section 'What you need to know in advance').
- Dust has gathered in the lower part of the heater.
Contact your dealer.
- The wick height is not correct.
Contact your dealer.

THE HEATER SLOWLY EXTINGUISHES

- The removable tank is empty.
See Section B.
- The lower reservoir is contaminated by water.
Contact your dealer.
- The wick has hardened on the upper side.
Burn the heater until all fuel is used (Section G). Use the right fuel.
- You are using fuel which is past its 'use by' date.
Start every heating season with fresh fuel.

THE HEATER REMAINS BURNING LOW

- Wick position too low.
Contact your dealer.
- Before you refilled the tank, the heater had burnt up almost all the fuel.
After having refilled and replaced the removable tank, wait for 30 minutes before igniting the heater.
- You are using the incorrect type of fuel.
Refer to THE RIGHT FUEL (See Section 'What you need to know in advance').
- The room is insufficiently ventilated.
Leave a window or a door wide open for a while.

THE HEATER IS BURNING TOO HIGH

- You are using an incorrect, too volatile type of fuel.
Refer to THE RIGHT FUEL (See Section 'What you need to know in advance').
- Wick position too high.
Contact your dealer.

G MAINTENANCE

Your heater needs hardly any maintenance. It is, however, important that you remove dust and stains in time with a damp cloth, because otherwise these may cause stains that are hard to remove. Under normal conditions, only two components are subject to wear:

1. THE WICK

To extend the glass fibre wick life, you must occasionally let the heater burn until the tank is completely emptied and the heater extinguishes by itself. Do this when you notice that the flame is weakening. The burn-out will cause some smells, so it is recommended that you take the heater outside of the living room.



2. Electrodes

When the electrodes gets dirty by carbon or tar, clean the electrodes following "the cleaning procedure of electrodes". If the electrodes digs into the wick, it may cause the ignition failure. Then fix the position of the electrodes following "the fixing position procedure of the wick". Be sure not to spill the water on the electrodes.

! Do not remove any heater components yourself. Always contact your dealer for repairs.

! Let the heater cool down first, before you start any maintenance or service work.

! The electrodes arise high voltage during ignition. Do not turn the handle of "dynamo" and not touch ignition plug during maintenance.



H STORAGE (END OF THE HEATING SEASON)

We recommend that you burn up all the fuel in the fuel tank at the end of the heating season and store the heater properly. Follow the procedure on the next page:

- 1 Ignite the heater outside the living room and let it burn until all fuel is used.
- 2 Let the heater cool down.
- 3 Clean the heater with a damp cloth and then dry it with a dry cloth.
- 4 Store the heater in a dust-free place, if possible in its original packaging.
Unused fuel cannot be used for the next heating season. If there is still some fuel left, do not throw it away, but dispose of it in accordance with the local regulations for the disposal of domestic chemical waste. Always start the new heating season with fresh fuel. When you start re-using the heater, follow the instructions again (*starting from Section A and as specified*).

I TRANSPORTATION

Take the following measures to avoid fuel leakage during the transportation of the heater:

- 1 Let the heater cool down.
- 2 Remove the removable tank **8** from the heater. Store the removable tank outside the heater.
- 3 Place the transportation cap into the position (Fig. P).
Press it tight.
- 4 Always move the heater in an upright position.

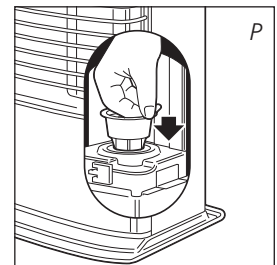

Transportation cap

J SPECIFICATIONS

Ignition	electrical	Dimensions (mm)	width	428
Fuel	paraffin	(including base plate)	depth	295
Capacity (kW)*	2.40		height	453
Suitable space (m ³)**	40-85	Accessories:	transportation cap	
			manual fuel pump	
Fuel consumption (l/hr)*	0.250			
Fuel consumption (g/hr)*	200			
Burning time per tank (hr)*	16	Wick type	F	
Capacity removable tank (litres)	4.0			
Weight (kg)	7.5			

* At maximum setting

** Specified values are indicative

K WARRANTY PROVISIONS

Your heater comes with a 48 months warranty starting on the date of purchase. Within this period all defects in material or workmanship will be repaired without any charge. The following provisions shall apply regarding this warranty:

- 1 We expressly dismiss all other claims for damages, including consequential damages.
- 2 Any repairs or replacements of components within the term of warranty will not result in an extension of the term of warranty.
- 3 The warranty will no longer apply, when the heater has been modified, non-original parts have been used, or when it is repaired by third parties.
- 4 The warranty will not apply to parts that are subject to normal wear, such as the ignition coil, the wick and the manual fuel pump.
- 5 The warranty will only apply, when you present the original, dated proof of purchase, provided no changes have been made to it.
- 6 The warranty will not apply to damages caused by actions not in compliance with the Directions for Use, neglect, and the use of an incorrect type of fuel, or fuel past its use-by date. The use of incorrect fuel can even be dangerous*.
- 7 Transportation costs and the risks involved during the transportation of the heater or heater components will always be the responsibility of the purchaser.



In order to avoid unnecessary costs, we recommend that you always read the 'Directions for Use' carefully first. In case they offer no solution, please take the heater to your dealer for repair.

* Highly inflammable substances may induce uncontrollable burning, causing flames to break out. Should this happen, never try to move the heater, but always switch off the heater immediately (*refer to Section E*). In cases of emergency you may use a fire extinguisher, but only a type B extinguisher: a carbon dioxide or powder extinguisher.

14 TIPS FOR SAFE USE

- 1 Make sure that children are always aware of the presence of a burning heater.
- 2 Do not move the heater when it is burning or still hot. Do not refill nor service the heater when it is burning or still hot.
- 3 Position the front of the heater at a minimum distance of 1.5 metres from walls, curtains, and furniture.
- 4 Do not use the heater in dusty rooms or in very draughty places. In both cases you will not have optimum burning.
- 5 Switch off the heater, before you go to sleep.
- 6 Store and move fuel only in suitable tanks and jerrycans.
- 7 Make sure that the fuel is not exposed to heat or extreme temperature changes. Always store the fuel in a cool, dry and dark place (sunlight will affect the quality).
- 8 Never use the heater in places where harmful gasses or fumes may be present (e.g. exhaust gasses or paint fumes).
- 9 The top plate of the heater becomes hot. Do not cover the heater (there is a risk of fire). Avoid any contact with the top plate and grille.
- 10 Always make sure that there is sufficient ventilation.
- 11 This appliance is not intended for use by persons (including children) with reduced physical, sensory or mental capabilities, or lack of experience and knowledge, unless they have been given supervision or instruction concerning use of the appliance by a person responsible for their safety.
- 12 This appliance can be used by children aged from 8 years and above and persons with reduced physical, sensory or mental capabilities or lack of experience and knowledge if they have been given supervision or instruction concerning use of the appliance in a safe way and understand the hazards involved.
- 13 Children shall not play with the appliance.
- 14 Cleaning and user maintenance shall not be made by children without supervision.

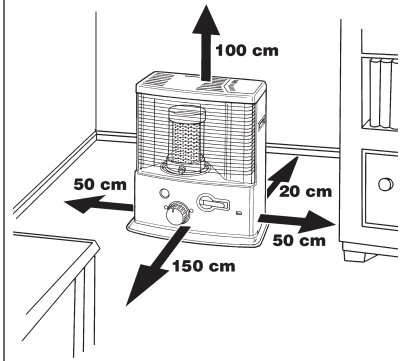

REPLACEMENT OF THE WICK

L ENSURE THAT THE HEATER IS OFF AND COMPLETELY COOL BEFORE STARTING TO REPLACE THE WICK.

- 1 Open the lid and remove the removable tank.
- 2 Open the front grill. Remove the combustion chamber from the heater. Close the grill.
- 3 Pull the knurled wick adjustment knob off the heater. Pull out the handle of "dynamo", and remove a screw at the center by holding the handle. Then, pull out the handle.
- 4 Unscrew the three cabinet screws on the back and sides of the heater. Pull the cabinet forward slightly, and then remove it from the base plate.
- 5 Unscrew the four wing nuts from the wick holder.
- 6 Lift the wick holder chassis up until the wick is visible. Place the burner bed next to the heater. (Ensure that the wiring does not become disconnected).
- 7 Remove the screw on the stem holding the bracket and remove the bracket.
- 8 Turn right the stem to the end and remove the wick sleeve (with wick).
- 9 Turn the wick sleeve counterclockwise and lift the wick sleeve up. Remove it from the primary air tube.
- 10 Squeeze the wick to loosen the three wick pins and remove the wick from the wick sleeve. Ensure that you are wearing gloves and that you have a container in which to put the old wick.

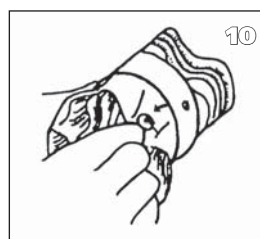
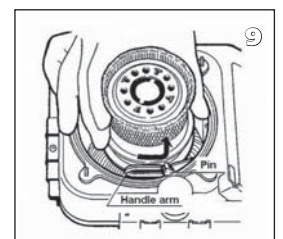
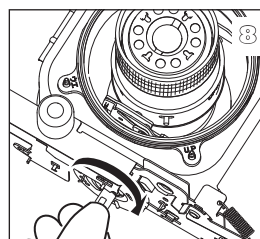
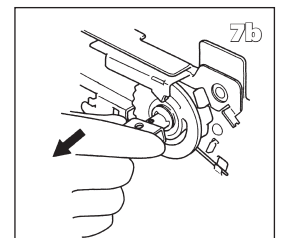
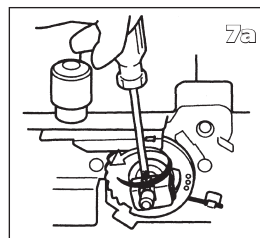
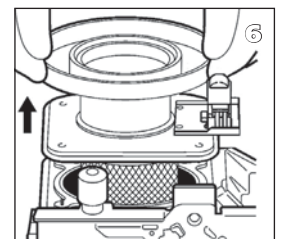
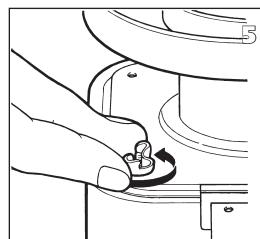
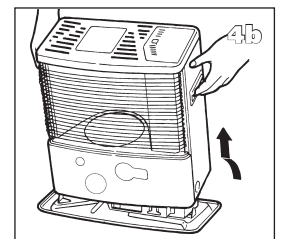
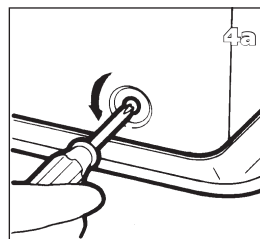
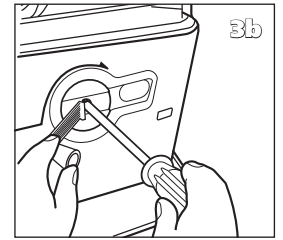
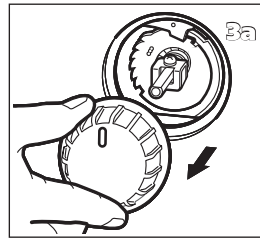
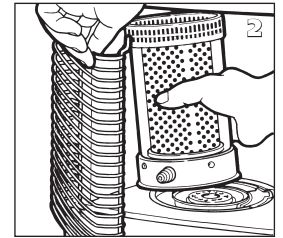
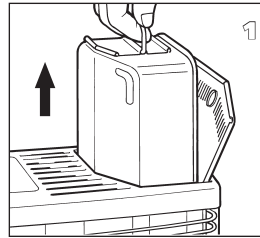

- 11 Install the wick to the wick sleeve according to the allowed direction engraved on the wick sleeve.
- 12 Install the wick sleeve (with wick) to the primary air tube. And then turn the wick sleeve clockwise to set in the handle arm.
- 13 Install the bracket. Then tighten the screw which is holding the stem.
- 14 Put the wick holder chassis back into position.
- 15 Screw the four wing nuts hand tight.
- 16 Place the knurled wick adjustment knob on the wick mechanism. Turn the knob as far to the right as possible. Press the tip-over switch. Check that the wick can be lowered completely. Repeat this check a number of times. If the wick cannot be lowered completely it has not been placed correctly. If this is the case, repeat the procedure from No. 12. Pull the knurled wick adjustment knob off the heater.
- 17 Put the cabinet back into position and tighten the three screws. Tighten the screw to fix the handle of "dynamo" by holding the handle. Put the knurled wick adjustment knob back into position. Now put the combustion chamber back into position. Check that it is level by sliding it slightly to the left and the right by its handle. Close the grill.
- 18 Put the filled removable tank into position. Wait 30 minutes after replacing the tank before using the heater.

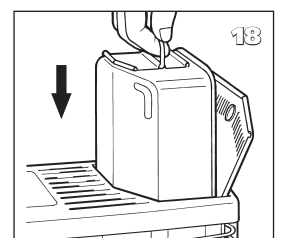
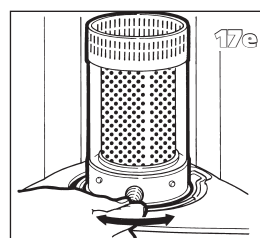
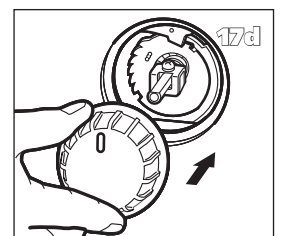
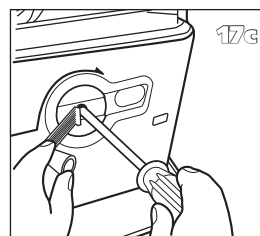
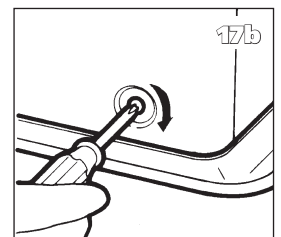
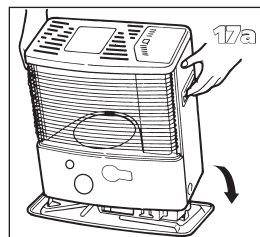
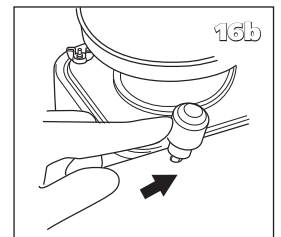
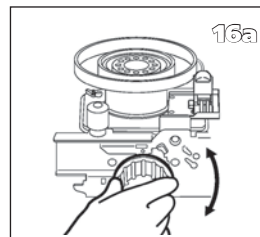
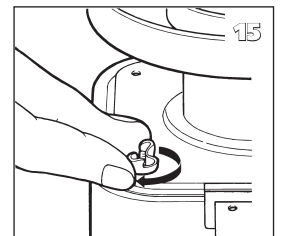
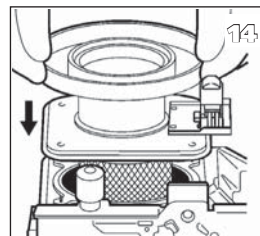
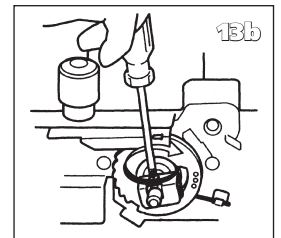
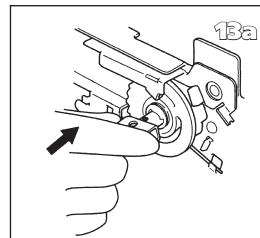
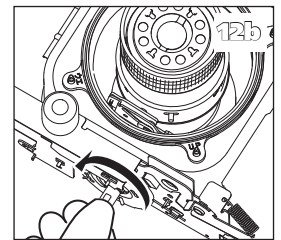
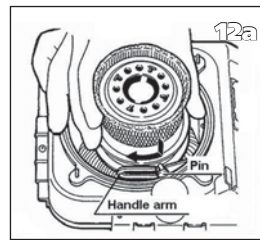
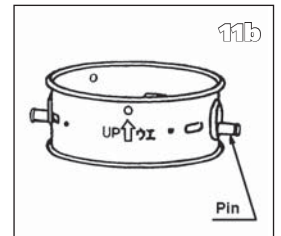
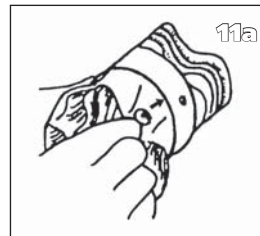

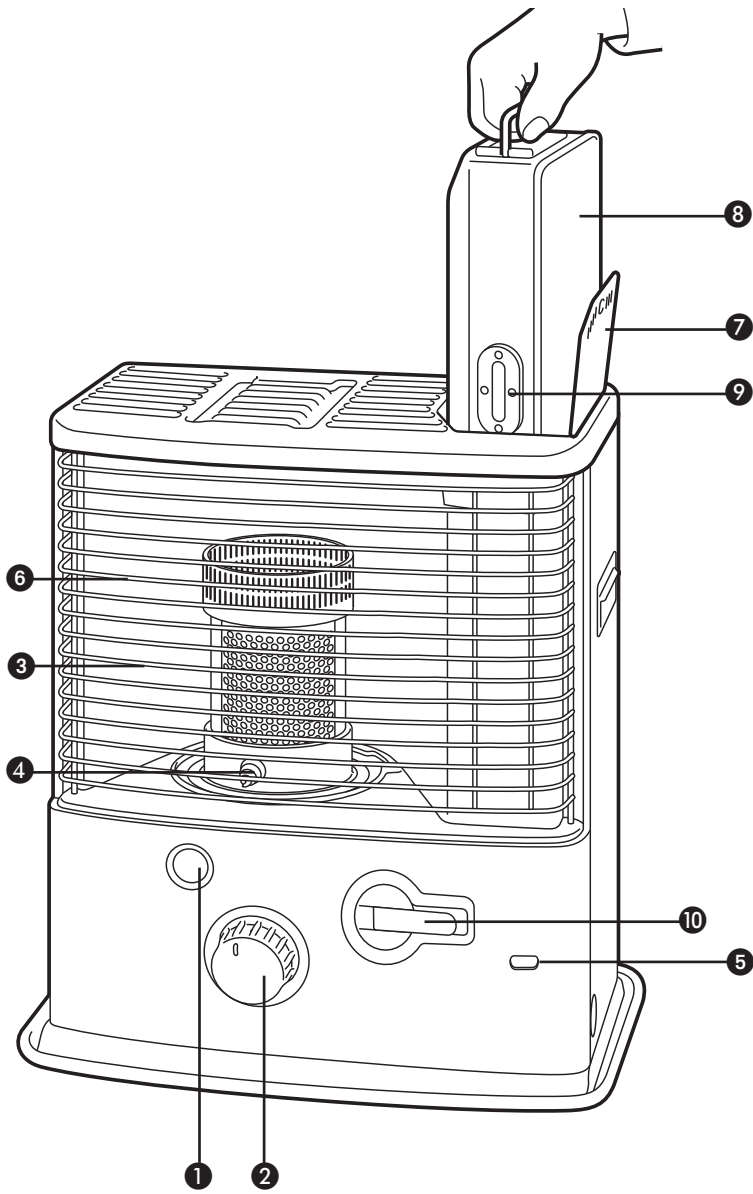

MAIN COMPONENTS

- ① OFF - button
- ② Knurled wick adjustment knob
- ③ Combustion chamber
- ④ Combustion chamber handle
- ⑤ Fuel indicator
- ⑥ Grill
- ⑦ Lid for removable tank
- ⑧ Removable tank
- ⑨ Fuel gauge of removable tank
- ⑩ Handle of dynamo

zibro®

made by **TOYOTOMI**

Distributed in Europe by TOYOTOMI EUROPE SALES B.V.

Should you require further information or should particular problems occur that are not dealt with in this operating manual, please visit our website www.toyotomi.eu or contact our Sales Support (you find its phone number on www.toyotomi.eu)

Falls Sie weitere Informationen wünschen, oder sollten besondere Probleme auftreten, die in dieser Bedienungsanleitung nicht ausführlich genug behandelt werden, besuchen Sie bitte unsere Website (www.toyotomi.eu), oder fordern Sie die benötigte Auskunft von unserem Kundendienst an (Telefonnummer auf www.toyotomi.eu)

Vous souhaitez obtenir des informations supplémentaires ou si vous rencontrez un problème, rendez-vous sur notre site Web (www.toyotomi.eu) ou contactez notre service client (vous trouverez l'adresse et le numéro de téléphone sur www.toyotomi.eu)

Wenst u nadere informatie, of indien er bijzondere problemen optreden die in deze gebruiksaanwijzing niet behandeld zijn, bezoekt u dan onze website www.toyotomi.eu of vraag de benodigde informatie op bij de afdeling Sales Support (adres en telefoonnummer op www.toyotomi.eu)

Si necesitara más información o surgiera algún problema concreto que no abarque este manual operativo, visítenos en www.toyotomi.eu o contacte con nuestro equipo de asistencia postventa (encontrará el número de teléfono en www.toyotomi.eu).

In caso aveste bisogno di ulteriori informazioni o riscontrate particolari problemi che non sono presi in considerazione nel presente manuale, vi invitiamo a visitare il nostro sito www.toyotomi.eu o contattare la nostra assistenza (il cui numero di telefono é indicato nel nostro sito www.toyotomi.eu)

Hvis du ønsker yderligere information eller, hvis der opstår problemer, som ikke behandles i brugsanvisningen, bedes du besøge vores webside www.toyotomi.eu eller kontakt afdelingen Sales Support (adresse og telefonnummer på www.toyotomi.eu).

Om du ønsker mer informasjon, eller om et problem har dukket opp som ikke er dekket i disse instruksjonene, besøk oss gjerne på www.toyotomi.eu eller be om den nødvendige informasjonen fra avdelingen for brukerstøtte (adresse og telefonnummer kan finnes på www.toyotomi.eu).

Om du önskar mer information, eller om några problem uppstår som inte har berörts i dessa instruktioner, besök då vår hemsida www.toyotomi.eu eller begär den nödvändiga informationen från Säljsupport avdelningen (adress och telefonnummer finns på www.toyotomi.eu).

Jos haluat lisätietoja tai kohtaat ongelmia, joita ei käsitellä näissä ohjeissa, verkkosivustolla osoitteessa www.toyotomi.eu tai pyydä tarvittavat tiedot myynnin tukiosastolta (osoite ja puhelinnumero löytyy sivustolta www.toyotomi.eu).



Kerosun®, Toyostove®, Toyoset®, Toyotomi® and Zibro® for the use of paraffin heaters are all registered trademarks of TOYOTOMI Co., Ltd. - Japan.

Zibro® brand paraffin heaters are made in JAPAN and imported by Toyotomi Europe Sales b.v.