

Transform your tablet into a powerful sales tool.



The CT300 is a complete tablet solution that turns a security challenge into a sales opportunity. It features 3-axis viewing, optional mobile POS device integration, and USB 2.0 ports that enable transactions wherever and whenever customers are ready. Auditing and unlimited mobility are possible with software control and rapid tablet undocking

technology. CT300's tough and durable security stand makes it possible for tablets to be left unattended as self-service kiosks. The stand provides power and security to integrated tablets and mobile POS devices, and the ergonomic security frames accommodate 8" to 12" tablets.



FEATURES AND BENEFITS

- 1 Rapid tablet undocking using InVue IR key or software control
- 2 3-axis viewing and optional mobile POS device integration
- 3 Stand available with two USB 2.0 connections to support peripherals and data connectivity
- 4 Mounting versatility with bolt, adhesive, or optional free standing base
- 5 Stands and frames are compatible with 8", 10" and 12" Apple, Android and Windows tablets
- 6 Supports integration with mobile POS chip and pin readers
- 7 Stand has a built-in alarm with battery backup that can be configured audible or silent and can send out alarm notification
- 8 Optional Gang Charger with security function capability allows up to 10 devices within CT300 frames to charge at once, five tablets and five integrated mobile point of sale devices
- 9 Ergonomic frames are available to support a single tablet or a tablet with mobile POS device, and all frames come standard with a hand strap, swivel capability, and the option to add an available shoulder strap (not shown)
- 10 Unique frame hinge allows mobile POS device to be forward facing, rear facing, secured in the frame, or removable by an associate



IR ECOSYSTEM™

CT300 is part of the exclusive InVue IR Ecosystem™, a storewide single key solution that improves customer service, increases sales and provides high theft protection.



- Handheld Electronics
- Electronic Accessories
- Secure Fixtures
- Package Protection
- Locked Cabinets
- Commercial Solutions



SPECIFICATIONS

CT300 Stand with USB (CTG2E001-B/W)

CT300 Stand without USB (CTG2S001-B/W):

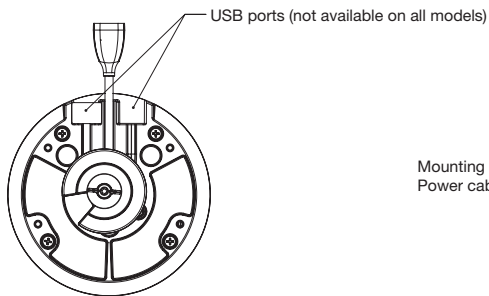
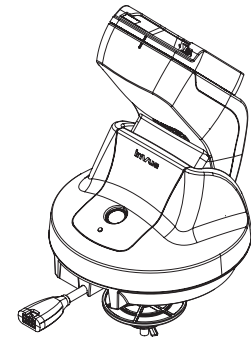
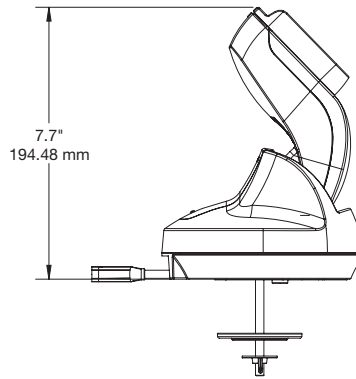
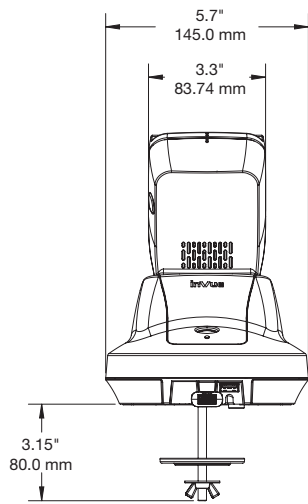

Mounting hole required: 1" (25.4 mm)
Power cable length: 39.37" (1.5 m) from exit of stand



SPECIFICATIONS

CT300 for HP Pro 608 BLE Frame, Verifone USB E355 Support (CTG2F004-B/W):

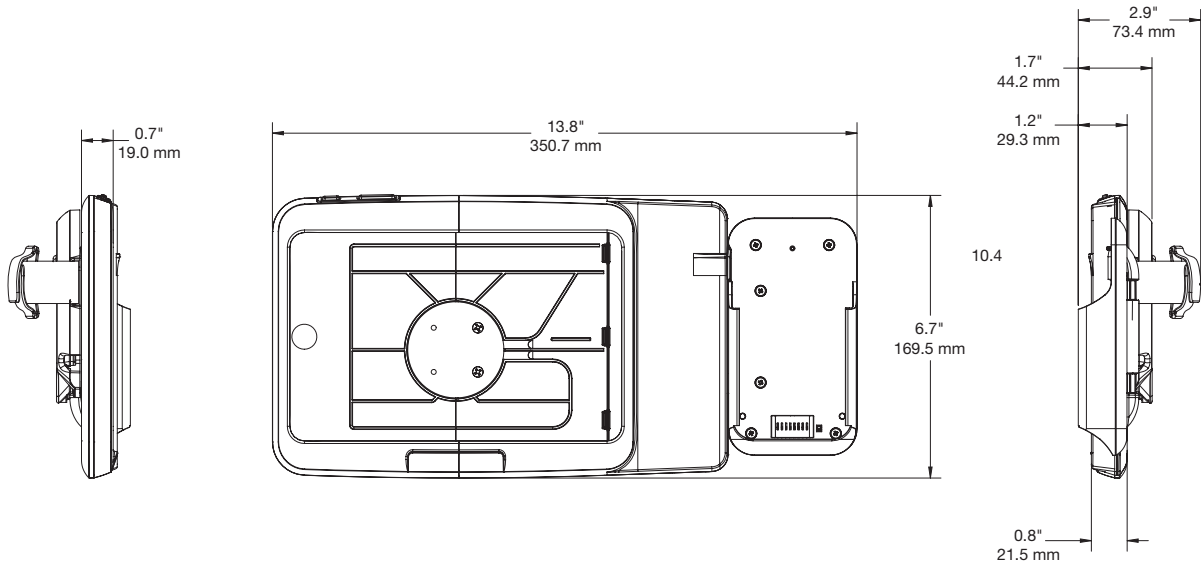

CT300 for iPad Air 2 BLE Frame, Verifone USB E355 Support (CTG2F005-B/W):

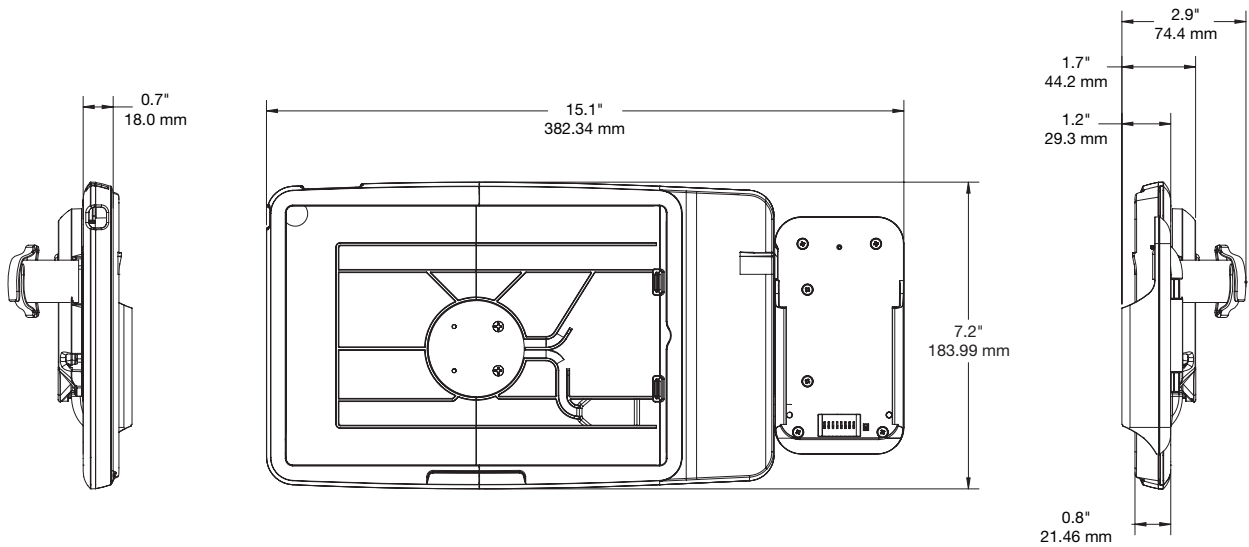

SPECIFICATIONS

CT300 for Lenovo TP10 Frame, Verifone USB E355 Support (CTG2F006-B/W):

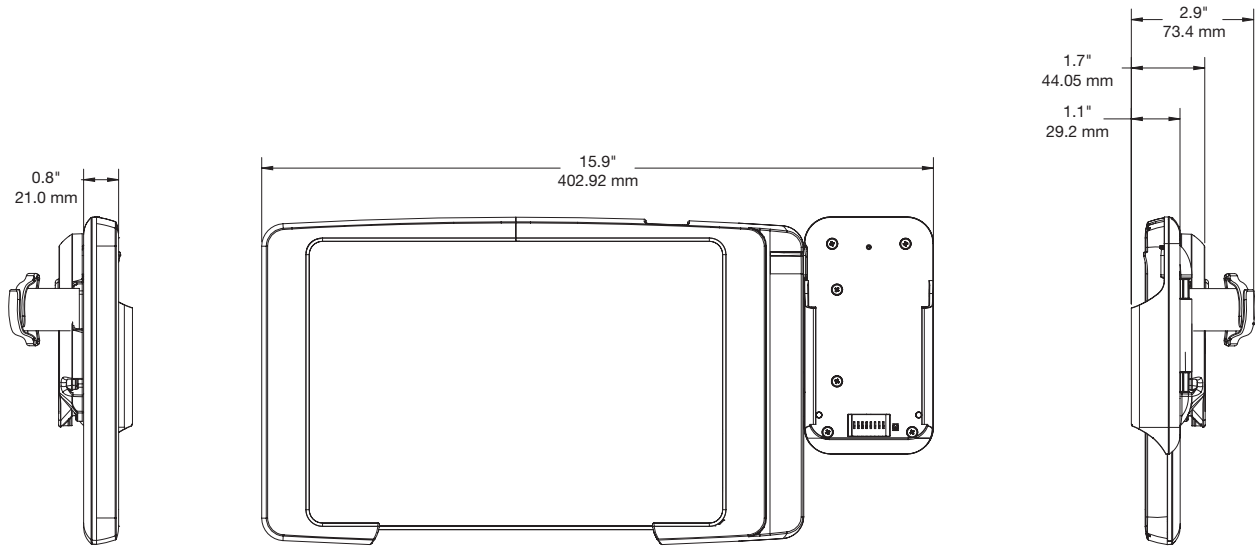

CT300 for iPad Air 2 Frame, Charge Only (CTGF007-B/W):

CT300 for iPad Air 2 BLE Frame (CTG2F001-B/W):

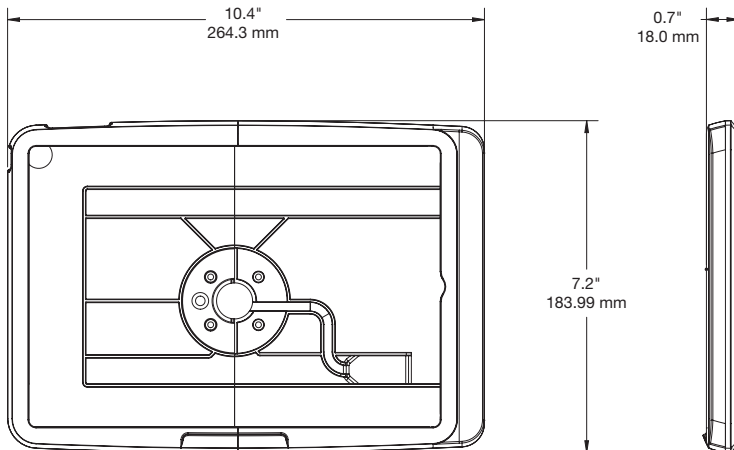

SPECIFICATIONS

CT300 for HP Pro 608 Frame, Charge Only (CTGF009-B/W):

CT300 for HP Pro 608 BLE Frame (CTG2F003-B/W):

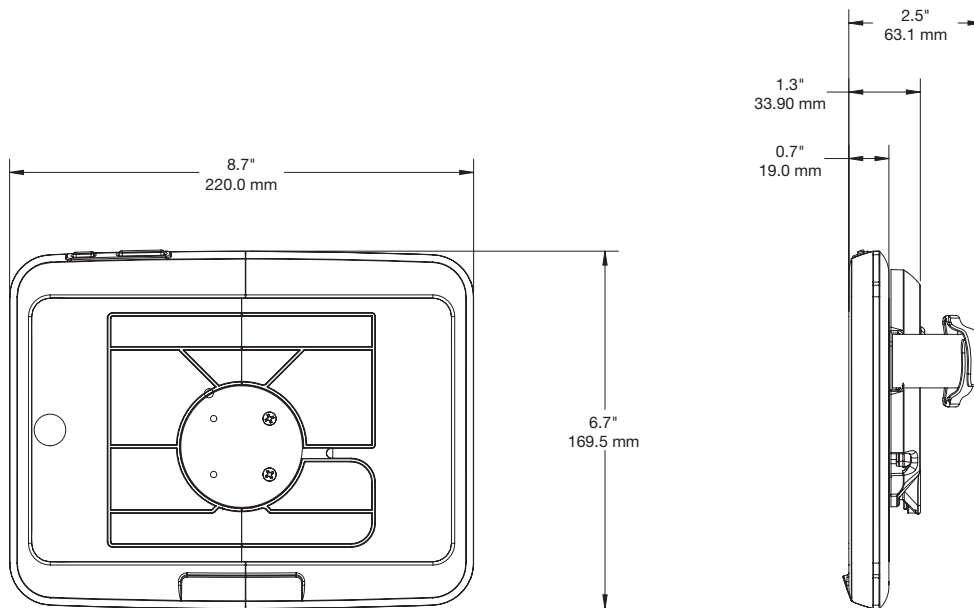

CT300 iPad Air 2 BLE Frame, Ingenico iSMP Support (CTG2F015- B/W):

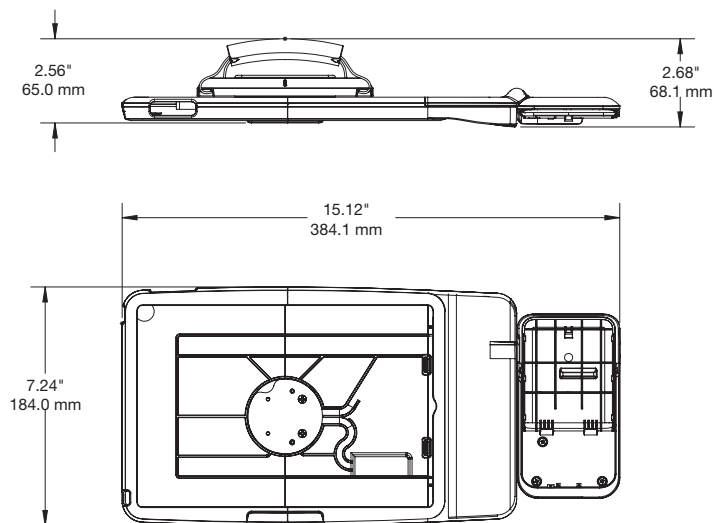

SPECIFICATIONS

CT300 Gang Charger, 5 Frame Capacity (CTG2GC):

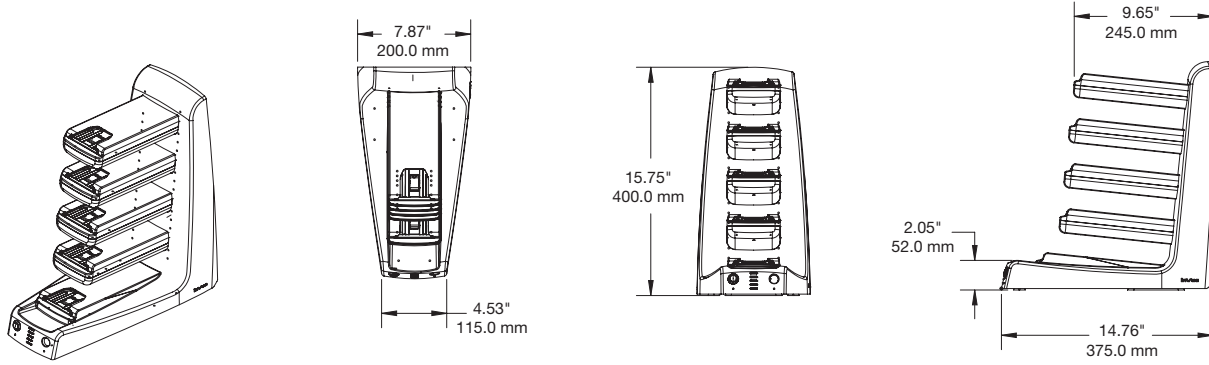

PRODUCT ORDERING

ORDER CODE	DESCRIPTION	CARTON QTY.
CTG2E001-B CTG2E001-W	CT300 Stand with USB - Black CT300 Stand with USB - White	1
CTG2S001-B CTG2S001-W	CT300 Stand, no USB - Black CT300 Stand, no USB - White	1
CTG2F001-B CTG2F001-W	CT300 iPad Air 2 BLE Frame - Black CT300 iPad Air 2 BLE Frame - White	1
CTG2F003-B CTG2F003-W	CT300 HP Pro 608 BLE Frame - Black CT300 HP Pro 608 BLE Frame - White	1
CTG2F004-B CTG2F004-W	CT300 HP Pro 608 BLE Frame, Verifone USB e355 Support - Black CT300 HP Pro 608 BLE Frame, Verifone USB e355 Support - White	1
CTG2F005-B CTG2F005-W	CT300 iPad Air 2 BLE Frame, Verifone USB e355 Support - Black CT300 iPad Air 2 BLE Frame, Verifone USB e355 Support - White	1
CTG2F006-B CTG2F006-W	CT300 Lenovo TP10 2nd Gen BLE frame, Verifone USB e355 Support - Black CT300 Lenovo TP10 2nd Gen BLE frame, Verifone USB e355 Support - White	1
CTG2F007-B CTG2F007-W	CT300 iPad Air 2 Frame, Charge Only - Black CT300 iPad Air 2 Frame, Charge Only - White	1
CTG2F009-B CTG2F009-W	CT300 HP Pro 608 Frame, Charge Only - Black CT300 HP Pro 608 Frame, Charge Only - White	1
CTG2F015-B CTG2F015-W	CT300 iPad Air2 BLE Frame, Ingenico iSMP Support - Black CT300 iPad Air2 BLE Frame, Ingenico iSMP Support - White	1
CTG2EP001	CT300 USB Right Angle Adapter, 2 Pack	1
CTG2EP002	CT300 USB Port Cover, 4 Pack	1
CTG2GC	CT300 Gang Charger - Black	1
CTG2P001	CT300 Desktop Freestanding Plate	1
CTG2P002	CT300 Stand Adhesive Removal Tool	1
CTG2P003-B	CT300 Frame Shoulder Strap - Black	1
CTG2P004	CT300 Frame Hand Strap - Black	1
CTG2P005	CT300 iPad Frame Power Connector	1
CTG2P006	CT300 Cable Adapter Alarm Signal Out	1
CTG2P007	CT300 Frame Replacement Screws, 6 Pack	1
CTG2P008-B	CT300 Stand Portrait to Landscape Button Blocker, 5 Pack - Black	1
CTG2P009-B	CT300 iPad Air2 Frame Power, Home, Audio, Volume Blockers, Black - 5 of each Blocker (20 total)	1
CTG2P009-W	iPad Air2 Frame Power, Home, Audio, Volume Blockers - 5 of each Blocker (20 total)	1
CTG2P010	CT300 Frame Reader Cradle Replacement Screws, 5 Pack	1
CTG2P011	CT300 Lenovo TP10 Frame Replacement USB and Power Connectors, 2 of each (4 total)	1



PRODUCT ORDERING

ORDER CODE	DESCRIPTION	CARTON QTY.
ADH2099	CT300 Stand Adhesive Kit, 8 Pack	1
ADH2102	CT300 Stand Replacement Adhesive, 13mm Diameter, 12 Pack	1
CTG2PS01-US	CT300 Stand Power Supply, 5V/5A & 12V/3A Out - US	1
CTG2PS01-AUS	CT300 Stand Power Supply, 5V/5A & 12V/3A Out - AUS	
CTG2PS01-EU	CT300 Stand Power Supply, 5V/5A & 12V/3A Out - EU	
CTG2PS01-JPN	CT300 Stand Power Supply, 5V/5A & 12V/3A Out - JPN	
CTG2PS01-UK	CT300 Stand Power Supply, 5V/5A & 12V/3A Out - UK	
PS24V65-US	Gang Charger Power Supply - US	1
PS24V65-AUS	Gang Charger Power Supply - AUS	
PS24V65-EU	Gang Charger Power Supply - EU	
PS24V65-JPN	Gang Charger Power Supply - JPN	
PS24V65-UK	Gang Charger Power Supply - UK	



ENVIRONMENTAL SPECIFICATIONS

Stand:

Operating Temperature: 0°C 0% RH to 40°C and 80%RH

Shipping and Storage Specifications: -20°C and 0%RH and 72 hours at 70°C and 85%RH

Gang Charger:

Operating Temperature: 0 Degrees C to 40 Degrees C; 0-85% RH non-condensing

Storage Temperature: -20 Degrees C to 70 Degrees C; 0-85% RH

Surface Touch Temperature: 50 Degrees C metal; 60 Degrees C plastic

POWER SUPPLY SPECIFICATIONS

CT300 Stand:

AC/DC Adaptor (Power Supply):

› *Input:* 100-240V @ 50-60Hz, 4A

› *Output:* 5VDC @ 5A; 12VDC @ 3A

Tablet Charging Power:

5V @ 3A

12V @ 3A

Mobile Device Charging Power:

5V @ 1A

Two USB 2.0 Type A Ports capable of delivering up to 500mA each

Agency Certifications: CE, FCC

Silent Alarm Signal Out:

Voltage Range: 60V Maximum

Current Range: 100mA Maximum

Contact Type: Normally Open (1-Form-A) Contact

Contact Resistance: 8 Ohm Maximum

Connection Type: Terminal Block; 16-30 AWG Solid Wire; 16-30 AWG Stranded Wire; Small Flat Screwdriver

Operation: No Alarm-Contacts Open; When in Alarm Mode-Contacts Closed (shorted together)

Tablet Frames Currently Available:

HP Pro Tab 608

iPad Air2

Lenovo 2nd Generation TP10 (InVue frame also compatible with Lenovo TP10 Pro Dock. InVue frame supports Lenovo tablet "Take Home Mode", so tablet may be quickly and easily removed from frame without tools.)

Mobile Payment Devices Currently Integrated:

Verifone E355, Ingencio iSMP

invue.com

©2016 InVue Security Products. No endorsement of InVue products has been made by any of the manufacturers of the products shown. Product is sold pursuant to InVue's warranty which can be found at www.invue.com/warranty.

THE AMERICAS 704.752.6513 • 888.55.INVUE

EUROPE, MIDDLE EAST & AFRICA +31.23.8900150

ASIA PACIFIC +852.3127.6811

